



INVERTER

FR-F700

INSTRUCTION MANUAL (BASIC)

FR-F720-00046 to 04750-NA

FR-F740-00023 to 12120-NA

Thank you for choosing this Mitsubishi Inverter.
 This Instruction Manual (basic) is intended for users who "just want to run the inverter".
 If you are going to utilize functions and performance, refer to the *Instruction Manual (applied)* [IB-0600217ENG].
 Please read the provided CD-ROM for the instruction manual (applied).

CONTENTS

1	PRODUCT CHECKING AND PARTS IDENTIFICATION	1
2	INSTALLATION AND WIRING	2
2.1	Peripheral devices	3
2.2	Method of removal and reinstallation of the front cover	5
2.3	Installation of the inverter and instructions	7
2.4	Wiring	9
2.5	Power-off and magnetic contactor (MC).....	26
2.6	Precautions for use of the inverter.....	27
3	DRIVE THE MOTOR	28
3.1	Step of operation	28
3.2	Operation panel (FR-DU07)	29
3.3	Overheat protection of the motor by the inverter (Pr.9).....	33
3.4	When the rated motor frequency is 50Hz (Pr.3).....	34
3.5	Operation by the start command from the operation panel (PU operation mode).....	35
3.6	Operation by the start command of the terminal block (external operation).....	43
4	ADJUSTMENT	51
4.1	Simple mode parameter list.....	51
4.2	Increase the starting torque (Pr. 0).....	53
4.3	Limit the maximum and minimum output frequency (Pr.1, Pr.2).....	54
4.4	Change acceleration and deceleration time (Pr.7, Pr.8).....	55
4.5	Energy saving operation (Pr. 60).....	56
4.6	Selection of the operation command and frequency command locations (Pr.79).....	58
4.7	Parameter clear	59
4.8	All parameter clear.....	60
4.9	Parameter copy	61
4.10	Parameter verification.....	62
5	TROUBLESHOOTING	63
5.1	List of alarm display	63
5.2	Causes and corrective actions	64
5.3	Reset method of protective function.....	75
5.4	Correspondences between digital and actual characters	75
5.5	Check and clear of the alarm history.....	76
5.6	Check first when you have troubles.	78
6	PRECAUTIONS FOR MAINTENANCE AND INSPECTION	80
6.1	Inspection Item	80
6.2	Measurement of main circuit voltages, currents and powers.....	90
7	SPECIFICATIONS	92
7.1	Rating.....	92
7.2	Common specifications	94
7.3	Outline dimension drawings	96



This instruction manual (basic) provides handling information and precautions for use of the equipment.
Please forward this instruction manual (basic) to the end user.

This section is specifically about safety matters

Do not attempt to install, operate, maintain or inspect the inverter until you have read through this instruction manual (basic) and appended documents carefully and can use the equipment correctly. Do not use the inverter until you have a full knowledge of the equipment, safety information and instructions. In this instruction manual (basic), the safety instruction levels are classified into "WARNING" and "CAUTION".

- WARNING** Assumes that incorrect handling may cause hazardous conditions, resulting in death or severe injury.
- CAUTION** Assumes that incorrect handling may cause hazardous conditions, resulting in medium or slight injury, or may cause physical damage only.

Note that even the **CAUTION** level may lead to a serious consequence according to conditions. Please follow strictly the instructions of both levels because they are important to personnel safety.

1. Electric Shock Prevention

WARNING

- While power is on or when the inverter is running, do not open the front cover. Otherwise you may get an electric shock.
- Do not run the inverter with the front cover or wiring cover removed. Otherwise, you may access the exposed high-voltage terminals or the charging part of the circuitry and get an electric shock.
- Even if power is off, do not remove the front cover except for wiring or periodic inspection. You may access the charged inverter circuits and get an electric shock.
- Before starting wiring or inspection, check to make sure that the operation panel indicator is off, wait for at least 10 minutes after the power supply has been switched off, and check that there are no residual voltage using a tester or the like. The capacitor is charged with high voltage for some time after power off and it is dangerous.
- This inverter must be grounded. Grounding must conform to the requirements of national and local safety regulations and electrical codes. (JIS, NEC section 250, IEC 536 class 1 and other applicable standards)
- Any person who is involved in the wiring or inspection of this equipment should be fully competent to do the work.
- Always install the inverter before wiring. Otherwise, you may get an electric shock or be injured.
- Perform setting dial and key operations with dry hands to prevent an electric shock. Otherwise you may get an electric shock.
- Do not subject the cables to scratches, excessive stress, heavy loads or pinching. Otherwise you may get an electric shock.
- Do not replace the cooling fan while power is on. It is dangerous to replace the cooling fan while power is on.
- Do not touch the printed circuit board with wet hands. You may get an electric shock.

2. Fire Prevention

CAUTION

- Mount the inverter to incombustible material. Mounting it to or near combustible material can cause a fire.
- If the inverter has become faulty, switch off the inverter power. A continuous flow of large current could cause a fire.
- Do not connect a resistor directly to the DC terminals P/+, N/-. This could cause a fire.

3. Injury Prevention

CAUTION

- Apply only the voltage specified in the instruction manual to each terminal. Otherwise, burst, damage, etc. may occur.
- Ensure that the cables are connected to the correct terminals. Otherwise, burst, damage, etc. may occur.
- Always make sure that polarity is correct to prevent damage, etc. Otherwise, burst, damage, etc. may occur.
- While power is on or for some time after power-off, do not touch the inverter as it is hot and you may get burnt.

4. Additional Instructions

Also note the following points to prevent an accidental failure, injury, electric shock, etc.

(1) Transportation and installation

CAUTION

- When carrying products, use correct lifting gear to prevent injury.
- Do not stack the inverter boxes higher than the number recommended.
- Ensure that installation position and material can withstand the weight of the inverter. Install according to the information in the instruction manual.
- Do not install or operate the inverter if it is damaged or has parts missing. This can result in breakdowns.
- When carrying the inverter, do not hold it by the front cover or setting dial; it may fall off or fail.
- Do not stand or rest heavy objects on the product.
- Check the inverter mounting orientation is correct.
- Prevent other conductive bodies such as screws and metal fragments or other flammable substance such as oil from entering the inverter.
- As the inverter is a precision instrument, do not drop or subject it to impact.
- Use the inverter under the following environmental conditions. Otherwise, the inverter may be damaged.

Environment	Ambient temperature	LD SLD (initial setting)	-10°C to +50°C (14°F to 122°F)(non-freezing) -10°C to +40°C (14°F to 104°F)(non-freezing)
	Ambient humidity		90% RH or less (non-condensing)
	Storage temperature		-20°C to +65°C *1 (-4°F to 149°F)
	Atmosphere		Indoors (free from corrosive gas, flammable gas, oil mist, dust and dirt)
	Altitude, vibration		Maximum 1000m (3280.80feet) above sea level for standard operation. After that derate by 3% for every extra 500m (1640.40feet) up to 2500m (8202feet) (92%) 5.9m/s ² or less *2 (conforming to JIS C 60068-2-6)

*1 Temperature applicable for a short time, e.g. in transit.

*2 2.9m/s² or less for the FR-F740-04320 or more.

(2) Wiring

CAUTION

- Do not install a power factor correction capacitor or surge suppressor on the inverter output side.
- The connection orientation of the output cables U, V, W to the motor will affect the direction of rotation of the motor.

(3) Test operation and adjustment

CAUTION

- Before starting operation, confirm and adjust the parameters. A failure to do so may cause some machines to make unexpected motions.

(4) Operation

WARNING

- When you have chosen the retry function, stay away from the equipment as it will restart suddenly after an alarm stop.
- The  key is valid only when the appropriate function setting has been made. Prepare an emergency stop switch separately.
- Make sure that the start signal is off before resetting the inverter alarm. A failure to do so may restart the motor suddenly.
- The load used should be a three-phase induction motor only. Connection of any other electrical equipment to the inverter output may damage the inverter as well as equipment.
- Do not modify the equipment.
- Do not perform parts removal which is not instructed in this manual. Doing so may lead to fault or damage of the inverter.

CAUTION

- The electronic thermal relay function does not guarantee protection of the motor from overheating.
- Do not use a magnetic contactor on the inverter input for frequent starting/stopping of the inverter.
- Use a noise filter to reduce the effect of electromagnetic interference. Otherwise nearby electronic equipment may be affected.
- Take measures to suppress harmonics. Otherwise power supply harmonics from the inverter may heat/damage the power factor correction capacitor and generator.
- When a 400V class motor is inverter-driven, please use an insulation-enhanced motor or measures taken to suppress surge voltages. Surge voltages attributable to the wiring constants may occur at the motor terminals, deteriorating the insulation of the motor.
- When parameter clear or all clear is performed, reset the required parameters before starting operations. Each parameter returns to the initial value.
- The inverter can be easily set for high-speed operation. Before changing its setting, fully examine the performances of the motor and machine.
- In addition to the inverter's holding function, install a holding device to ensure safety.
- Before running an inverter which had been stored for a long period, always perform inspection and test operation.
- For prevention of damage due to static electricity, touch nearby metal before touching this product to eliminate static electricity from your body.

(5) Emergency stop

CAUTION

- Provide a safety backup such as an emergency brake which will prevent the machine and equipment from hazardous conditions if the inverter fails.
- When the breaker on the inverter input side trips, check for the wiring fault (short circuit), damage to internal parts of the inverter, etc. Identify the cause of the trip, then remove the cause and power on the breaker.
- When the protective function is activated, take the corresponding corrective action, then reset the inverter, and resume operation.

(6) Maintenance, inspection and parts replacement

CAUTION

- Do not carry out a megger (insulation resistance) test on the control circuit of the inverter.

(7) Disposing of the inverter

CAUTION

- Treat as industrial waste.

General instructions

Many of the diagrams and drawings in this instruction manual (basic) show the inverter without a cover, or partially open. Never run the inverter in this status. Always replace the cover and follow this instruction manual (basic) when operating the inverter.

— CONTENTS —

1	PRODUCT CHECKING AND PARTS IDENTIFICATION	1
2	INSTALLATION AND WIRING	2
2.1	Peripheral devices	3
2.2	Method of removal and reinstallation of the front cover	5
2.3	Installation of the inverter and instructions.....	7
2.4	Wiring	9
2.4.1	Terminal connection diagram	9
2.4.2	Specification of main circuit terminal	10
2.4.3	Terminal arrangement of the main circuit terminal, power supply and the motor wiring.	10
2.4.4	Control circuit terminals	17
2.4.5	When connecting the operation panel using a connection cable	24
2.4.6	Connector with/without EMC filter	24
2.4.7	RS-485 terminal block	25
2.4.8	Communication operation.....	25
2.5	Power-off and magnetic contactor (MC)	26
2.6	Precautions for use of the inverter	27
3	DRIVE THE MOTOR	28
3.1	Step of operation.....	28
3.2	Operation panel (FR-DU07).....	29
3.2.1	Parts of the operation panel (FR-DU07).....	29
3.2.2	Basic operation (factory setting)	30
3.2.3	Operation lock (Press [MODE] for an extended time (2s)).....	31
3.2.4	Monitoring of output current and output voltage	32
3.2.5	First priority monitor	32
3.2.6	Setting dial push	32
3.3	Overheat protection of the motor by the inverter (Pr.9)	33
3.4	When the rated motor frequency is 50Hz (Pr.3)	34
3.5	Operation by the start command from the operation panel (PU operation mode).....	35
3.5.1	Set the set frequency to operate (example: performing operation at 30Hz).....	35
3.5.2	Use the setting dial like a potentiometer to perform operation.	36
3.5.3	Use switches to give a start command and a frequency command (multi-speed setting).....	37
3.5.4	Perform frequency setting by analog (voltage input)	39
3.5.5	Perform frequency setting by analog (current input)	41
3.6	Operation by the start command of the terminal block (external operation)	43
3.6.1	Use the set frequency set by the operation panel (Pr. 79=3)	43
3.6.2	Use switches to give a start command and a frequency command (multi-speed setting) (Pr. 4 to Pr.6)	45
3.6.3	Perform frequency setting by analog (voltage input)	47
3.6.4	Change the frequency (60Hz) of the maximum value of potentiometer (at 5V)	48
3.6.5	Perform frequency setting by analog (current input)	49
3.6.6	Change the frequency (60Hz) of the maximum value of potentiometer (at 20mA)	50

4	ADJUSTMENT	51
4.1	Simple mode parameter list	51
4.2	Increase the starting torque (Pr. 0)	53
4.3	Limit the maximum and minimum output frequency (Pr.1, Pr.2).....	54
4.4	Change acceleration and deceleration time (Pr.7, Pr.8)	55
4.5	Energy saving operation (Pr. 60)	56
4.5.1	Energy saving operation mode (setting "4")	56
4.5.2	Optimum excitation control mode (setting "9").....	56
4.6	Selection of the operation command and frequency command locations (Pr.79)	58
4.7	Parameter clear	59
4.8	All parameter clear.....	60
4.9	Parameter copy.....	61
4.10	Parameter verification	62
5	TROUBLESHOOTING	63
5.1	List of alarm display	63
5.2	Causes and corrective actions	64
5.3	Reset method of protective function	75
5.4	Correspondences between digital and actual characters	75
5.5	Check and clear of the alarm history	76
5.6	Check first when you have troubles.	78
5.6.1	Motor does not rotate as commanded.....	78
5.6.2	Motor generates abnormal noise	78
5.6.3	Motor generates heat abnormally	78
5.6.4	Motor rotates in opposite direction	79
5.6.5	Speed greatly differs from the setting.....	79
5.6.6	Acceleration/deceleration is not smooth.....	79
5.6.7	Motor current is large.....	79
5.6.8	Speed does not increase.....	79
5.6.9	Speed varies during operation.....	79
5.6.10	Operation panel (FR-DU07) display is not operating.....	79
5.6.11	Parameter write cannot be performed	79
6	PRECAUTIONS FOR MAINTENANCE AND INSPECTION	80
6.1	Inspection Item.....	80
6.1.1	Daily inspection	80
6.1.2	Periodic inspection	80
6.1.3	Daily and periodic inspection.....	81
6.1.4	Display of the life of the inverter parts	82
6.1.5	Checking the inverter and converter modules	84

6.1.6	Cleaning	84
6.1.7	Replacement of parts	85
6.1.8	Inverter replacement.....	89
6.2	Measurement of main circuit voltages, currents and powers	90
6.2.1	Insulation resistance test using megger	90
6.2.2	Pressure test	90
6.2.3	Measurement of voltages and currents	90

7 SPECIFICATIONS **92**

7.1	Rating.....	92
7.2	Common specifications.....	94
7.3	Outline dimension drawings	96
7.3.1	Inverter outline dimension drawings	96
7.3.2	Operation panel (FR-DU07) outline dimension drawings	104
7.3.3	Parameter unit (FR-PU04) outline dimension drawings	104

APPENDICES **105**

Appendix 1	List of parameters classified by purpose of use	105
Appendix 2	Extended parameters.....	107
Appendix 3	For customers who have replaced the older model with this inverter	130
Appendix 3-1	Replacement of the FR-F500 series	130
Appendix 3-2	Replacement of the FR-A100 <EXCELENT> series	131
Appendix 4	Instructions for UL and cUL.....	132
Appendix 5	Instructions for Compliance with the European Directives	133

<Abbreviations>

DU: Operation panel (FR-DU07)

PU: Operation panel(FR-DU07) and parameter unit (FR-PU04)

Inverter: Mitsubishi inverter FR-F700 series

FR-F700: Mitsubishi inverter FR-F700 series

Pr.: Parameter Number

PU operation: Operation using the PU (FR-DU07/FR-PU04).

External operation: Operation using the control circuit signals

Combined operation: Combined operation using the PU (FR-DU07/FR-PU04) and external operation

Standard motor: SF-JR

Constant-torque motor: SF-HRCA

<Trademarks>

LONWORKS is registered trademarks of Echelon Corporation in the U.S.A. and other countries.

Company and product names herein are the trademarks and registered trademarks of their respective owners.

1 PRODUCT CHECKING AND PARTS IDENTIFICATION

Unpack the inverter and check the capacity plate on the front cover and the rating plate on the inverter side face to ensure that the product agrees with your order and the inverter is intact.

• Inverter Type

FR - **F740** - **00126** - NA

Symbol	Voltage Class	Symbol	Type number
F720	Three-phase 200V class	200V class 00046 to 04750	Displays the rated current
F740	Three-phase 400V class	400V class 00023 to 12120	

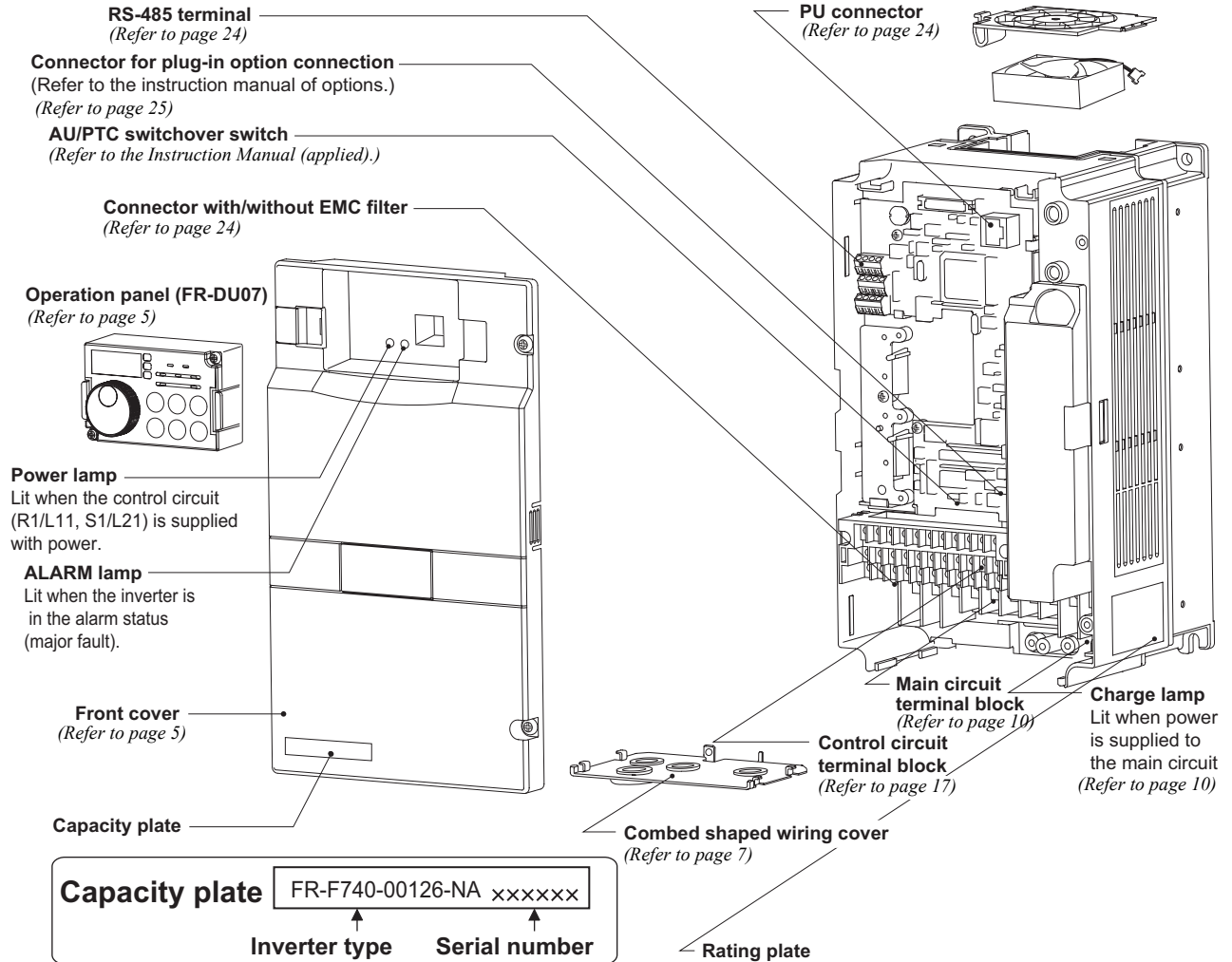

Capacity plate FR-F740-00126-NA xxxxxx

Inverter type Serial number

• Accessory

- Fan cover fixing screws (FR-F720-01250 (FR-F740-00620) or less) (Refer to page 133)

Capacity	Screw Size (mm)	Number
200V	00105 to 00250	M3 × 35 1
	00340 to 00630	M4 × 40 2
	00770 to 01250	M4 × 50 1
400V	00083, 00126	M3 × 35 1
	00170 to 00380	M4 × 40 2
	00470, 00620	M4 × 50 1

- DC reactor supplied (FR-F720-03160 (FR-F740-01800) or more)

Rating plate

MITSUBISHI INVERTER	
MODEL	FR-F740-00126-NA
Inverter type	FR-F740-00126-NA
Input rating	INPUT : XXXXX
Output rating	OUTPUT : XXXXX
Serial number	SERIAL : _____
	LD (50°C) XXA : _____ SLD (40°C) XXA : _____
	PASSED

	Overload current rating	Ambient temperature
LD	120% 60s, 150% 3s	50°C (122°F)
SLD	110% 60s, 120% 3s	40°C (104°F)

REMARKS

For removal and reinstallation of covers, refer to page 5.

2 INSTALLATION AND WIRING



Three-phase AC power supply
Use within the permissible power supply specifications of the inverter.
(Refer to page 92)

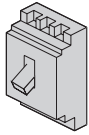

Moulded case circuit breaker (MCCB) or earth leakage circuit breaker (ELB), fuse
The breaker must be selected carefully since an in-rush current flows in the inverter at power on.
(Refer to page 3)

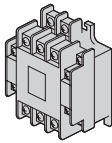

Magnetic contactor (MC)
Install the magnetic contactor to ensure safety. Do not use this magnetic contactor to start and stop the inverter. Doing so will cause the inverter life to be shorten.
(Refer to page 3)



Reactor (FR-HAL, FR-HEL)
Reactors (option) should be used when power harmonics measures are taken, the power factor is to be improved or the inverter is installed near a large power supply system (1000kVA or more). The inverter may be damaged if you do not use reactors.
Select the reactor according to the model. For the FR-F720-02330 (FR-F740-01160) or less, remove the jumpers across terminals P/+ -P1 to connect to the DC reactor.
(Refer to the Instruction Manual (applied).)

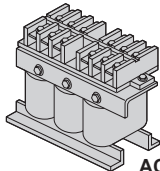

AC reactor (FR-HAL)

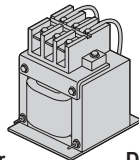

DC reactor (FR-HEL)
For the FR-F720-03160 (FR-F740-01800) or more, a DC reactor is supplied.



Noise filter (FR-BLF)
It is not necessary for the FR-F720-02330 (FR-F740-01160) or less.

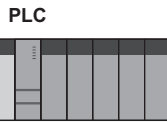

RS-485 terminal block
The inverter can be connected with computers such as PLC. It supports Mitsubishi inverter protocol and Modbus-RTU (binary) protocol.



Inverter (FR-F700)

The life of the inverter is influenced by ambient temperature. The ambient temperature should be as low as possible within the permissible range. Especially when mounting the inverter inside an enclosure, take cautions of the ambient temperature. (Refer to page 7)
Wrong wiring might lead to damage of the inverter. The control signal lines must be kept fully away from the main circuit to protect them from noise. (Refer to page 9)
Refer to page 24 for the built-in EMC filter.



Noise filter (FR-BSF01, FR-BLF)

Install a noise filter to reduce the electromagnetic noise generated from the inverter. Effective in the range from about 1MHz to 10MHz. When more wires are passed through, a more effective result can be obtained.

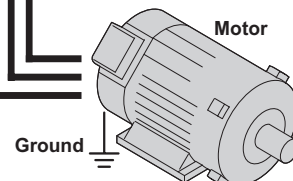
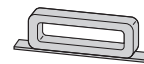

Devices connected to the output

Do not install a power factor correction capacitor, surge suppressor or radio noise filter on the output side of the inverter. When installing a moulded case circuit breaker on the output side of the inverter, contact each manufacturer for selection of the moulded case circuit breaker.

Ground

To prevent an electric shock, always ground the motor and inverter.

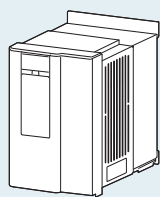

High power factor converter (FR-HC*1, MT-HC*2)
Power supply harmonics can be greatly suppressed. Install this as required.

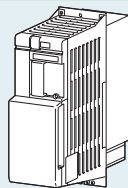

Power regeneration common converter (FR-CV*1)

Power regeneration converter (MT-RC*2)
Greater braking capability is obtained. Install this as required.

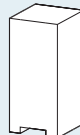

Resistor unit (FR-BR*1, MT-BR5*2)
The regenerative braking capability of the inverter can be exhibited fully. Install this as required.

Brake unit (FR-BU*1, MT-BU5*2)



*1 Compatible with the FR-F720-02330 (FR-F740-01160) or less.
*2 Compatible with the FR-F720-03160 (FR-F740-01800) or more.

CAUTION

- Do not install a power factor correction capacitor or surge suppressor on the inverter output side. This will cause the inverter to trip or the capacitor, and surge suppressor to be damaged. If any of the above devices are connected, immediately remove them.
- Electromagnetic wave interference
The input/output (main circuit) of the inverter includes high frequency components, which may interfere with the communication devices (such as AM radios) used near the inverter. In this case, set the EMC filter valid to minimize interference.
(Refer to the Instruction Manual (applied).)
- Refer to the instruction manual of each option and peripheral devices for details of peripheral devices.

2.1 Peripheral devices

Check the motor capacity of the inverter you purchased. Appropriate peripheral devices must be selected according to the capacity. Refer to the following list and prepare appropriate peripheral devices:

200V class

Motor Output (kW(HP)) *1	Applicable Inverter Type	Breaker Selection*2,4			Input Side Magnetic Contactor*3	
		Reactor connection		with commercial power-supply operation	Reactor connection	
		without	with		without	with
0.75 (1)	FR-F720-00046-NA	30AF 10A	30AF 10A	30AF 10A	S-N10	S-N10
1.5 (2)	FR-F720-00077-NA	30AF 15A	30AF 15A	30AF 15A	S-N10	S-N10
2.2 (3)	FR-F720-00105-NA	30AF 20A	30AF 15A	30AF 20A	S-N10	S-N10
3.7 (5)	FR-F720-00167-NA	30AF 30A	30AF 30A	30AF 30A	S-N20, N21	S-N10
5.5 (7.5)	FR-F720-00250-NA	50AF 50A	50AF 40A	50AF 50A	S-N25	S-N20, N21
7.5 (10)	FR-F720-00340-NA	100AF 60A	50AF 50A	100AF 60A	S-N25	S-N25
11 (15)	FR-F720-00490-NA	100AF 75A	100AF 75A	100AF 75A	S-N35	S-N35
15 (20)	FR-F720-00630-NA	225AF 125A	100AF 100A	225AF 125A	S-N50	S-N50
18.5 (25)	FR-F720-00770-NA	225AF 150A	225AF 125A	225AF 150A	S-N65	S-N50
22 (30)	FR-F720-00930-NA	225AF 175A	225AF 150A	225AF 175A	S-N80	S-N65
30 (40)	FR-F720-01250-NA	225AF 225A	225AF 175A	225AF 225A	S-N95	S-N80
37 (50)	FR-F720-01540-NA	400AF 250A	225AF 225A	400AF 250A	S-N150	S-N125
45 (60)	FR-F720-01870-NA	400AF 300A	400AF 300A	400AF 350A	S-N180	S-N150
55 (75)	FR-F720-02330-NA	400AF 400A	400AF 350A	600AF 500A	S-N220	S-N180
75 (100)	FR-F720-03160-NA	—	400AF 400A	400AF 400A	—	S-N300
90 (125)	FR-F720-03800-NA	—	400AF 400A	600AF 500A	—	S-N300
110 (150)	FR-F720-04750-NA	—	600AF 500A	600AF 600A	—	S-N400

*1 Selections for use of the Mitsubishi 4-pole standard motor with power supply voltage of 200VAC 50Hz.

*2 Select the MCCB according to the inverter power supply capacity.

Install one MCCB per inverter.

For installations in the United States or Canada, use the fuse certified by the UL and cUL.

(Refer to page 132.)

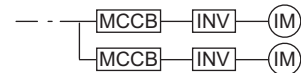

*3 The electrical durability of magnetic contactor is 500,000 times. When the magnetic contactor is used for emergency stop during motor driving, the electrical durability is 25 times.

When using the MC for emergency stop during motor driving or using on the motor side during commercial-power supply operation, select the MC with class AC-3 rated current for the motor rated current.

*4 When the breaker on the inverter primary side trips, check for the wiring fault (short circuit), damage to internal parts of the inverter, etc. Identify the cause of the trip, then remove the cause and power on the breaker.



400V class

Motor Output (kW(HP)) ^{*1}	Applicable Inverter Type	Breaker Selection ^{*2,4}			Input Side Magnetic Contactor ^{*3}	
		Reactor connection		with commercial power-supply operation	Reactor connection	
		without	with		without	with
0.75 (1)	FR-F740-00023-NA	30AF 5A	30AF 5A	30AF 5A	S-N10	S-N10
1.5 (2)	FR-F740-00038-NA	30AF 10A	30AF 10A	30AF 10A	S-N10	S-N10
2.2 (3)	FR-F740-00052-NA	30AF 10A	30AF 10A	30AF 15A	S-N10	S-N10
3.7 (5)	FR-F740-00083-NA	30AF 20A	30AF 15A	30AF 20A	S-N10	S-N10
5.5 (7.5)	FR-F740-00126-NA	30AF 30A	30AF 20A	30AF 30A	S-N20	S-N11, N12
7.5 (10)	FR-F740-00170-NA	30AF 30A	30AF 30A	30AF 30A	S-N20	S-N20
11 (15)	FR-F740-00250-NA	50AF 50A	50AF 40A	50AF 50A	S-N20	S-N20
15 (20)	FR-F740-00310-NA	100AF 60A	50AF 50A	100AF 60A	S-N25	S-N20
18.5 (25)	FR-F740-00380-NA	100AF 75A	100AF 60A	100AF 75A	S-N25	S-N25
22 (30)	FR-F740-00470-NA	100AF 100A	100AF 75A	100AF 100A	S-N35	S-N25
30 (40)	FR-F740-00620-NA	225AF 125A	225AF 100A	225AF 125A	S-N50	S-N50
37 (50)	FR-F740-00770-NA	225AF 150A	225AF 125A	225AF 150A	S-N65	S-N50
45 (60)	FR-F740-00930-NA	225AF 175A	225AF 150A	225AF 175A	S-N80	S-N65
55 (75)	FR-F740-01160-NA	225AF 200A	225AF 175A	225AF 200A	S-N80	S-N80
75 (100)	FR-F740-01800-NA	—	225AF 225A	225AF 225A	—	S-N95
90 (125)	FR-F740-01800-NA	—	225AF 225A	400AF 300A	—	S-N150
110 (150)	FR-F740-02160-NA	—	225AF 225A	400AF 350A	—	S-N180
132 (200)	FR-F740-02600-NA	—	400AF 400A	400AF 400A	—	S-N220
160 (250)	FR-F740-03250-NA	—	400AF 400A	600AF 500A	—	S-N300
185 (300)	FR-F740-03610-NA	—	400AF 400A	600AF 500A	—	S-N300
220 (350)	FR-F740-04320-NA	—	600AF 500A	600AF 600A	—	S-N400
250 (400)	FR-F740-04810-NA	—	600AF 600A	600AF 600A	—	S-N600
280 (450)	FR-F740-05470-NA	—	600AF 600A	800AF 800A	—	S-N600
315 (500)	FR-F740-06100-NA	—	800AF 700A	800AF 800A	—	S-N600
355 (550)	FR-F740-06830-NA	—	800AF 800A	800AF 800A	—	S-N600
400 (600)	FR-F740-07700-NA	—	1000AF 900A	1000AF 1000A	—	S-N800
450 (700)	FR-F740-08660-NA	—	1000AF 1000A	1000AF 1000A	—	1000A Rated product
500 (750)	FR-F740-09620-NA	—	1200AF 1200A	1200AF 1200A	—	1000A Rated product
560 (800)	FR-F740-10940-NA	—	1600AF 1500A	1600AF 1600A	—	1200A Rated product
630 (850)	FR-F740-12120-NA	—	2000AF 2000A	2000AF 2000A	—	1400A Rated product

*1 Selections for use of the Mitsubishi 4-pole standard motor with power supply voltage of 400VAC 50Hz.

*2 Select the MCCB according to the inverter power supply capacity.
Install one MCCB per inverter.
For installations in the United States or Canada, use the fuse certified by the UL and cUL.
(Refer to page 132.)

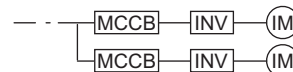

*3 The electrical durability of magnetic contactor is 500,000 times. When the magnetic contactor is used for emergency stop during motor driving, the electrical durability is 25 times.
When using the MC for emergency stop during motor driving or using on the motor side during commercial-power supply operation, select the MC with class AC-3 rated current for the motor rated current.

*4 When the breaker on the inverter primary side trips, check for the wiring fault (short circuit), damage to internal parts of the inverter, etc. Identify the cause of the trip, then remove the cause and power on the breaker.

2.2 Method of removal and reinstallation of the front cover

•Removal of the operation panel

- 1) Loosen the two screws on the operation panel.
(These screws cannot be removed.)
- 2) Push the left and right hooks of the operation panel and pull the operation panel toward you to remove.

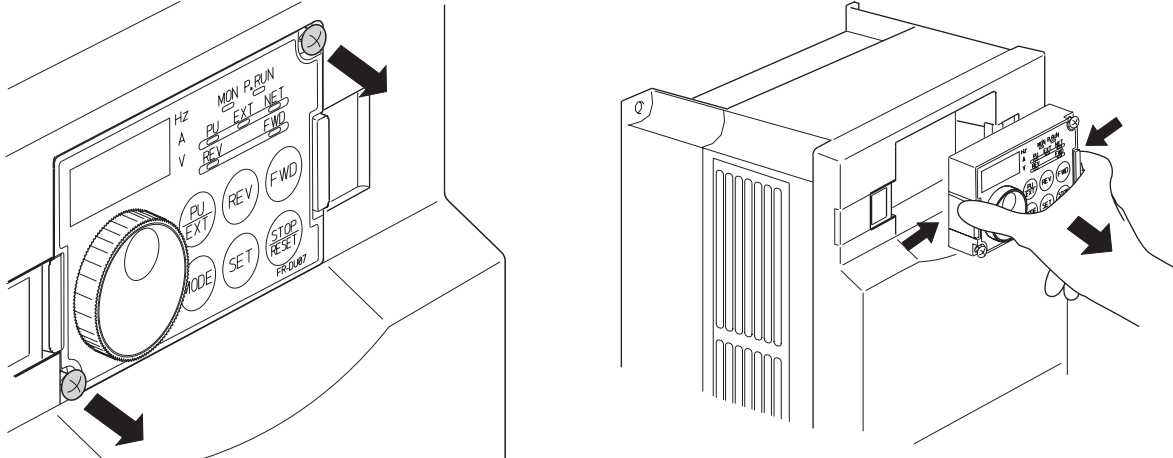

When reinstalling the operation panel, insert it straight to reinstall securely and tighten the fixed screws of the operation panel.

FR-F720-01250-NA or less, FR-F740-00620-NA or less

•Removal

- 1) Loosen the installation screws of the front cover.
- 2) Pull the front cover toward you to remove by pushing an installation hook using left fixed hooks as supports.

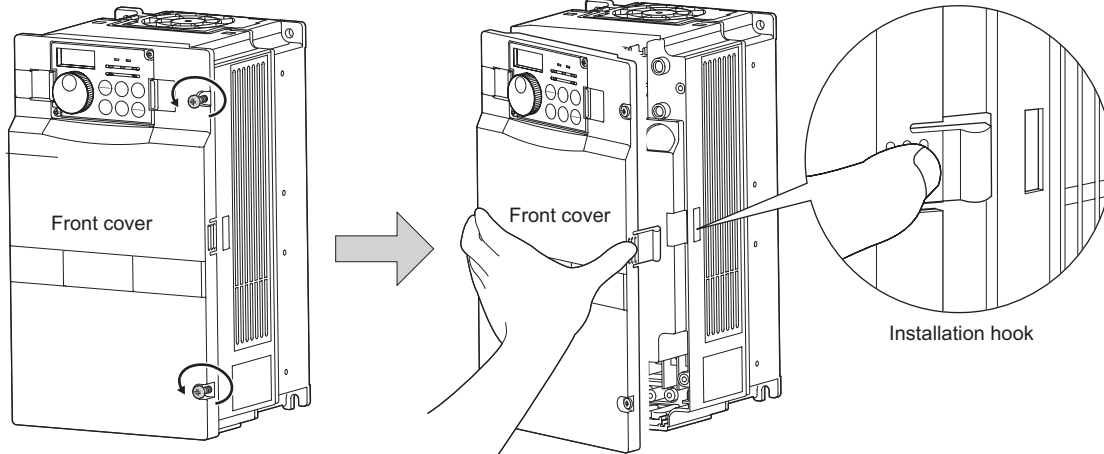

•Reinstallation

- 1) Insert the two fixed hooks on the left side of the front cover into the sockets of the inverter.
- 2) Using the fixed hooks as supports, securely press the front cover against the inverter.
(Although installation can be done with the operation panel mounted, make sure that a connector is securely fixed.)
- 3) Tighten the installation screws and fix the front cover.

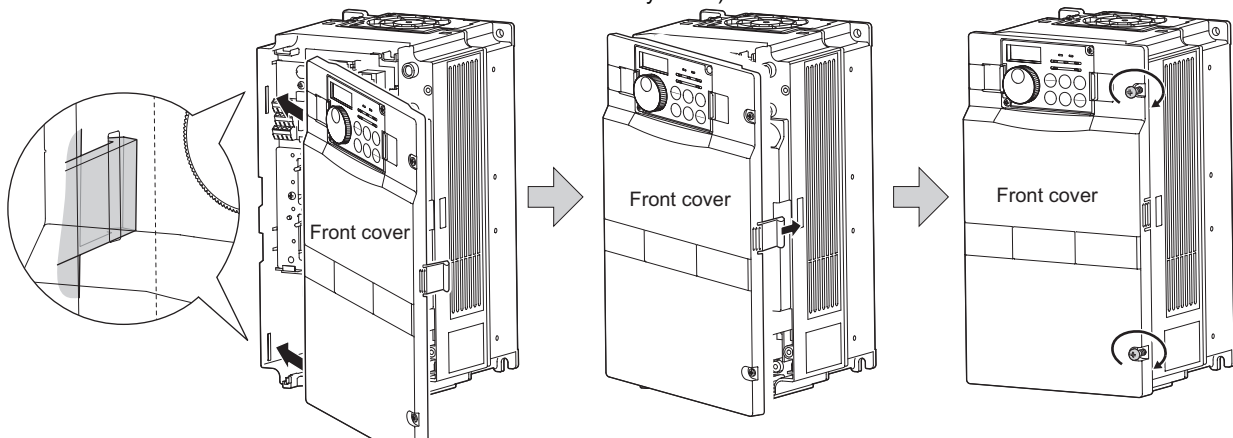



FR-F720-01540-NA or more, FR-F740-00770-NA or more

•Removal

1) Remove installation screws on the front cover 1 to remove the front cover 1.

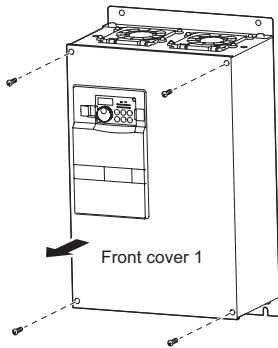

2) Loosen the installation screws of the front cover 2.

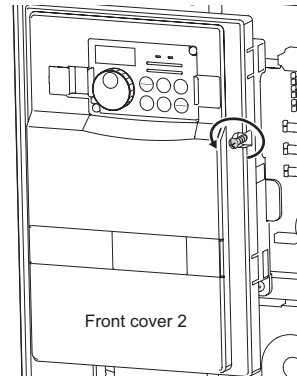

3) Pull the front cover 2 toward you to remove by pushing an installation hook on the right side using left fixed hooks as supports.

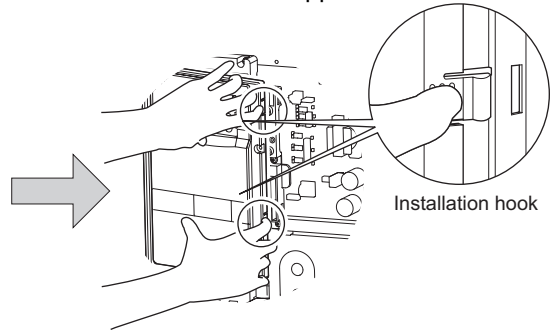

•Reinstallation

1) Insert the two fixed hooks on the left side of the front cover 2 into the sockets of the inverter.

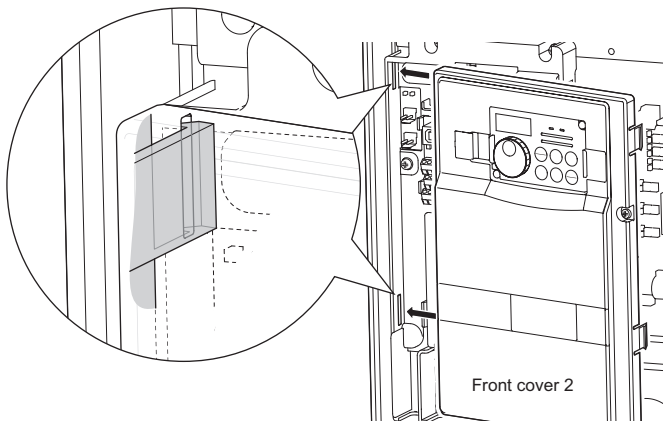

2) Using the fixed hooks as supports, securely press the front cover 2 against the inverter. (Although installation can be done with the operation panel mounted, make sure that a connector is securely fixed.)

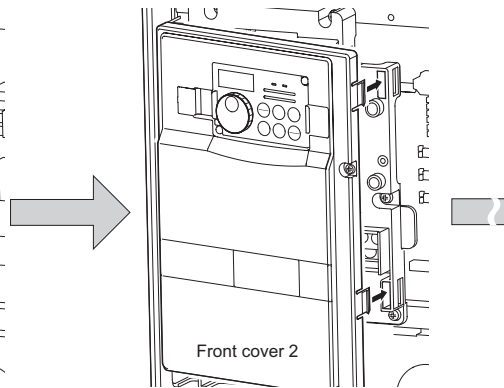

3) Fix the front cover 2 with the installation screws.

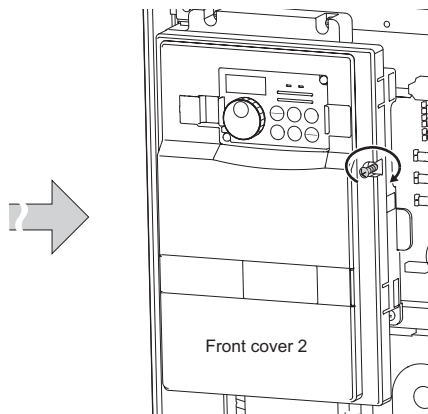

4) Fix the front cover 1 with the installation screws.

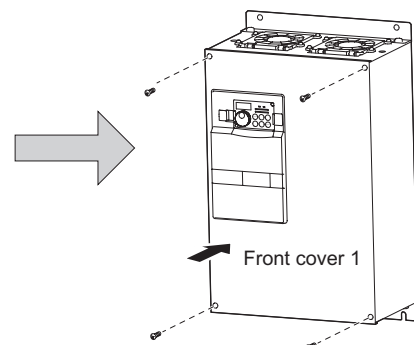

REMARKS

For the FR-F740-04320 or more, the front cover 1 is separated into two parts.

CAUTION

1. Fully make sure that the front cover has been reinstalled securely. Always tighten the installation screws of the front cover.
2. The same serial number is printed on the capacity plate of the front cover and the rating plate of the inverter. Before reinstalling the front cover, check the serial numbers to ensure that the cover removed is reinstalled to the inverter from where it was removed.

2.3 Installation of the inverter and instructions

• Installation of the Inverter

Installation on the enclosure
 FR-F720-01250 or less
 FR-F740-00620 or less

FR-F720-01540 or more
 FR-F740-00770 or more

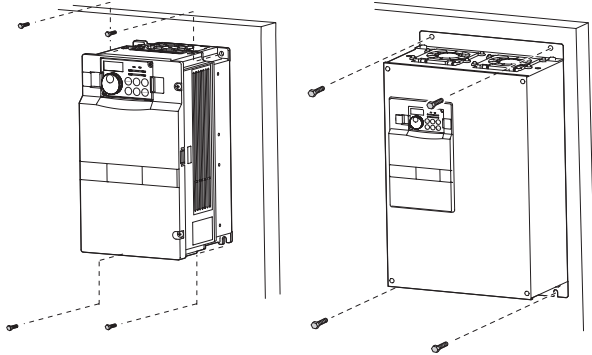

Fix six positions for the FR-F740-04320 to 08660 and fix eight positions for the FR-F740-09620 to 12120.

CAUTION

When encasing multiple inverters, install them in parallel as a cooling measure. Install the inverter vertically.

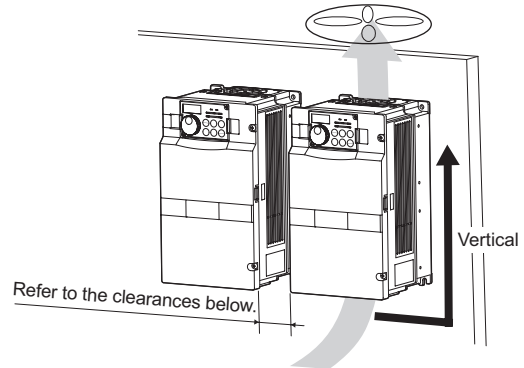

• Install the inverter under the following conditions.

Ambient temperature and humidity

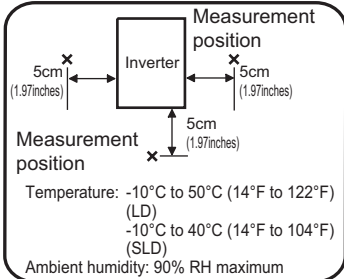

Leave enough clearances and take cooling measures.

Clearances (front)

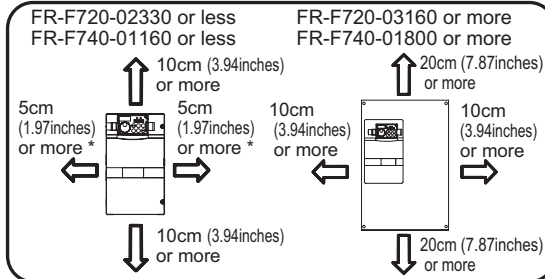

*1cm (0.39 inches) or more for FR-F720-00167 (FR-740-00083) or less

Clearances (side)

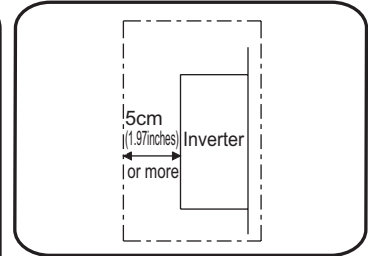

REMARKS

For replacing the cooling fan of the FR-F740-04320 or more, 30cm of space is necessary in front of the inverter. Refer to *page 86* for fan replacement.

- The inverter consists of precision mechanical and electronic parts. Never install or handle it in any of the following conditions as doing so could cause an operation fault or failure.

 Direct sunlight	 Vibration (5.9m/s ² or more*) * 2.9m/s ² or more for the FR-F740-04320 or more	 High temperature, high humidity	 Horizontal placement
 Vertical mounting (When installing two or more inverters, install them in parallel.)	 Transportation by holding the front cover	 Oil mist, flammable gas, corrosive gas, fluff, dust, etc.	 Mounting to combustible material

Wiring cover and Handling (FR-F720-00930 (FR-F740-00620) or less)

- 1) When cable conduits are not connected
Cut the protective bushes of the wiring cover with nippers or a cutter before running the cables.

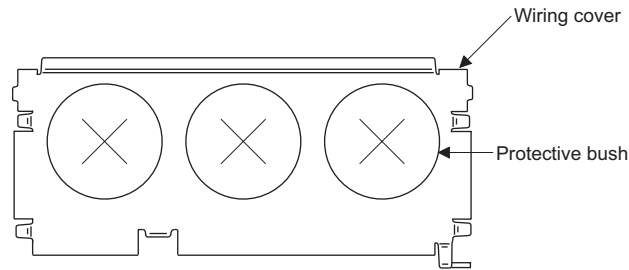

 **WARNING**

Do not remove the protective bushes. Otherwise, the cable sheathes may be scratched by the wiring cover edges, resulting in a short circuit or ground fault.

- 2) When cable conduits are connected
Remove the corresponding protective bushes and connect the cable conduits.

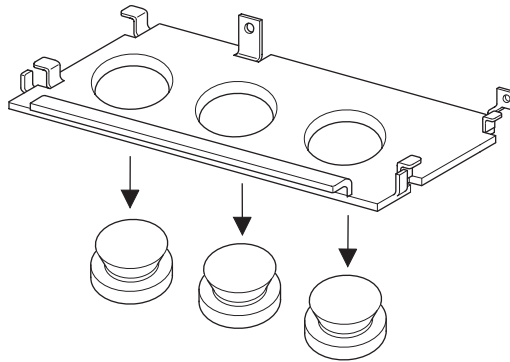

REMARKS

- When using conduits for the FR-F720-00046 and 00077, fix the conduits to the wiring cover after connecting the earth cable to the inverter earth terminal.

2.4 Wiring

2.4.1 Terminal connection diagram

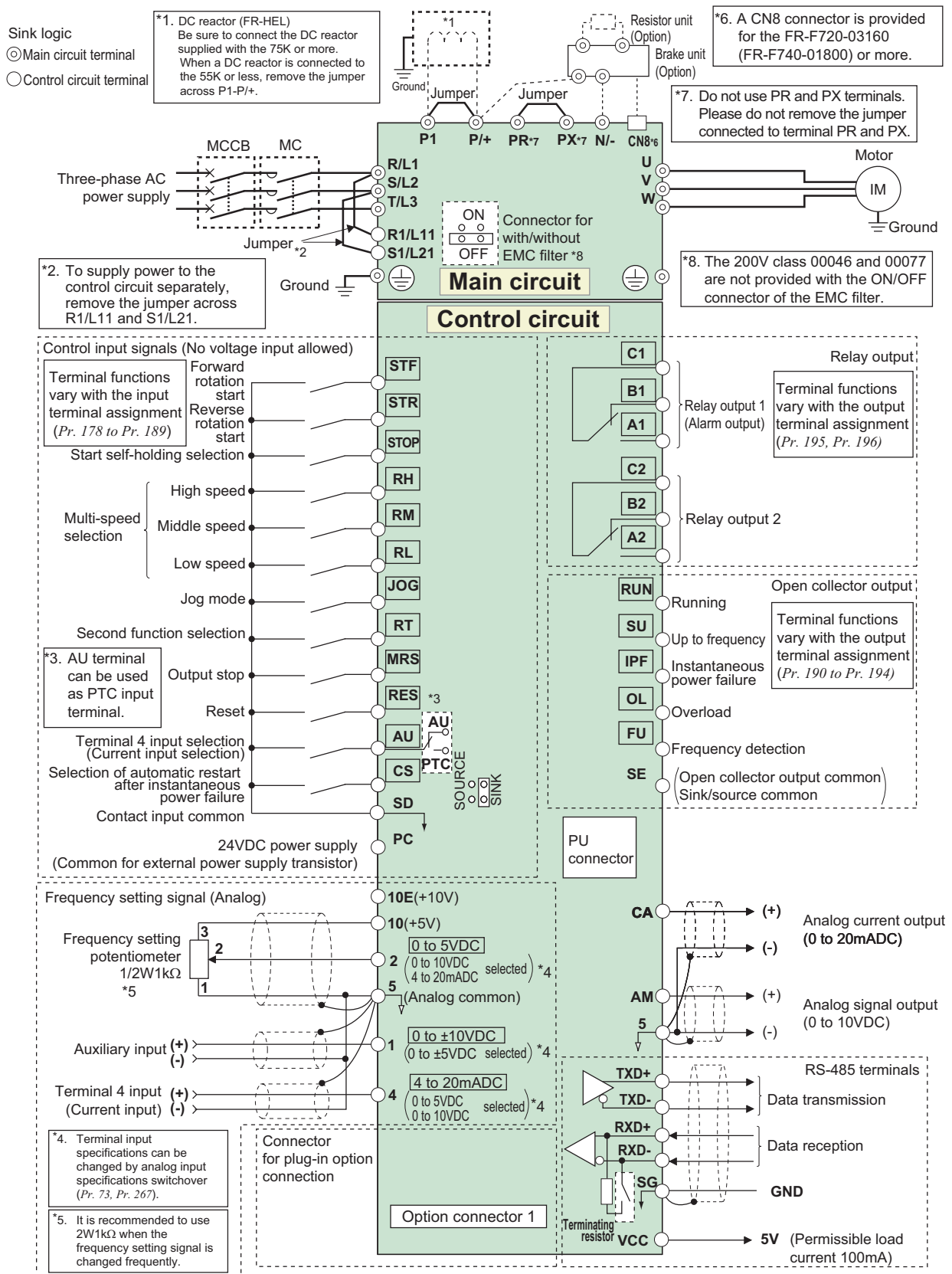

CAUTION

- To prevent a malfunction due to noise, keep the signal cables more than 10cm (3.94inches) away from the power cables.
- After wiring, wire offcuts must not be left in the inverter.
- Wire offcuts can cause an alarm, failure or malfunction. Always keep the inverter clean.
- When drilling mounting holes in an enclosure etc., take care not to allow chips and other foreign matter to enter the inverter.



2.4.2 Specification of main circuit terminal

Terminal Symbol	Terminal Name	Description
R/L1, S/L2, T/L3	AC power input	Connect to the commercial power supply. Keep these terminals open when using the high power factor converter (FR-HC, MT-HC) or power regeneration common converter (FR-CV).
U, V, W	Inverter output	Connect a three-phase squirrel-cage motor.
R1/L11, S1/L21	Power supply for control circuit	Connected to the AC power supply terminals R/L1 and S/L2. To retain the alarm display and alarm output or when using the high power factor converter (FR-HC, MT-HC) or power regeneration common converter (FR-CV), remove the jumpers from terminals R/L1-R1/L11 and S/L2-S1/L21 and apply external power to these terminals. Do not turn off the power supply for control circuit (R1/L11, S1/L21) with the main circuit power (R/L1, S/L2, T/L3) on. Doing so may damage the inverter. The circuit should be configured so that the main circuit power (R/L1, S/L2, T/L3) is also turned off when the power supply for control circuit (R1/L11, S1/L21) is off. FR-F720-00770 (FR-F740-00380) or less : 60VA, FR-F720-00930 (FR-F740-00470) or more : 80VA
P/+, N/-	Brake unit connection	Connect the brake unit (FR-BU, BU and MT-BU5), power regeneration common converter (FR-CV), high power factor converter (FR-HC and MT-HC) or power regeneration converter (MT-RC).
P/+, P1	DC reactor connection	For the FR-F720-02330 (FR-F740-01160) or less, remove the jumper across terminals P/+ - P1 and connect the DC reactor. (For the FR-F720-03160 (FR-F740-01800) or more, a DC reactor is supplied as standard.)
PR, PX		Please do not remove or use terminals PR and PX or the jumper connected.
	Ground	For grounding the inverter chassis. Must be grounded.

2.4.3 Terminal arrangement of the main circuit terminal, power supply and the motor wiring.

200V class

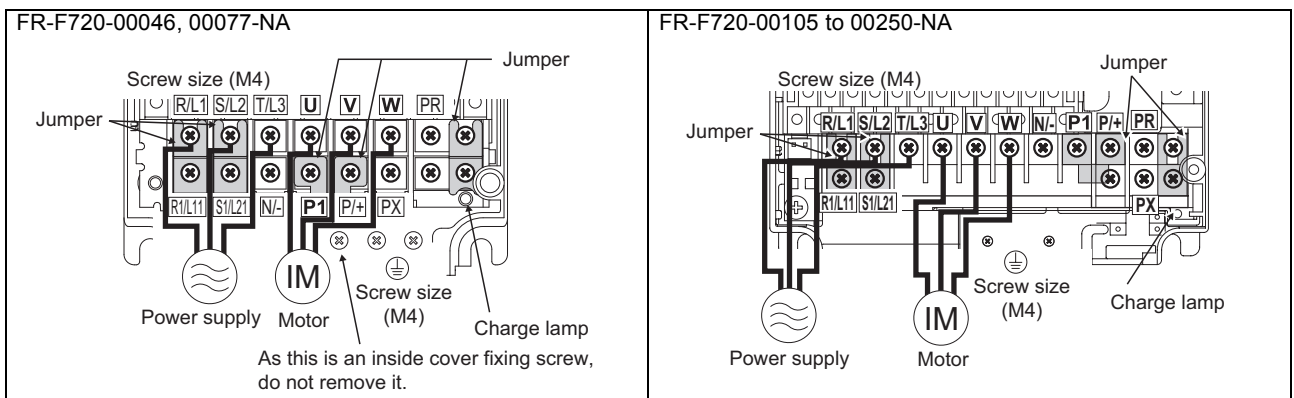

FR-F720-00340, 00490-NA

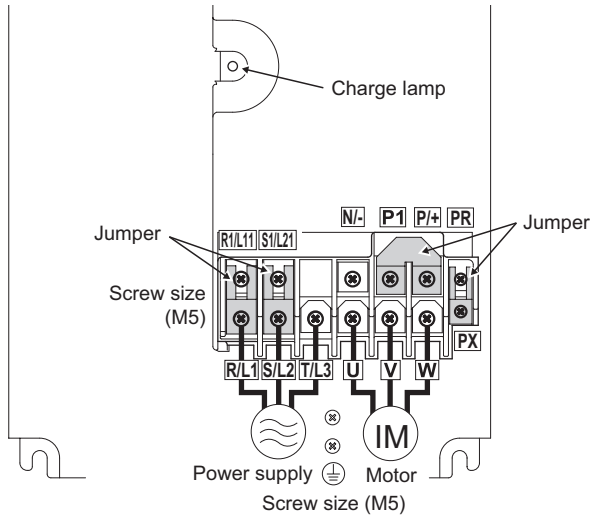

FR-F720-00630-NA

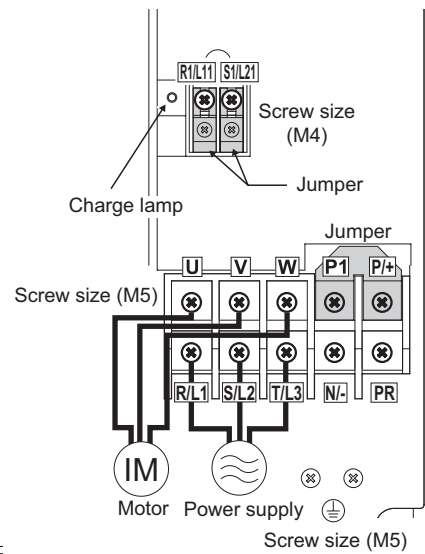

FR-F720-00770 to 01250-NA

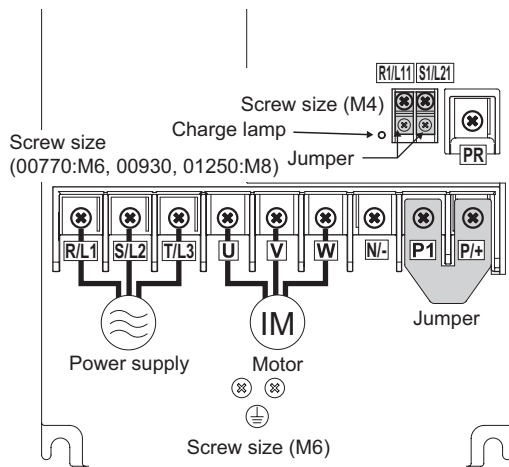

FR-F720-01540 to 02330-NA

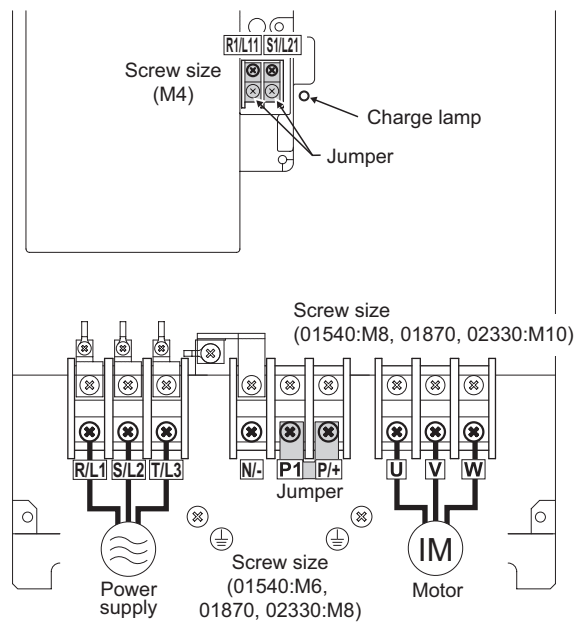

FR-F720-03160 to 04750-NA

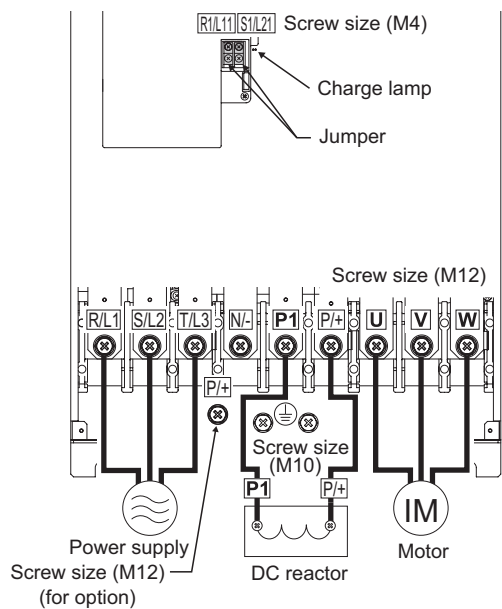



400V class

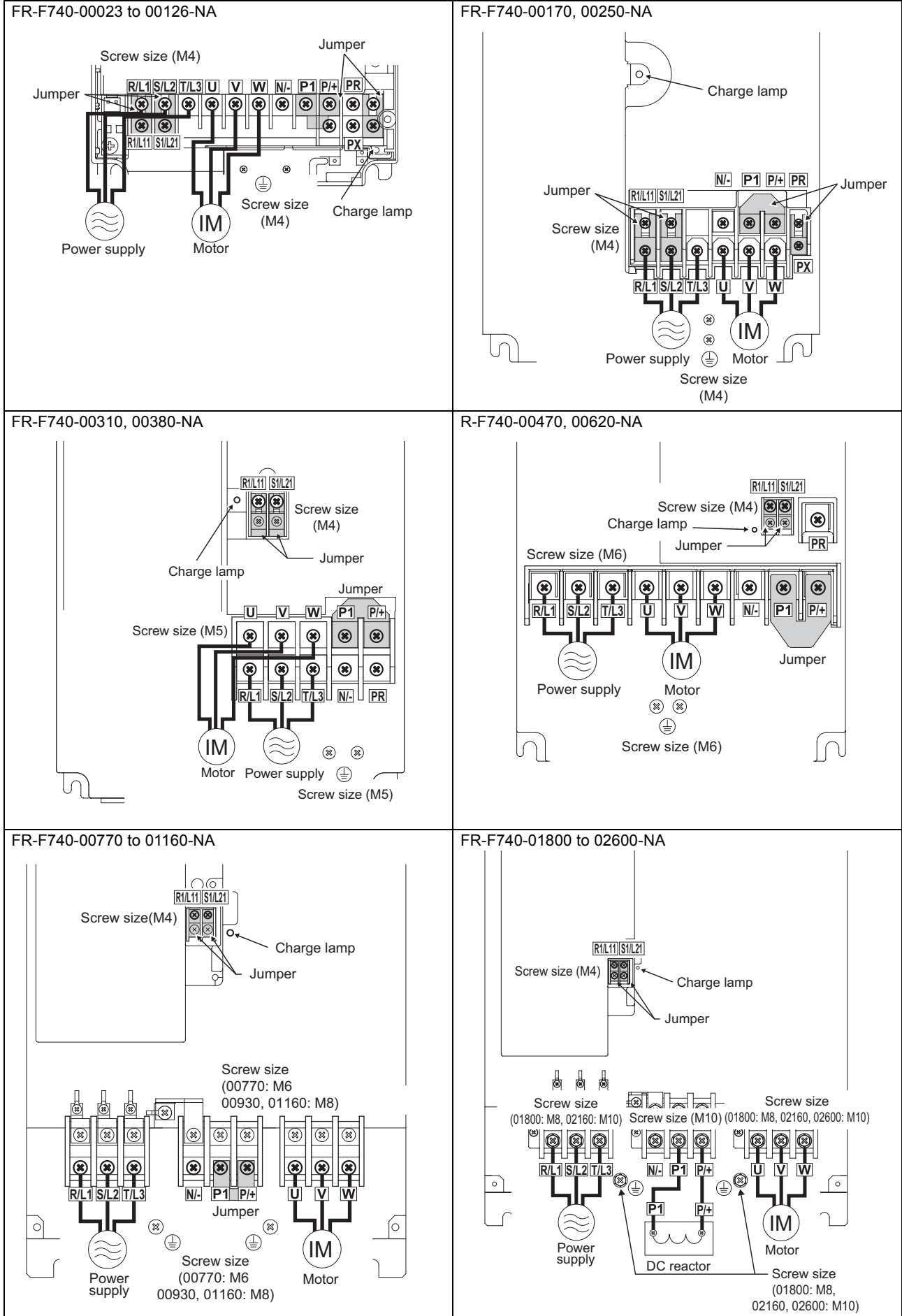

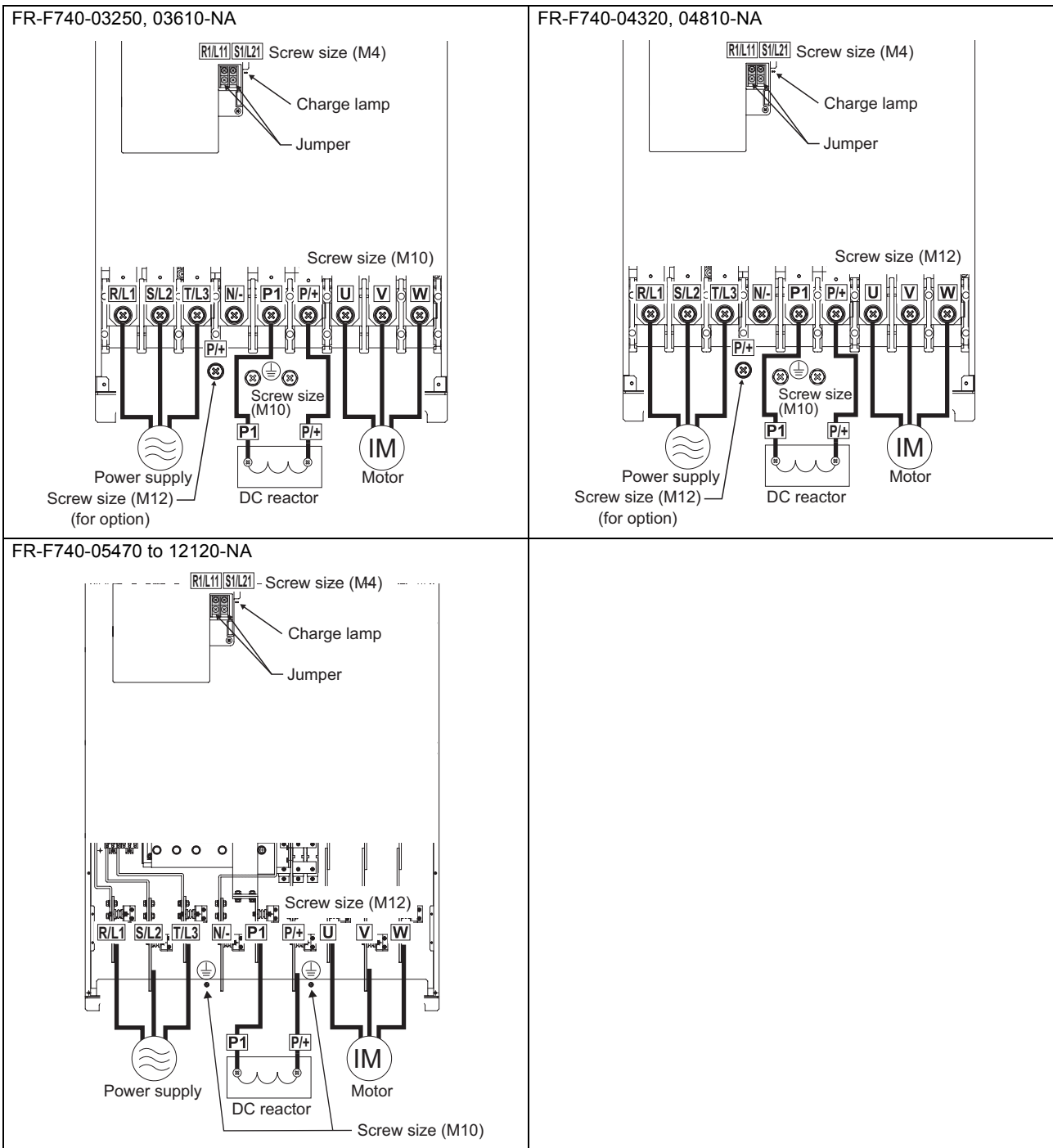
CAUTION

- The power supply cables must be connected to R/L1, S/L2, T/L3. Never connect the power cable to the U, V, W of the inverter. Doing so will damage the inverter. (Phase sequence needs not to be matched.)
- Connect the motor to U, V, W. At this time, turning on the forward rotation switch (signal) rotates the motor in the counterclockwise direction when viewed from the motor shaft.
- When wiring the inverter main circuit conductor of the FR-F740-05470 or more, tighten a nut from the right side of the conductor. When wiring two wires, place wires on both sides of the conductor. (Refer to the drawing below.) For wiring, use bolts (nuts) provided with the inverter.

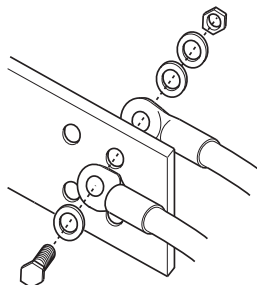



(1) Cable sizes etc., of the main control circuit terminals and ground terminals

Select the recommended cable size to ensure that a voltage drop will be 2% max.

If the wiring distance is long between the inverter and motor, a main circuit cable voltage drop will cause the motor torque to decrease especially at the output of a low frequency.

The following table indicates a selection example for the wiring length of 20m (65.62feet).

200V class (when input power supply is 220V)

Applicable Inverter Type	Terminal Screw Size *4	Tightening Torque N·m	Crimping Terminal		Cable Sizes							
					HIV, etc. (mm ²) *1			AWG *2		PVC, etc. (mm ²) *3		
			R/L1, S/L2, T/L3	U, V, W	R/L1, S/L2, T/L3	U, V, W	Ground Cable	R/L1, S/L2, T/L3	U, V, W	R/L1, S/L2, T/L3	U, V, W	Ground Cable
FR-F720-00046 to 00105-NA	M4	1.5	2-4	2-4	2	2	2	14	14	2.5	2.5	2.5
FR-F720-00167-NA	M4	1.5	5.5-4	5.5-4	3.5	3.5	3.5	12	12	4	4	4
FR-F720-00250-NA	M4	1.5	5.5-4	5.5-4	5.5	5.5	5.5	10	10	6	6	6
FR-F720-00340-NA	M5	2.5	14-5	8-5	14	8	14	6	8	16	10	16
FR-F720-00490-NA	M5	2.5	14-5	14-5	14	14	14	6	6	16	16	16
FR-F720-00630-NA	M5	2.5	22-5	22-5	22	22	14	4	6 (*5)	25	25	16
FR-F720-00770-NA	M6	4.4	38-6	38-6	38	38	22	2	2	50	50	25
FR-F720-00930-NA	M8/M6	7.8	38-8	38-8	38	38	22	2	2	50	50	25
FR-F720-01250-NA	M8/M6	7.8	60-8	60-8	60	60	38	1/0	1/0	50	50	25
FR-F720-01540-NA	M8/M6	7.8	80-8	80-8	80	80	38	3/0	3/0	70	70	35
FR-F720-01870-NA	M10/M8	14.7	100-10	100-10	100	100	60	4/0	4/0	95	95	50
FR-F720-02330-NA	M10/M8	14.7	100-10	100-10	100	100	60	4/0	4/0	95	95	50
FR-F720-03160-NA	M12	24.5	150-12	150-12	125	125	38	MCM250	MCM250	—	—	—
FR-F720-03800-NA	M12	24.5	150-12	150-12	150	150	38	2×4/0	2×4/0	—	—	—
FR-F720-04750-NA	M12	24.5	100-12	100-12	2×100	2×100	38	2×4/0	2×4/0	—	—	—

*1 The recommended cable size is that of the cable (e.g. HIV cable (600V class 2 vinyl-insulated cable)) with continuous maximum permissible temperature of 75°C (167°F). Assumes that the ambient temperature is 50°C (122°F) or less and the wiring distance is 20m (65.62feet) or less.

*2 The recommended cable size is that of the cable (THHW cable) with continuous maximum permissible temperature of 75°C (167°F). Assumes that the ambient temperature is 40°C (104°F) or less and the wiring distance is 20m (65.62feet) or less.

*3 For the FR-F720-00930 or less, the recommended cable size is that of the cable (PVC cable) with continuous maximum permissible temperature of 70°C (158°F). Assumes that the ambient temperature is 40°C (104°F) or less and the wiring distance is 20m(65.62feet) or less.

For the FR-F720-01250 or more, the recommended cable size is that of the cable (XLPE cable) with continuous maximum permissible temperature of 90°C (194°F). Assumes that the ambient temperature is 40°C (104°F) or less and wiring is performed in an enclosure.

*4 The terminal screw size indicates the terminal size for R/L1, S/L2, T/L3, U, V, W, and a screw for grounding. For the FR-F720-00930 to 02330, screw sizes are different. (R/L1, S/L2, T/L3, U, V, W, and a screw for grounding)

*5 When connecting the option unit to P/+, P1, N/-, use THHN cables for the option and terminals R/L1, S/L2, T/L3, U, V, W.

**400V class (when input power supply is 440V based on the rated current for 110% overload for 1 minute)**

Applicable Inverter Type	Terminal Screw Size *4	Tightening Torque N·m	Crimping (Compression) Terminal		Cable Sizes							
					HIV, etc. (mm ²) *1			AWG *2		PVC, etc. (mm ²) *3		
			R/L1, S/L2, T/L3	U, V, W	R/L1, S/L2, T/L3	U, V, W	Ground Cable	R/L1, S/L2, T/L3	U, V, W	R/L1, S/L2, T/L3	U, V, W	Ground Cable
FR-F740-00023 to 00083-NA	M4	1.5	2-4	2-4	2	2	2	14	14	2.5	2.5	2.5
FR-F740-00126-NA	M4	1.5	2-4	2-4	2	2	3.5	12	14	2.5	2.5	4
FR-F740-00170-NA	M4	1.5	5.5-4	5.5-4	3.5	3.5	3.5	12	12	4	4	4
FR-F740-00250-NA	M4	1.5	5.5-4	5.5-4	5.5	5.5	8	10	10	6	6	10
FR-F740-00310-NA	M5	2.5	8-5	8-5	8	8	8	8	8	10	10	10
FR-F740-00380-NA	M5	2.5	14-5	8-5	14	8	14	6	8	16	10	16
FR-F740-00470-NA	M6	4.4	14-6	14-6	14	14	14	6	6	16	16	16
FR-F740-00620-NA	M6	4.4	22-6	22-6	22	22	14	4	4	25	25	16
FR-F740-00770-NA	M6	4.4	22-6	22-6	22	22	14	4	4	25	25	16
FR-F740-00930-NA	M8	7.8	38-8	38-8	38	38	22	1	2	50	50	25
FR-F740-01160-NA	M8	7.8	60-8	60-8	60	60	22	1/0	1/0	50	50	25
FR-F740-01800-NA	M8	7.8	60-8	60-8	60	60	38	1/0	1/0	50	50	25
FR-F740-02160-NA	M10	14.7	100-10	100-10	80	80	38	3/0	3/0	70	70	35
FR-F740-02600-NA	M10	14.7	100-10	150-10	100	125	38	4/0	4/0	95	95	50
FR-F740-03250-NA	M10	14.7	150-10	150-10	125	125	38	MCM250	MCM250	120	120	70
FR-F740-03610-NA	M10	14.7	150-10	150-10	150	150	38	MCM300	MCM300	150	150	95
FR-F740-04320-NA	M12/M10	24.5	100-12	100-12	2×100	2×100	38	2×4/0	2×4/0	2×95	2×95	95
FR-F740-04810-NA	M12/M10	24.5	100-12	100-12	2×100	2×100	38	2×4/0	2×4/0	2×95	2×95	95
FR-F740-05470-NA	M12/M10	24.5	150-12	150-12	2×125	2×125	38	2×250	2×250	2×120	2×120	120
FR-F740-06100-NA	M12/M10	24.5	150-12	150-12	2×150	2×150	38	2×300	2×300	2×150	2×150	150
FR-F740-06830-NA	M12/M10	24.5	200-12	200-12	2×200	2×200	60	2×350	2×350	2×185	2×185	2×95
FR-F740-07700-NA	M12/M10	24.5	C2-200	C2-200	2×200	2×200	60	2×400	2×400	2×185	2×185	2×95
FR-F740-08660-NA	M12/M10	24.5	C2-250	C2-250	2×250	2×250	60	2×500	2×500	2×240	2×240	2×120
FR-F740-09620-NA	M12/M10	24.5	C2-250	C2-250	2×250	2×250	100	2×500	2×500	2×240	2×240	2×120
FR-F740-10940-NA	M12/M10	24.5	C2-200	C2-200	3×200	3×200	100	3×350	3×350	3×185	3×185	2×150
FR-F740-12120-NA	M12/M10	24.5	C2-200	C2-200	3×200	3×200	100	3×400	3×400	3×185	3×185	2×150

*1 For the FR-F740-01160 or less, the recommended cable size is that of the cable (e.g. HIV cable (600V class 2 vinyl-insulated cable)) with continuous maximum permissible temperature of 75°C (167°F). Assumes that the ambient temperature is 50°C (122°F) or less and the wiring distance is 20m (65.62feet) or less.

For the FR-F740-01800 or more, the recommended cable size is that of the cable (e.g. LMFC (heat resistant flexible cross-linked polyethylene insulated cable)) with continuous maximum permissible temperature of 90°C (194°F). Assumes that the ambient temperature is 50°C (122°F) or less and wiring is performed in an enclosure.

*2 For the FR-F740-00930 or less, the recommended cable size is that of the cable (THHW cable) with continuous maximum permissible temperature of 75°C (167°F). Assumes that the ambient temperature is 40°C (104°F) or less and the wiring distance is 20m (65.62feet) or less.

For the FR-F740-01160 or more, the recommended cable size is that of the cable (THHN cable) with continuous maximum permissible temperature of 90°C (194°F). Assumes that the ambient temperature is 40°C (104°F) or less and wiring is performed in an enclosure.

*3 For the FR-F740-00930 or less, the recommended cable size is that of the cable (PVC cable) with continuous maximum permissible temperature of 70°C (158°F). Assumes that the ambient temperature is 40°C (104°F) or less and the wiring distance is 20m (65.62feet) or less.

For the FR-F740-01160 or more, the recommended cable size is that of the cable (XLPE cable) with continuous maximum permissible temperature of 90°C (194°F). Assumes that the ambient temperature is 40°C (104°F) or less and wiring is performed in an enclosure.

*4 The terminal screw size indicates the terminal size for R/L1, S/L2, T/L3, U, V, W, and a screw for grounding.

For the FR-F740-04320 or more, screw sizes are different. (R/L1, S/L2, T/L3, U, V, W, and a screw for grounding)

The line voltage drop can be calculated by the following formula:

$$\text{line voltage drop [V]} = \frac{\sqrt{3} \times \text{wire resistance [m}\Omega\text{/m]} \times \text{wiring distance [m]} \times \text{current [A]}}{1000}$$

Use a larger diameter cable when the wiring distance is long or when it is desired to decrease the voltage drop (torque reduction) in the low speed range.

CAUTION

- Tighten the terminal screw to the specified torque.
A screw that has been tighten too loosely can cause a short circuit or malfunction.
A screw that has been tighten too tightly can cause a short circuit or malfunction due to the unit breakage.
- Use crimping terminals with insulation sleeve to wire the power supply and motor.



(2) Notes on

- Leakage currents flow in the inverter. To prevent an electric shock, the inverter and motor must be . This inverter must be . must conform to the requirements of national and local safety regulations and electrical codes. (JIS, NEC section 250, IEC 536 class 1 and other applicable standards)
- Use the dedicated terminal to the inverter.
(Do not use the screw in the casing, chassis, etc.)
- Use the thickest possible cable. Use the cable whose size is equal to or greater than that indicated in the above table, and minimize the cable length. The point should be as near as possible to the inverter.



To be compliant with the European Directive (Low Voltage Directive), the inverter according to the instructions on page 133.

(3) Total wiring length

The overall wiring length for connection of a single motor or multiple motors should be within the value in the table below.

<i>Pr. 72 PWM frequency selection setting (carrier frequency)</i>	FR-F720-00046 FR-F740-00023	FR-F720-00077 FR-F740-00038	FR-F720-00105 or more FR-F740-00052 or more
2 (2kHz) or less	300m (984.25 feet)	500m (1640.42 feet)	500m (1640.42 feet)
3 to 15 (3kHz to 14.5kHz) *	200m (656.19 feet)	300m (984.25 feet)	500m (1640.42 feet)

* For the FR-F720-03160 (FR-F740-01800) or more, the setting range of *Pr. 72 PWM frequency selection* is "0 to 6".

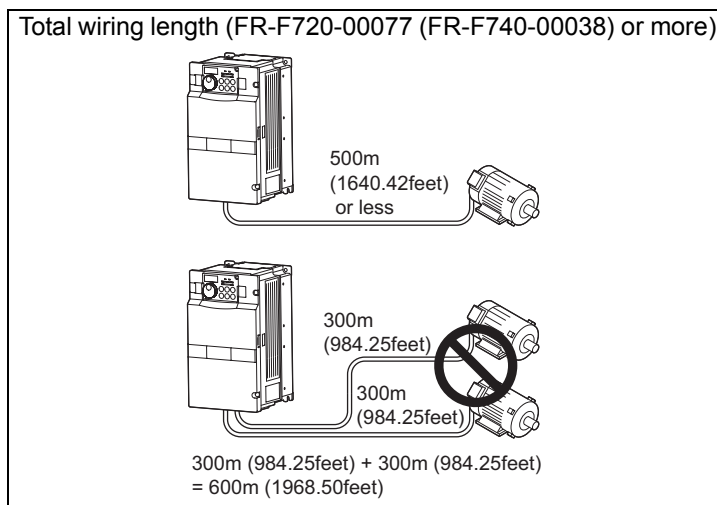

When driving a 400V class motor by the inverter, surge voltages attributable to the wiring constants may occur at the motor terminals, deteriorating the insulation of the motor. Take the following measures (1) or (2) in this case.

- (1) Use a "400V class inverter-driven insulation-enhanced motor" and set frequency in *Pr. 72 PWM frequency selection* according to wiring length

	Wiring Length		
	50m (164.04feet) or less	50m (164.04feet) to 100m (328.08feet)	exceeding 100m (328.08feet)
<i>Pr. 72 PWM frequency selection setting (carrier frequency)</i>	14.5kHz or less	9kHz or less	4kHz or less

- (2) Connect the surge voltage suppression filter (FR-ASF-H) to the FR-F720-02330 (FR-F740-01160) or less and the sine wave filter (MT-BSL/BSC) to the FR-F720-03160 (FR-F740-01800) or more on the inverter output side.

CAUTION

- Especially for long-distance wiring, the inverter may be affected by a charging current caused by the stray capacitances of the wiring, leading to a malfunction of the overcurrent protective function or fast response current limit function or a malfunction or fault of the equipment connected on the inverter output side. If fast-response current limit function malfunctions, disable this function. (For *Pr.156 Stall prevention operation selection*, refer to the *Instruction Manual (applied)*.)
- For details of *Pr. 72 PWM frequency selection*, refer to the *Instruction Manual (applied)*.
For explanation of surge voltage suppression filter (FR-ASF-H) and sine wave filter (MT-BSL/BSC), refer to the manual of each option.

(4) Cable size of the control circuit power supply (terminal R1/L11, S1/L21)

- Terminal Screw Size: M4
- Cable size: 0.75mm² to 2mm²
- Tightening torque: 1.5N·m

2.4.4 Control circuit terminals

indicates that terminal functions can be selected from Pr. 178 to Pr. 196 (I/O terminal function selection) (Refer to the Instruction Manual (applied).)

(1) Input signals

Type	Terminal Symbol	Terminal Name	Description		Rated Specifications	Refer to
Contact input	STF	Forward rotation start	Turn on the STF signal to start forward rotation and turn it off to stop.	When the STF and STR signals are turned on simultaneously, the stop command is given.	Input resistance 4.7kΩ Voltage at opening: 21 to 27VDC Contacts at short-circuited: 4 to 6mADC	43
	STR	Reverse rotation start	Turn on the STR signal to start reverse rotation and turn it off to stop.			
	STOP	Start self-holding selection	Turn on the STOP signal to self-hold the start signal.			Instruction Manual (applied)
	RH, RM, RL	Multi-speed selection	Multi-speed can be selected according to the combination of RH, RM and RL signals.			45
	JOG	Jog mode selection	Turn on the JOG signal to select Jog operation (initial setting) and turn on the start signal (STF or STR) to start Jog operation.			Instruction Manual (applied)
	RT	Second acceleration/ deceleration time selection	Turn on the RT signal to select second acceleration/ deceleration time. When the second function such as "second torque boost" and "second V/F (base frequency)" are set, turning on the RT signal selects these functions.			Instruction Manual (applied)
	MRS	Output stop	Turn on the MRS signal (20ms or more) to stop the inverter output. Use to shut off the inverter output when stopping the motor by electromagnetic brake.			Instruction Manual (applied)
	RES	Reset	Used to reset alarm output provided when protective function is activated. Turn on the RES signal for more than 0.1s, then turn it off. Initial setting is for reset always. By setting Pr.75, reset can be set to enabled only at an inverter alarm occurrence. Recover about 1s after reset is cancelled.			75
	AU	Terminal 4 input selection	Terminal 4 is made valid only when the AU signal is turned on. (The frequency setting signal can be set between 4 and 20mADC.) Turning the AU signal on makes terminal 2 (voltage input) invalid.			49
		PTC input	AU terminal is used as PTC input terminal (thermal protection of the motor). When using it as PTC input terminal, set the AU/ PTC switch to PTC.			Instruction Manual (applied)
CS	Selection of automatic restart after instantaneous power failure	When the CS signal is left on, the inverter restarts automatically at power restoration. Note that restart setting is necessary for this operation. In the initial setting, a restart is disabled. (Refer to Pr.57 Restart coasting time in Instruction Manual (applied).)		Instruction Manual (applied)		
SD	Contact input common (sink)	Common terminal for contact input terminal (sink logic). Common output terminal for 24VDC 0.1A power supply (PC terminal). Isolated from terminals 5 and SE.		—	—	
PC	External transistor common, 24VDC power supply, contact input common (source)	When connecting the transistor output (open collector output), such as a programmable controller (PLC), when sink logic is selected, connect the external power supply common for transistor output to this terminal to prevent a malfunction caused by undesirable currents. Can be used as 24VDC 0.1A power supply. When source logic has been selected, this terminal serves as a contact input common.		Power supply voltage range 19.2 to 28.8VDC Current consumption 100mA	23	



Type	Terminal Symbol	Terminal Name	Description	Rated Specifications	Refer to
Frequency setting	10E	Frequency setting power supply	When connecting the frequency setting potentiometer at an initial status, connect it to terminal 10. Change the input specifications when connecting it to terminal 10E. (Refer to Pr.73 Analog input selection in the Instruction Manual (applied).)	10VDC Permissible load current 10mA	Instruction Manual (applied)
	10			5VDC Permissible load current 10mA	39, 47
	2	Frequency setting (voltage)	Inputting 0 to 5VDC (or 0 to 10V, 4 to 20mA) provides the maximum output frequency at 5V (10V, 20mA) and makes input and output proportional. Use Pr.73 to switch from among input 0 to 5VDC (initial setting), 0 to 10VDC, and 0 to 20mA.	Voltage input: Input resistance 10kΩ ± 1kΩ Maximum permissible voltage 20VDC Current input: Input resistance 250Ω ± 2% Maximum permissible current 30mA	39, 47
	4	Frequency setting (current)	Inputting 4 to 20mADC (or 0 to 5V, 0 to 10V) provides the maximum output frequency at 20mA (5V, 10V) makes input and output proportional. This input signal is valid only when the AU signal is on (terminal 2 input is invalid). Use Pr.267 to switch between the input 4 to 20mA and 0 to 5VDC, 0 to 10VDC (initial setting). (Refer to the Instruction Manual (applied).)		41, 49
	1	Frequency setting auxiliary	Inputting 0 to ±5 VDC or 0 to ±10VDC adds this signal to terminal 2 or 4 frequency setting signal. Use Pr.73 to switch between the input 0 to ±5VDC and 0 to ±10VDC (initial setting).	Input resistance 10kΩ ± 1kΩ Maximum permissible voltage ± 20VDC	Instruction Manual (applied)
	5	Frequency setting common	Common terminal for frequency setting signal (terminal 2, 1 or 4) and analog output terminal AM and CA. Do not ground.	—	—

(2) Output signals

Type	Terminal Symbol	Terminal Name	Description	Rated Specifications	Refer to
Relay	A1, B1, C1	Relay output 1 (alarm output)	1 changeover contact output indicates that the inverter protective function has activated and the output stopped. Abnormal: No conduction across B-C (Across A-C Continuity), Normal: Across B-C Continuity (No conduction across A-C)	Contact capacity: 230VAC 0.3A (Power factor=0.4) 30VDC 0.3A	Instruction Manual (applied)
	A2, B2, C2	Relay output 2	1 changeover Contact output		Instruction Manual (applied)
Open collector	RUN	Inverter running	Switched low when the inverter output frequency is equal to or higher than the starting frequency (initial value 0.5Hz). Switched high during stop or DC injection brake operation. *1	Alarm code (4bit) output (Refer to the Instruction Manual (applied).) Permissible load 24VDC 0.1A (A voltage drop is 3.4V maximum when the signal is on.)	Instruction Manual (applied)
	SU	Up to frequency	Switched low when the output frequency reaches within the range of ±10% (initial value) of the set frequency. Switched high during acceleration/deceleration and at a stop. *1		Instruction Manual (applied)
	OL	Overload alarm	Switched low when stall prevention is activated by the stall prevention function. Switched high when stall prevention is cancelled. *1		Instruction Manual (applied)
	IPF	Instantaneous power failure	Switched low when an instantaneous power failure and under voltage protections are activated. *1		Instruction Manual (applied)
	FU	Frequency detection	Switched low when the inverter output frequency is equal to or higher than the preset detected frequency and high when less than the preset detected frequency. *1		Instruction Manual (applied)
	SE	Open collector output common	Common terminal for terminals RUN, SU, OL, IPF, FU	—	—

Type	Terminal Symbol	Terminal Name	Description	Rated Specifications	Refer to	
Analog	CA	Analog current output	Select one e.g. output frequency from monitor items. *2 The output signal is proportional to the magnitude of the corresponding monitoring item.	Output item: Output frequency (initial setting)	Load impedance 200Ω to 450Ω Output signal 0 to 20mADC	Instruction Manual (applied)
	AM	Analog voltage output				Output signal 0 to 10VDC Permissible load current 1mA (load impedance 10kΩ or more) Resolution 8 bit

*1 Low indicates that the open collector output transistor is on (conducts).
High indicates that the transistor is off (does not conduct).

*2 Not output during inverter reset.

(3) Communication

Type	Terminal Symbol	Terminal Name	Description	Refer to	
RS-485	PU connector	PU connector	With the PU connector, communication can be made through RS-485. (for connection on a 1:1 basis only) . Conforming standard : EIA-485(RS-485) . Transmission format : Multidrop . Communication speed : 4800 to 38400bps . Overall length : 500m (1640.42feet)	24	
	RS-485 terminals	TXD+	Inverter transmission terminal	With the RS-485 terminals, communication can be made through RS-485. Conforming standard : EIA-485(RS-485) Transmission format : Multidrop link Communication speed : 300 to 38400bps Overall length : 500m (1640.42feet)	25
		TXD-			
		RXD+	Inverter reception terminal		
		RXD-			
SG	Ground				

(4) Control circuit terminal layout

Terminal screw size: M3.5
Tightening torque: 1.2N·m

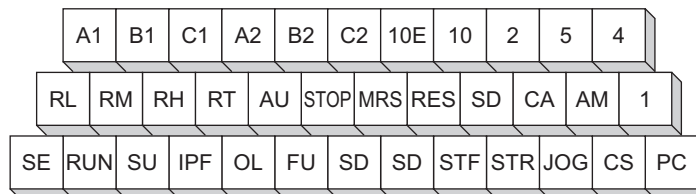

Avoid connecting the terminal SD and 5 and the terminal SE and 5.

(5) Wiring instructions

- Terminals 5, PC and SE are common to the I/O signals and isolated from each other. Do not ground.
- Use shielded or twisted cables for connection to the control circuit terminals and run them away from the main and power circuits (including the 200V relay sequence circuit).
- Use two or more parallel micro-signal contacts or twin contacts to prevent a contact faults when using contact inputs since the control circuit input signals are micro-currents.

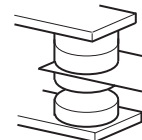

Micro signal contacts

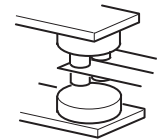

Twin contacts

- Do not apply a voltage to the contact input terminals (e.g. STF) of the control circuit.
- Always apply a voltage to the alarm output terminals (A, B, C) via a relay coil, lamp, etc.
- It is recommended to use the cables of 0.75mm² gauge for connection to the control circuit terminals.
If the cable gauge used is 1.25mm² or more, the front cover may be lifted when there are many cables running or the cables are run improperly, resulting in an operation panel contact fault.
- The wiring length should be 30m (98.43feet) maximum.



● **Wiring of the control circuit of the FR-F720-03160 (FR-F740-01800) or more**

For wiring of the control circuit of the FR-F720-03160 (FR-F740-01800) or more, separate away from wiring of the main circuit.

Make cuts in rubber bush of the inverter side and lead wires.

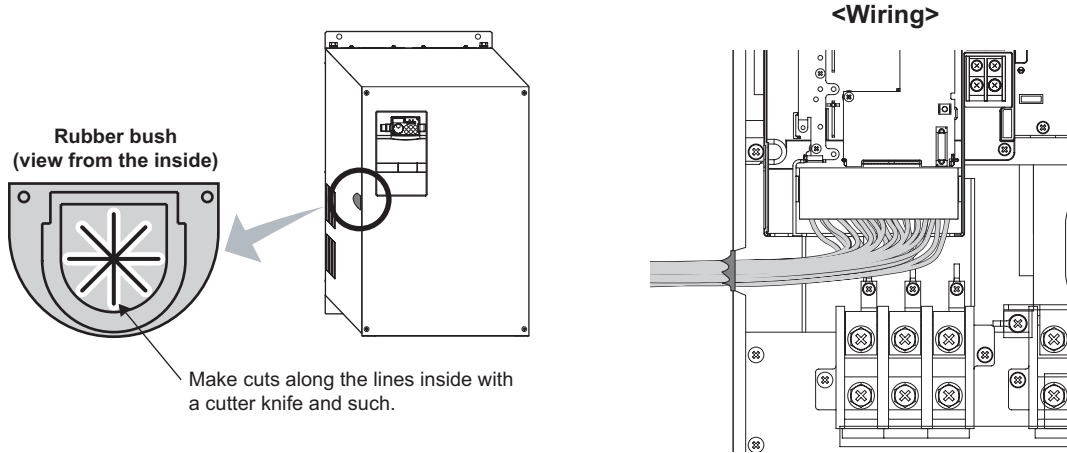

(6) When connecting the control circuit and the main circuit separately to the power supply (separate power)

<Connection diagram>

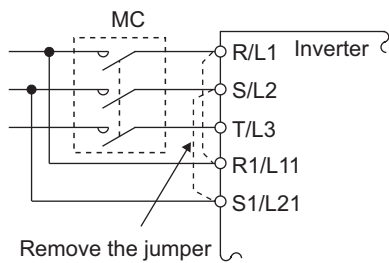

When the protected circuit is activated, opening of the electromagnetic contactor (MC) on the inverter power supply side results in power loss in the control circuit, disabling the alarm output signal retention. Terminals R1/L11 and S1/L21 are provided to hold an alarm signal. In this case, connect the power supply terminals R1/L11 and S1/L21 of the control circuit to the primary side of the MC.

● **FR-F720-00046 to 00250, FR-F740-00023 to 00126**

- 1) Loosen the upper screws.
- 2) Remove the lower screws.
- 3) Remove the jumper
- 4) Connect the separate power supply cable for the control circuit to the lower terminals (R1/L11, S1/L21).

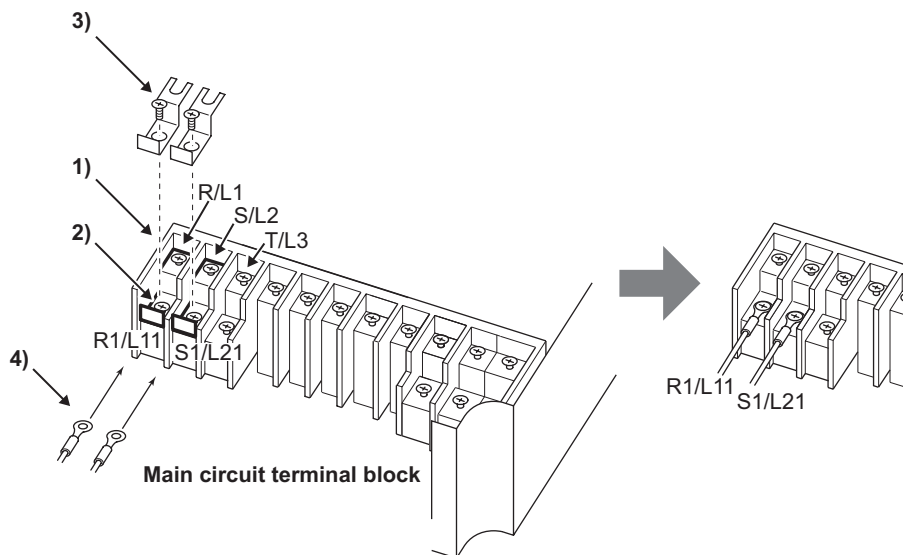

•FR-F720-00340, 00490, FR-F740-00170, 00250

- 1) Remove the upper screws.
- 2) Remove the lower screws.
- 3) Remove the jumper.
- 4) Connect the separate power supply cable for the control circuit to the upper terminals (R1/L11, S1/L21).

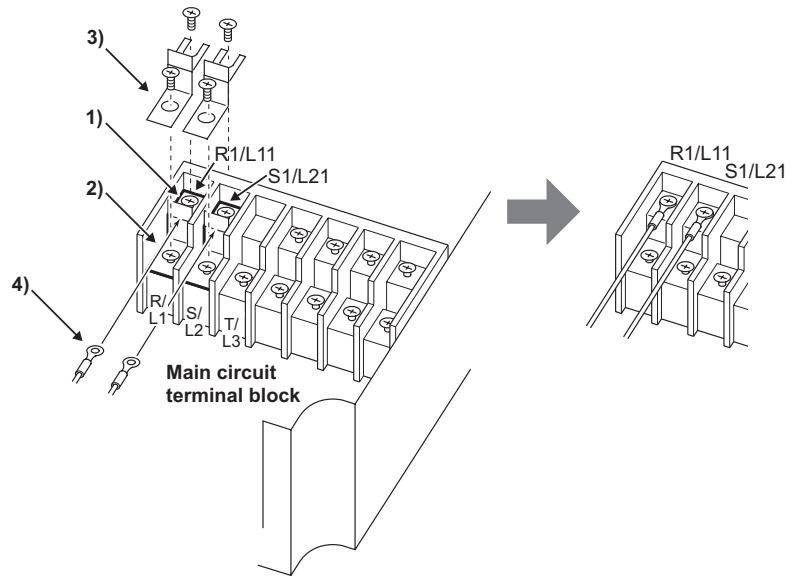
• FR-F720-00630 (FR-F740-00310) or more

- 1) Remove the upper screws.
- 2) Remove the lower screws.
- 3) Pull the jumper toward you to remove.
- 4) Connect the separate power supply cable for the control circuit to the upper terminals (R1/L11, S1/L21). **Never connect the power cable to the terminals in the lower stand. Doing so will damage the inverter.**

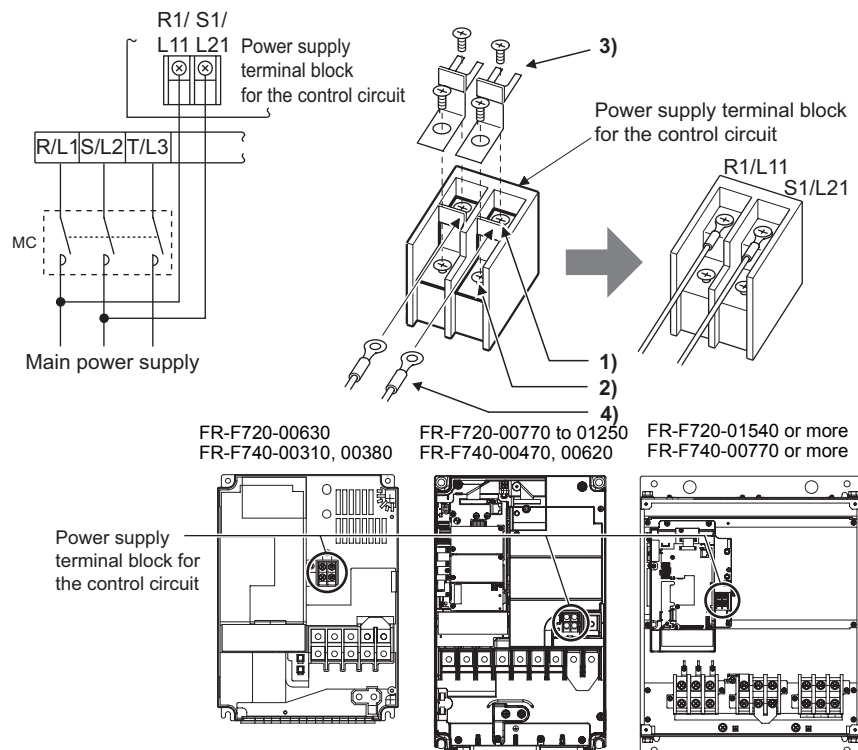
CAUTION

1. Do not turn off the control power (terminals R1/L11 and S1/L21) with the main circuit power (R/L1, S/L2, T/L3) on. Doing so may damage the inverter.
2. Be sure to use the inverter with the jumpers across terminals R/L1-R1/L11 and S/L2-S1/L21 removed when supplying power from other sources. The inverter may be damaged if you do not remove the jumper.
3. The voltage should be the same as that of the main control circuit when the control circuit power is supplied from other than the primary side of the MC.
4. The power capacity is 60VA or more for FR-F720-00770 (FR-F740-00380) or less, 80VA or more for FR-F720-00930 (FR-F740-00470) or more when separate power is supplied from R1/L11, S1/L21.
5. When the power supply used with the control circuit is different from the one used with the main circuit, make up a circuit which will switch off the main circuit power supply terminals R/L1, S/L2, T/L3 when the control circuit power supply terminals R1/L11, S1/L21 are switched off.



(7) Control logic switchover

The input signals are set to sink logic (SINK) when shipped from the factory.

To change the control logic, the jumper connector on the back of the control circuit terminal block must be moved to the other position.

(The output signals may be used in either the sink or source logic independently of the jumper connector position.)

1) Loosen the two installation screws in both ends of the control circuit terminal block. (These screws cannot be removed.)

Pull down the terminal block from behind the control circuit terminals.

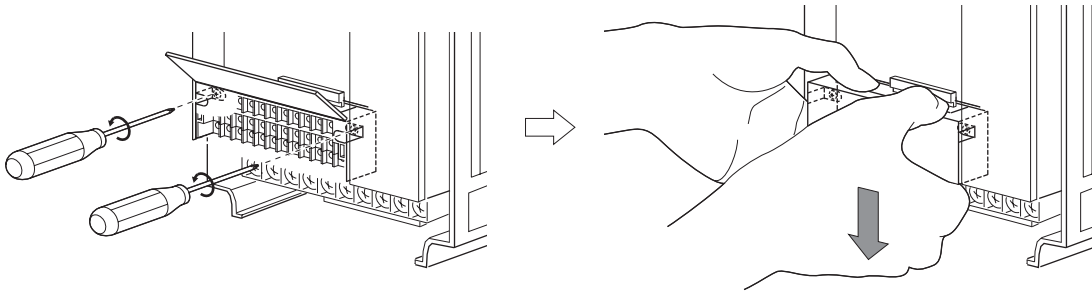

2) Change the jumper connector set to the sink logic (SINK) on the rear panel of the control circuit terminal block to source logic (SOURCE).

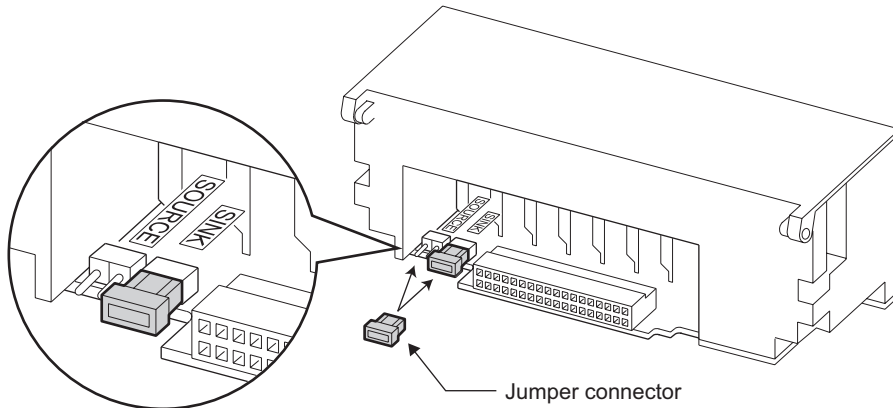

3) Using care not to bend the pins of the inverter's control circuit connector, reinstall the control circuit terminal block and fix it with the mounting screws.

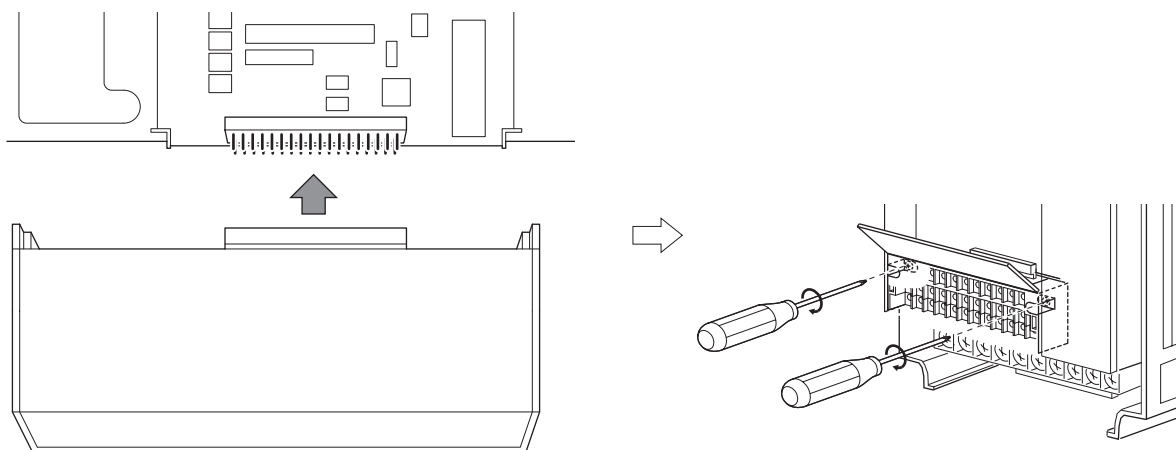

CAUTION

1. Make sure that the control circuit connector is fitted correctly.
2. While power is on, never disconnect the control circuit terminal block.

4) Sink logic and source logic

- In sink logic, a signal switches on when a current flows from the corresponding signal input terminal. Terminal SD is common to the contact input signals. Terminal SE is common to the open collector output signals.
- In source logic, a signal switches on when a current flows into the corresponding signal input terminal. Terminal PC is common to the contact input signals. Terminal SE is common to the open collector output signals.

● Current flow concerning the input/output signal when sink logic is selected

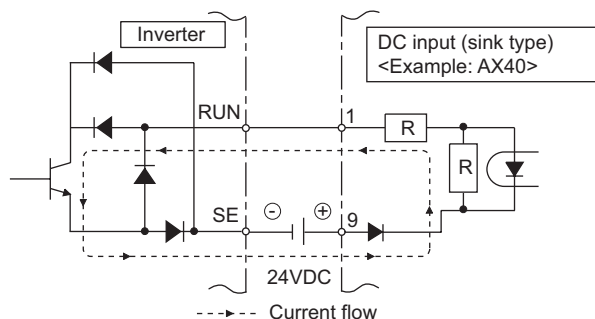
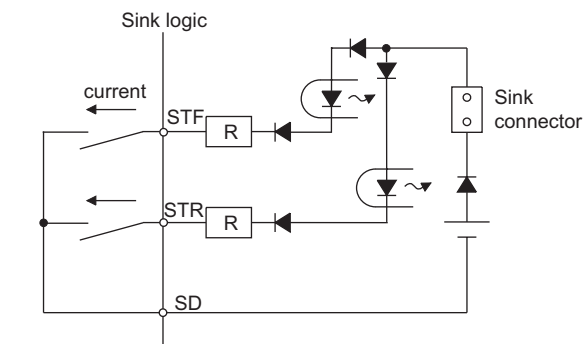

● Current flow concerning the input/output signal when source logic is selected

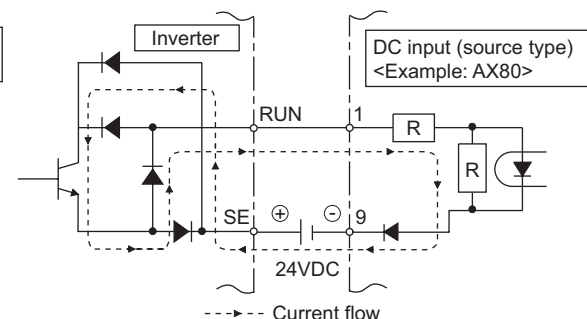
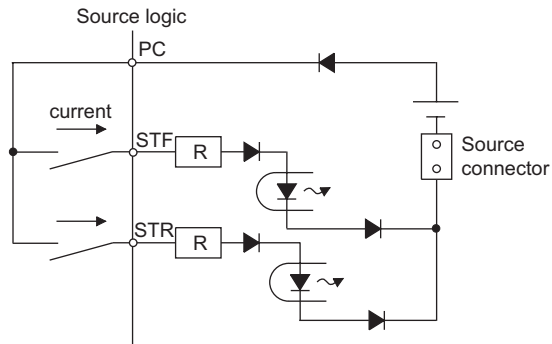

● When using an external power supply for transistor output

· Sink logic type
Use terminal PC as a common terminal to prevent a malfunction caused by undesirable current. (Do not connect terminal SD of the inverter with terminal 0V of the external power supply. When using terminals PC-SD as a 24VDC power supply, do not install a power supply in parallel in the outside of the inverter. Doing so may cause a malfunction due to undesirable current.)

· Source logic type
When using a transistor power supply for transistor output, use terminal SD as a common to prevent misoperation caused by undesirable current.



2.4.5 When connecting the operation panel using a connection cable

When connecting the operation panel (FR-DU07) to the inverter using a cable, the operation panel can be mounted on the enclosure surface and operability improves.

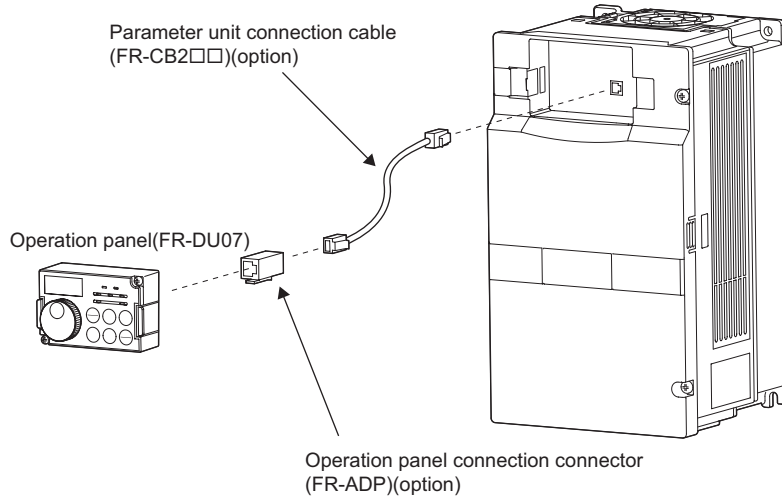

CAUTION

Do not connect the PU connector to the computer's LAN port, FAX modem socket or telephone connector. The inverter and machine could be damaged due to differences in electrical specifications.

REMARKS

- Refer to page 5 for removal method of the operation panel.
- When using a commercially available connector and cable as a parameter unit connection cable, refer to the *Instruction Manual (applied)*.
- The inverter can be connected to the computer and FR-PU04.

2.4.6 Connector with/without EMC filter

Change the connector from OFF to ON to make the EMC filter valid. (In the initial setting status, the connector is fitted to OFF.)

(If it is difficult to disconnect the connector, use a pair of long-nose pliers, etc.)

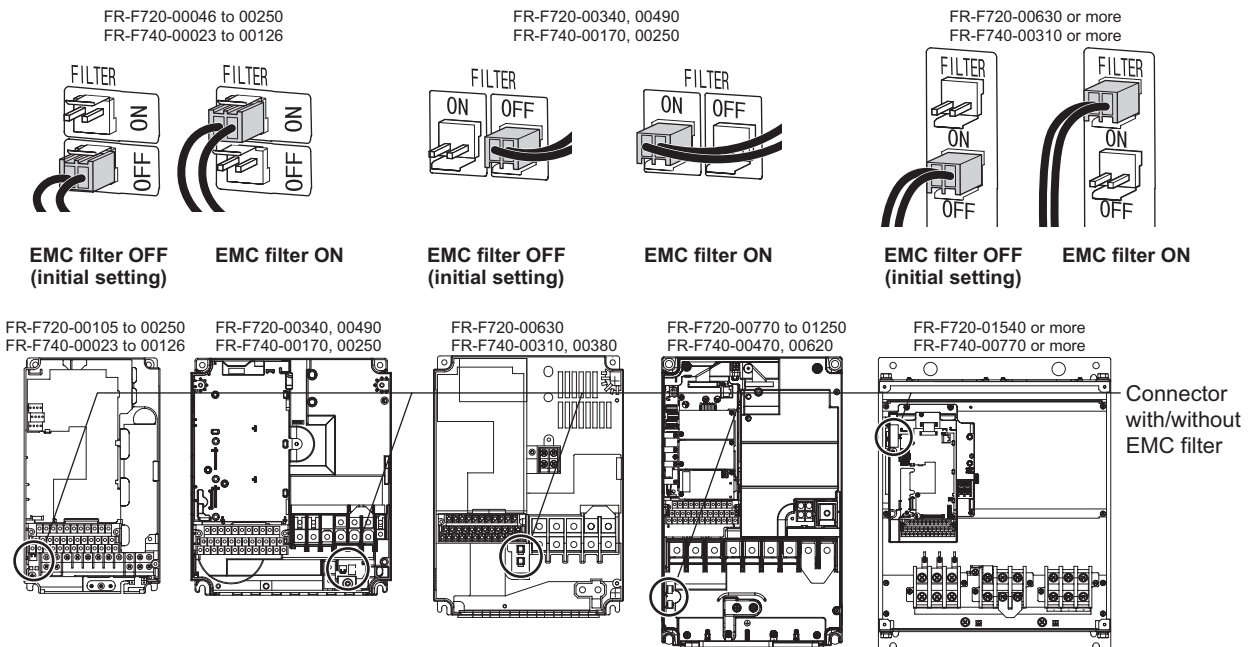

The FR-F720-00046 and 00077 are not provided with the ON/OFF connector of the EMC filter.

CAUTION

Leakage current will increase when the EMC filter is selected. For details of noise and leakage current, refer to the *Instruction Manual (applied)*.

2.4.7 RS-485 terminal block

- Conforming standard: EIA-485(RS-485)
- Transmission format: Multidrop link
- Communication speed: MAX 38400bps
- Overall length: 500m
- Connection cable: Twisted pair cable
(4 paires)

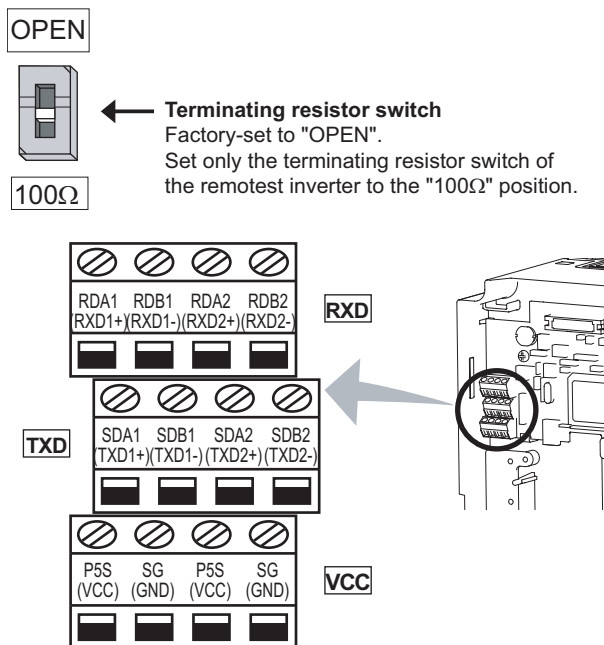

2.4.8 Communication operation

Using the PU connector or RS-485 terminal, you can perform communication operation from a personal computer etc. When the PU connector is connected with a personal, FA or other computer by a communication cable, a user program can run and monitor the inverter or read and write to parameters.

For the Mitsubishi inverter protocol (computer link operation), communication can be performed with the PU connector and RS-485 terminal.

For the Modbus RTU protocol, communication can be performed with the RS-485 terminal.

For further details, refer to the instruction manual (applied).

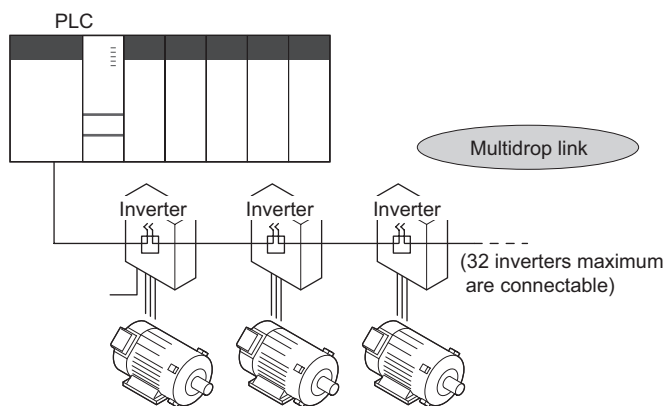

2.5 Power-off and magnetic contactor (MC)

(1) Inverter input side magnetic contactor (MC)

On the inverter input side, it is recommended to provide an MC for the following purposes.

( Refer to *page 3* for selection.)

- 1) To release the inverter from the power supply when the inverter's protective function is activated or when the drive is not functioning (e.g. emergency stop operation).
 - 2) To prevent any accident due to an automatic restart at restoration of power after an inverter stop made by a power failure
 - 3) The control power supply for inverter is always running and consumes a little power. When stopping the inverter for an extended period of time, powering off the inverter will save power slightly.
 - 4) To separate the inverter from the power supply to ensure safe maintenance and inspection work
- The inverter's input side MC is used for the above purpose, select class JEM1038-AC3MC for the inverter input side current when making an emergency stop during normal operation.

REMARKS

The MC may be switched on/off to start/stop the inverter. However, since repeated inrush currents at power on will shorten the life of the converter circuit (switching life is about 1,000,000 times.(FR-F720-01540 or more, switching life is about 500,000)), frequent starts and stops must be avoided. Turn on/off the inverter start controlling terminals (STF, STR) to run/stop the inverter.

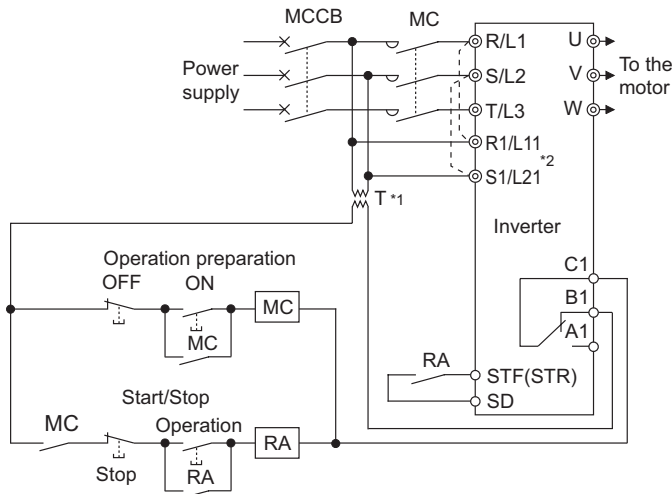

• Inverter start/stop circuit example

As shown on the left, always use the start signal (ON or OFF across terminals STF or STR-SD) to make a start or stop.

- *1 When the power supply is 400V class, install a step-down transformer.
- *2 Connect the power supply terminals R1/L11, S1/L21 of the control circuit to the primary side of the MC to hold an alarm signal when the inverter's protective circuit is activated. At this time, remove jumpers across terminals R/L1-R1/L11 and S/L2-S1/L21. (Refer to *page 20* for removal of the jumper.)

(2) Handling of the inverter output side magnetic contactor

Switch the magnetic contactor between the inverter and motor only when both the inverter and motor are at a stop. When the magnetic contactor is turned on while the inverter is operating, overcurrent protection of the inverter and such will activate. When an MC is provided to switch to a commercial power supply, for example, it is recommended to use commercial power supply-inverter switchover operation *Pr. 135 to Pr. 139* ( *Instruction Manual (applied)*).

2.6 Precautions for use of the inverter

The FR-F700 series is a highly reliable product, but incorrect peripheral circuit making or operation/handling method may shorten the product life or damage the product.

Before starting operation, always recheck the following items.

- (1) Use crimping terminals with insulation sleeve to wire the power supply and motor.
- (2) Application of power to the output terminals (U, V, W) of the inverter will damage the inverter. Never perform such wiring.
- (3) After wiring, wire offcuts must not be left in the inverter.
Wire offcuts can cause an alarm, failure or malfunction. Always keep the inverter clean. When drilling mounting holes in an enclosure etc., take care not to allow chips and other foreign matter to enter the inverter.
- (4) Use cables of the size to make a voltage drop 2% maximum.
If the wiring distance is long between the inverter and motor, a main circuit cable voltage drop will cause the motor torque to decrease especially at the output of a low frequency.
Refer to *page 14* for the recommended cable sizes.
- (5) The overall wiring length should be 500m (1640.4 feet) maximum.
Especially for long distance wiring, the fast-response current limit function may be reduced or the equipment connected to the inverter output side may malfunction or become faulty under the influence of a charging current due to the stray capacity of the wiring. Therefore, note the overall wiring length. (*Refer to page 16.*)
- (6) Electromagnetic wave interference
The input/output (main circuit) of the inverter includes high frequency components, which may interfere with the communication devices (such as AM radios) used near the inverter. In this case, set the EMC filter valid to minimize interference. (*Refer to page 24*)
- (7) Do not install a power factor correction capacitor, varistor or arrester on the inverter output side.
This will cause the inverter to trip or the capacitor, varistor, or arrester to be damaged. If any of the above devices is installed, immediately remove it.
- (8) Before starting wiring or other work after the inverter is operated, wait for at least 10 minutes after the power supply has been switched off, and check that there are no residual voltage using a tester or the like. The capacitor is charged with high voltage for some time after power off and it is dangerous.
- (9) A short circuit or ground fault on the inverter output side may damage the inverter modules.
 - Fully check the insulation resistance of the circuit prior to inverter operation since repeated short circuits caused by peripheral circuit inadequacy or a ground fault caused by wiring inadequacy or reduced motor insulation resistance may damage the inverter modules.
 - Fully check the to-ground insulation and inter-phase insulation of the inverter output side before power-on.
Especially for an old motor or use in hostile atmosphere, securely check the motor insulation resistance etc.
- (10) Do not use the inverter input side magnetic contactor to start/stop the inverter.
Always use the start signal (ON/OFF of STF and STR signals) to start/stop the inverter. (*Refer to page 9*)
- (11) Do not apply a voltage higher than the permissible voltage to the inverter I/O signal circuits.
Contact to the inverter I/O signal circuits or opposite polarity may damage the I/O devices. Especially check the wiring to prevent the speed setting potentiometer from being connected incorrectly to short terminals 10E-5.
- (12) Provide electrical and mechanical interlocks for MC1 and MC2 which are used for commercial power supply-inverter switch-over.
When the wiring is incorrect or if there is a commercial power supply-inverter switch-over circuit as shown below, the inverter will be damaged by leakage current from the power supply due to arcs generated at the time of switch-over or chattering caused by a sequence error.

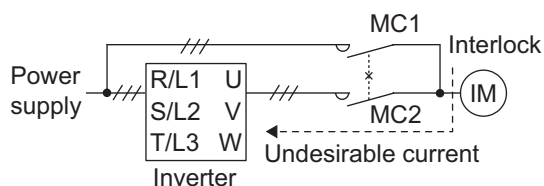

- (13) If the machine must not be restarted when power is restored after a power failure, provide a magnetic contactor in the inverter's input side and also make up a sequence which will not switch on the start signal.
If the start signal (start switch) remains on after a power failure, the inverter will automatically restart as soon as the power is restored.
- (14) Instructions for overload operation
When performing operation of frequent start/stop of the inverter, increase/decrease in the temperature of the transistor element of the inverter may repeat due to a continuous flow of large current, shortening the life from thermal fatigue. Since thermal fatigue is related to the amount of current, the life can be increased by reducing bound current, starting current, etc. Decreasing current may increase the life. However, decreasing current will result in insufficient torque and the inverter may not start. Therefore, increase the inverter capacity to have enough allowance for current.
- (15) Make sure that the specifications and rating match the system requirements.

3 DRIVE THE MOTOR

3.1 Step of operation

The inverter needs frequency command and start command.

Refer to the flow chart below to perform setting.

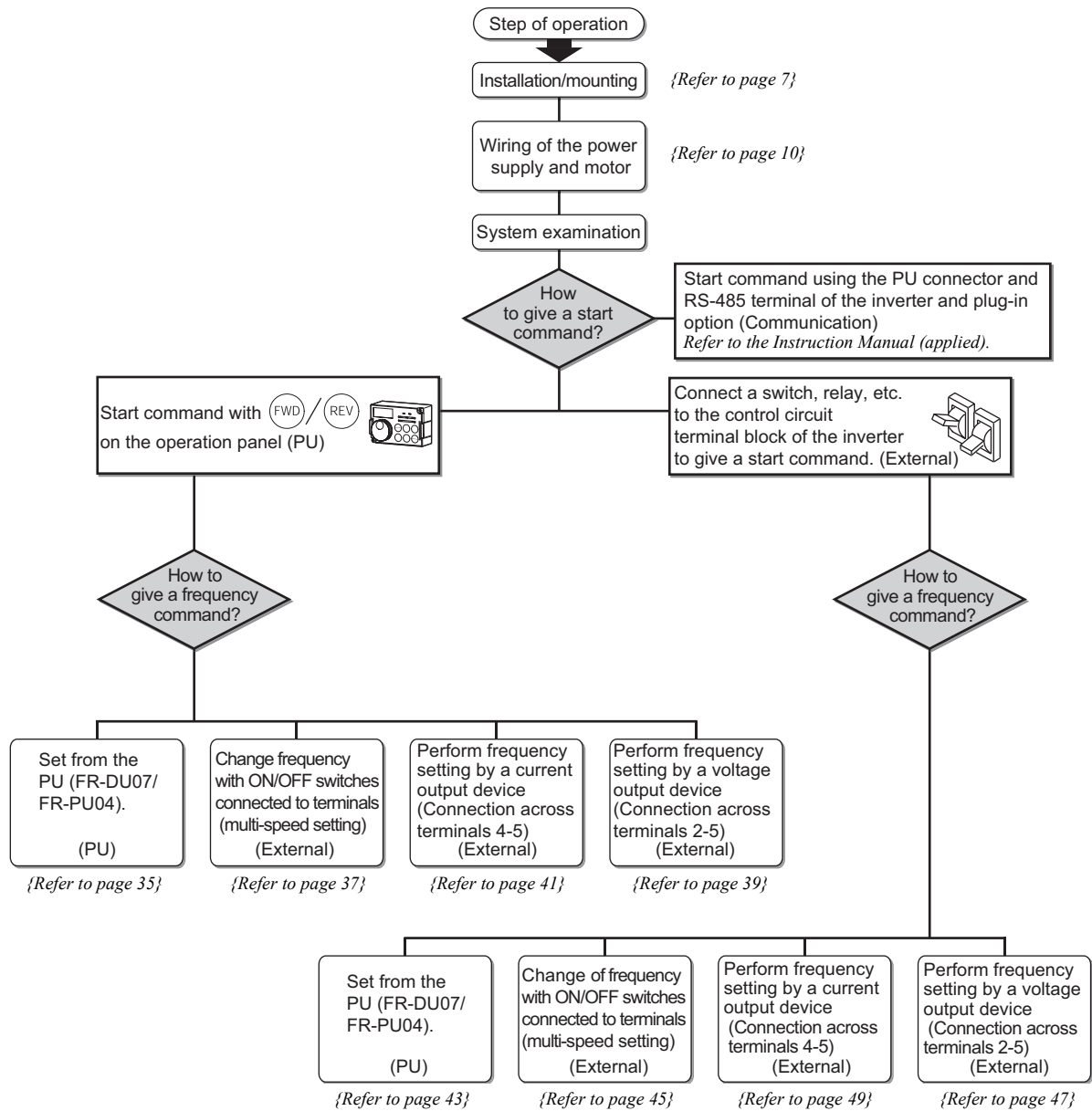

CAUTION

Check the following items before powering on the inverter.

- Check that the inverter is installed correctly in a correct place. (Refer to page 7)
- Check that wiring is correct. (Refer to page 9)
- Check that no load is connected to the motor.



- When protecting the motor from overheat by the inverter, set Pr.9 Electronic thermal O/L relay (Refer to page 33)
- When the rated frequency of the motor is 50Hz, set Pr.3 Base frequency (Refer to page 34)



3.2 Operation panel (FR-DU07)

3.2.1 Parts of the operation panel (FR-DU07)

Operation mode indication
 PU: Lit to indicate PU operation mode.
 EXT: Lit to indicate external operation mode.
 NET: Lit to indicate network operation mode.

Rotation direction indication
 FWD: Lit during forward rotation
 REV: Lit during reverse rotation
 On: Forward/reverse operation
 Flickering: When the frequency command is not given even if the forward/reverse command is given.

Unit indication
 · Hz: Lit to indicate frequency.
 · A: Lit to indicate current.
 · V: Lit to indicate voltage.
 (Flicker when the set frequency monitor is displayed.)

Monitor indication
 Lit to indicate monitoring mode.

Monitor(4-digit LED)
 Shows the frequency, parameter number, etc.

No function

Operation command forward rotation

Operation command reverse rotation

Stop operation
 Alarms can be reset

Setting dial
 (Setting dial: Mitsubishi inverter dial)
 Used to change the frequency setting and parameter values.

Mode switchover
 Used to change each setting mode.

Mode switchover
 Used to switch between the PU and external operation mode.
 When using the external operation mode (operation using a separately connected frequency setting potentiometer and start signal), press this key to light up the EXT indication. (Change the Pr.79 value to use the combined mode.)
 PU: PU operation mode
 EXT: External operation mode

Used to set each setting.
 If pressed during operation, monitor changes as below;

Running frequency → Output current → Output voltage *

* Energy saving monitor is displayed when the energy saving monitor of Pr. 52 is set.

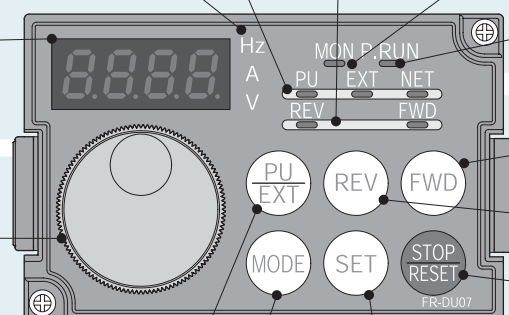
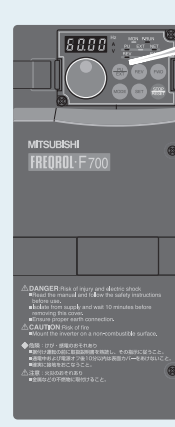
3.2.2 Basic operation (factory setting)

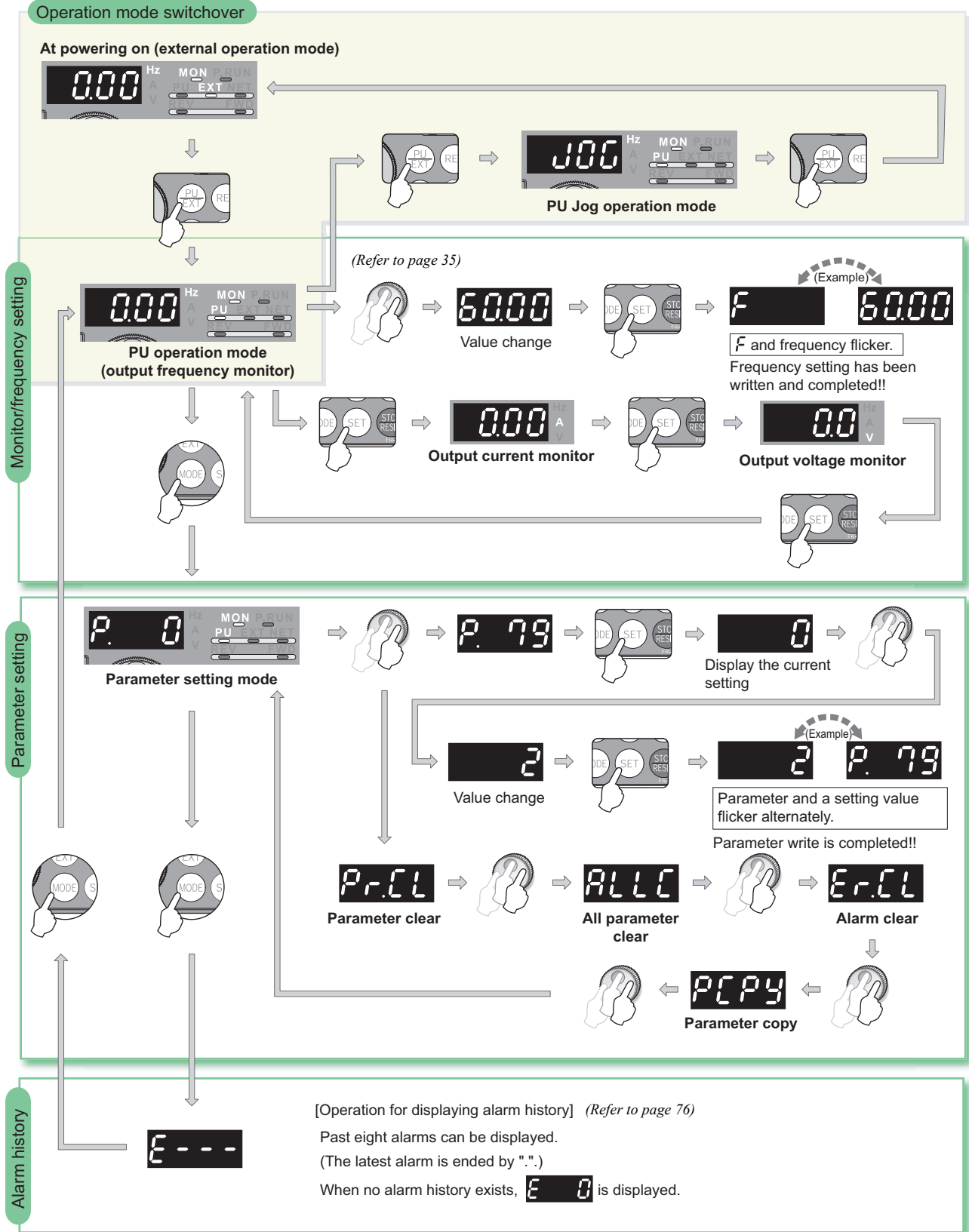

3.2.3 Operation lock (Press [MODE] for an extended time (2s))

Operation using the setting dial and key of the operation panel can be made invalid to prevent parameter change and unexpected start and stop.

- Set "10 or 11" in Pr. 161, then press for 2s to make the setting dial and key operation invalid.
- When the setting dial and key operation is made invalid, **HOLD** appears on the operation panel.

When the setting dial and key operation is invalid, **HOLD** appears if the setting dial or key operation is performed. (When the setting dial or key operation is not performed for 2s, the monitor display appears.)

- To make the setting dial and key operation valid again, press for 2s.

POINT

Set "0" (extended mode parameter valid) in Pr.160 User group read selection.

Set "10 or 11" (key lock mode valid) in Pr.161 Frequency setting/key lock operation selection.

Operation	Display
1. Screen at powering on The monitor display appears.	
2. Press to choose the PU operation mode.	PU indication is lit.
3. Press to choose the parameter setting mode.	 (The parameter number read previously appears.)
4. Turn until P. 161 (Pr. 161) appears.	
5. Press to read the currently set value. "0" (initial value) appears.	
6. Turn counterclockwise to change it to the setting value of "10".	
7. Press to set.	 Flicker ... Parameter setting complete!!
8. Press for 2s to show the key lock mode.	 Press for 2s.

Functions valid even in the operation lock status

Stop and reset with .

REMARKS

Pr. 161 will not be displayed when simple mode (Pr. 160 User group read selection="9999") is selected. (Refer to page 51)



3.2.4 Monitoring of output current and output voltage

POINT

Monitor display of output frequency, output current and output voltage can be changed by pushing (SET) during monitoring mode.

Operation		Display
1. Press (MODE) during operation to choose the output frequency monitor		
2. Independently of whether the inverter is running in any operation mode or at a stop, the output current monitor appears by pressing (SET).	(SET) →	
3. Press (SET) to show the output voltage monitor.	(SET) →	

3.2.5 First priority monitor

Hold down (SET) for 1s to set monitor description to be appeared first in the monitor mode.

(To return to the output frequency monitor, hold down (SET) for 1s after displaying the output frequency monitor.)

3.2.6 Setting dial push

Push the setting dial () to display the set frequency currently set.



3.3 Overheat protection of the motor by the inverter (Pr.9)

Set this parameter when using a motor other than the Mitsubishi standard motor (SF-JR) and Mitsubishi constant torque motor (SF-HRCA).

Set the rated motor current in Pr. 9 Electronic thermal O/L relay to protect the motor from overheat.

Parameter Number	Name	Initial Value	Setting Range	Description	
9	Electronic thermal O/L relay	Rated inverter output current *1	FR-F720-02330 (FR-F740-01160) or less	0 to 500A	Set the rated motor current.
			FR-F720-03160 (FR-F740-01800) or more	0 to 3600A	

*1 Refer to page 92 for the rated inverter current value.

The minimum setting increments are 0.01A for the FR-F720-02330 (FR-F740-01160) or less and 0.1A for the R-F720-03160 (FR-F740-01800) or more.

Changing example Change the Pr. 9 Electronic thermal O/L relay setting to 2.5A according to the motor rated current.

Operation

1. Screen at powering on
The monitor display appears.
2. Press **PU/EXT** to choose the PU operation mode.
3. Press **MODE** to choose the parameter setting mode.
4. Turn **▲** until Pr. 9 electronic thermal O/L relay appears.
5. Press **SET** to show the currently set value. (2.1A for FR-F740-00023)
6. Turn **▲** clockwise to change the set value to "2.5". (2.5A)
7. Press **SET** to set.

Display

PU indication is lit.

(The parameter number read previously appears.)

(Refer to page 92 for initial value of the inverter rated current.)

Flicker ... Parameter setting complete!!

- By turning **▲**, you can read another parameter.
- Press **SET** to show the setting again.
- Press **SET** twice to show the next parameter.

CAUTION

- Protective function by electronic thermal relay function is reset by inverter power reset and reset signal input. Avoid unnecessary reset and power-off.
- When two or more motors are connected to the inverter, they cannot be protected by the electronic thermal relay function. Install an external thermal relay to each motor.
- When the difference between the inverter and motor capacities is large and the setting is small, the protective characteristics of the electronic thermal relay function will be deteriorated. In this case, use an external thermal relay.
- A special motor cannot be protected by the electronic thermal relay function. Use an external thermal relay.
- PTC thermistor output built-in the motor can be input to the PTC signal (AU terminal). For details, refer to the *Instruction Manual (applied)*.



3.4 When the rated motor frequency is 50Hz (Pr.3)

First, check the motor rating plate. If a frequency given on the rating plate is "50Hz" only, always set *Pr. 3 Base frequency* to "50Hz". Leaving the base frequency unchanged from "60Hz" may make the voltage low and the torque insufficient. It may result in an inverter trip (E.OC□) due to overload.

Parameter Number	Name	Initial Value	Setting Range	Description
3	Base frequency	60Hz	0 to 400Hz	Set the frequency when the motor rated torque is generated.

Changing example Change *Pr. 3 Base frequency* to 50Hz according to the motor rated frequency.

Operation	Display
1. Screen at powering on The monitor display appears.	
2. Press to choose the PU operation mode.	PU indication is lit.
3. Press to choose the parameter setting mode.	(The parameter number read previously appears.)
4. Turn until <i>Pr. 3 Base frequency</i> appears.	
5. Press to show the currently set value. (60Hz)	
6. Turn counterclockwise to change the set value to "50.0". (50Hz)	
7. Press to set.	

Flicker ... Parameter setting complete!!

- By turning , you can read another parameter.
- Press to show the setting again.
- Press twice to show the next parameter.

REMARKS

When an alarm trip (E.OC□) occurs, release the start command, and decrease the Pr. 1 value 1% by 1% to reset. Refer to *page 75* for reset.

3.5 Operation by the start command from the operation panel (PU operation mode)

POINT

From where is the frequency command given?

- Operation at the frequency set in the frequency setting mode of the operation panel →refer to 3.5.1 (refer to page 35.)
- Operation using the setting dial as the volume →refer to 3.5.2 (refer to page 36)
- Change of frequency with ON/OFF switches connected to terminals →refer to 3.5.3 (refer to page 37)
- Frequency setting with a voltage output device →refer to 3.5.4 (refer to page 39)
- Frequency setting with a current output device →refer to 3.5.5 (refer to page 41)

[Connection diagram]

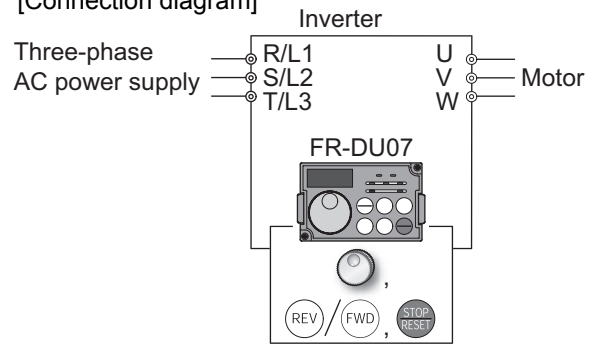

3.5.1 Set the set frequency to operate (example: performing operation at 30Hz)

Operation

1. Screen at powering on
The monitor display appears.
2. Press **PU/EXT** to choose the PU operation mode.
3. Turn **○** to show the frequency you want to set.
The frequency flickers for about 5s.
4. While the value is flickering, press **SET** to set the frequency.
(If you do not press **SET**, the value flickers for about 5s and the display then returns to 0.00 (display) Hz. At this time, return to "Step 3" and set the frequency again.)
5. After the value flickered for about 3s, the display returns to 0.00 (monitor display).
Press **FWD** (or **REV**) to start operation.
6. To change the set frequency, perform the operation in above steps 3 and 4.
(Starts from the previously set frequency.)
7. Press **STOP/RESET** to stop.

Display



PU indication is lit.



Flicker ... Frequency setting complete!!

↓ 3s later



- ? Operation cannot be performed at the set frequency ... Why?
☞ Did you carry out step 4 within 5s after step 3? (Did you press **SET** within 5s after turning **○** ?)
- ? The frequency does not change by turning **○** ... Why?
☞ Check to see if the operation mode selected is the external operation mode. (Press **PU/EXT** to change to the PU operation mode.)
- ? Operation does not change to the PU operation mode ... Why?
☞ Check that "0" (initial value) is set in Pr.79 Operation mode selection.
☞ Check that the start command is not on.
- ? Change acceleration time ☞ Pr.7 (Refer to page 55)
- ? Change deceleration time ☞ Pr.8 (Refer to page 55)

☞ For example, limit the motor speed to 60Hz maximum. ☞ Set "60Hz" in Pr. 1. (Refer to page 54)

REMARKS





















- Press **○** to show the set frequency.
- **○** can also be used like a potentiometer to perform operation. (Refer to page 36)

3.5.2 Use the setting dial like a potentiometer to perform operation.

POINT

Set "0" (extended mode parameter valid) in Pr. 160 User group read selection.
Set "1" (setting dial potentiometer mode) in Pr. 161 Frequency setting/key lock operation selection.

Operation example Change the frequency from 0Hz to 60Hz during operation

Operation	Display
1. Screen at powering on The monitor display appears.	
2. Press  to choose the PU operation mode.	PU indication is lit. 
3. Press  to choose the parameter setting mode.	 (The parameter number previously read appears.)
4. Turn  until P. 161 (Pr. 161) appears.	
5. Press  to read the currently set value. "0" (initial value) appears.	
6. Turn  clockwise to change it to the setting value of "1".	
7. Press  to set.	
Flicker ... Parameter setting complete!!	
8. Mode/monitor check Press  twice to choose monitor/frequency monitor.	
9. Press  (or ) to start the inverter.	
10. Turn  clockwise until "60.00" appears. The flickering frequency is the set frequency. You need not press  .	 The frequency flickers for about 5s.

REMARKS

- If flickering "60.00" turns to "0.0", the Pr. 161 Frequency setting/key lock operation selection setting may not be "1".
- Independently of whether the inverter is running or at a stop, the frequency can be set by merely turning .
- Pr. 161 will not be displayed when simple mode (Pr. 160 User group read selection="9999") is selected. (Refer to page 51)

3.5.3 Use switches to give a start command and a frequency command (multi-speed setting)

POINT

- Use (FWD)/(REV) to give a start command.
- Pr. 79 Operation mode selection must be set to "4" (external/PU combined operation mode 2)
- The initial values of the terminals RH, RM, RL are 60Hz, 30Hz, and 10Hz. (Refer to page 45 to change frequencies using Pr. 4, Pr. 5 and Pr. 6.)
- Operation at 15-speed can be performed by turning on two (or three) terminals simultaneously. (Refer to the Instruction Manual (applied).)

[Connection diagram]

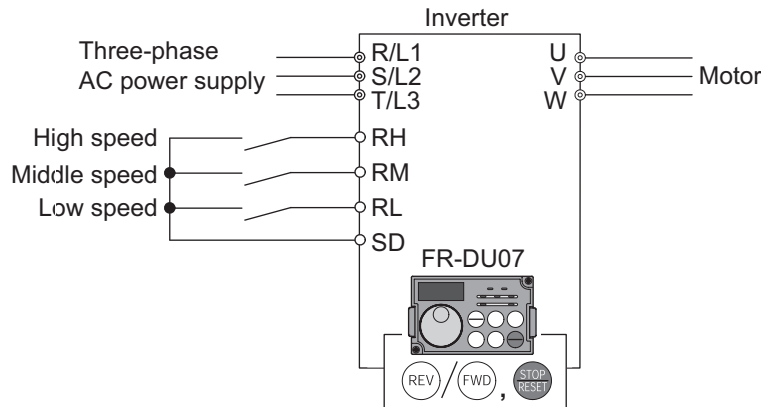

Operation

1. Screen at powering on
The monitor display appears.
2. Press (MODE) to choose the parameter setting mode.
3. Turn (rotary knob) until P. 79 (Pr. 79) appears.
4. Press (SET) to read the currently set value.
"0"(initial value) appears.
5. Turn (rotary knob) clockwise to change it to the setting value of "4".
6. Press (SET) to set.
7. Mode/monitor check
Press (MODE) twice to choose the monitor/frequency monitor.
8. Press the start switch (FWD) (or (REV)).
FWD (or REV) flickers.
When the frequency command is not given, it flickers.

Display

Flicker ... Parameter setting complete!!

Flickering

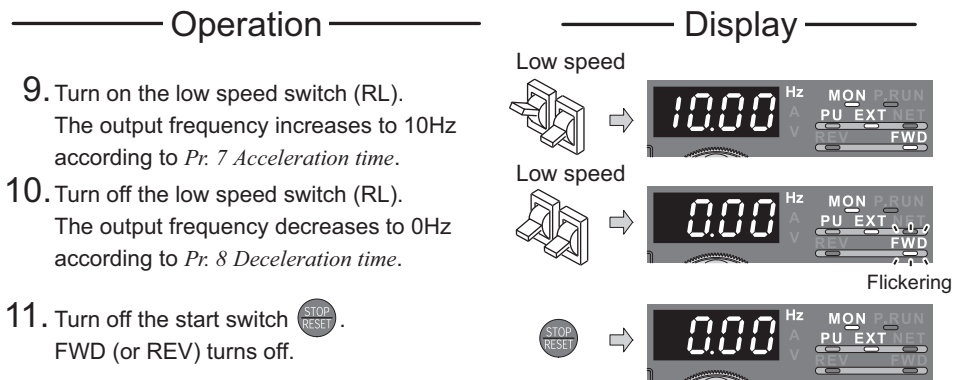

? 60Hz for the RH, 30Hz for the RL and 10Hz for the RL are not output when they are turned on ... Why?

- ☞ Check for the setting of *Pr. 4*, *Pr. 5*, and *Pr. 6* once again.
- ☞ Check for the setting of *Pr. 1 Maximum frequency* and *Pr.2 Minimum frequency* once again. (Refer to page 54.)
- ☞ Check that *Pr. 180 RL terminal function selection*="0", *Pr. 181 RM terminal function selection*="2", *Pr. 182 RH terminal function selection* and *Pr. 59 Remote function selection* ="0". (all are initial values)

? [FWD (or REV)] lamp is not lit ... Why?

- ☞ Check that wiring is correct. Check the wiring once again.
- ☞ Check for the *Pr. 79* setting once again. (*Pr. 79* must be set to "4".) (Refer to page 58.)

? Change the frequency of the terminal RL, RM, and RH. ... How?

- ☞ Refer to *page 45* to change the running frequency at each terminal in *Pr. 4 Multi-speed setting (high speed)*, *Pr. 5 Multi-speed setting (middle speed)*, and *Pr. 6 Multi-speed setting (low speed)*.

3.5.4 Perform frequency setting by analog (voltage input)

POINT

- Use (FWD)/(REV) to give a start command.
- Pr. 79 Operation mode selection must be set to "4" (external/PU combined operation mode 2)

[Connection diagram]

(The inverter supplies 5V of power to the frequency setting potentiometer.(Terminal 10))

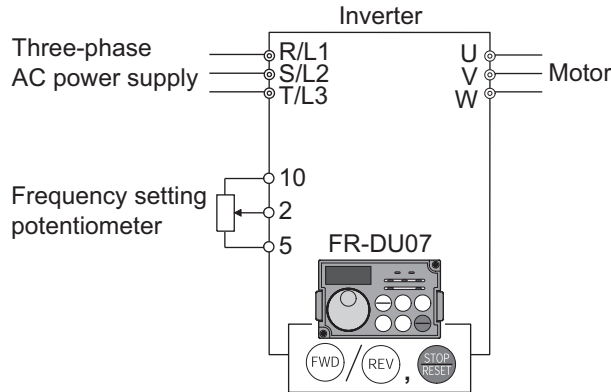

Operation

1. Screen at powering on
The monitor display appears.
2. Press (MODE) to choose the parameter setting mode.
3. Turn (potentiometer) until P. 79 (Pr. 79) appears.
4. Press (SET) to read the currently set value.
"0"(initial value) appears.
5. Turn (potentiometer) clockwise to change it to the setting value of "4".
6. Press (SET) to set.
7. Mode/monitor check
Press (MODE) twice to choose the monitor/frequency monitor.
8. Start
Press the start switch (FWD) (or (REV)).
Operation status indication of FWD (or REV) flickers.
- CAUTION**
When both the forward switch and reverse switch turn on, the inverter will not start.
Also, if both switch turn on while running, the inverter stops.
9. Acceleration → constant speed
Turn the volume (frequency setting potentiometer) clockwise slowly to full.
The frequency value on the indication increases according to Pr. 7 Acceleration time until 60Hz is displayed.

Display

Operation

10. Deceleration

Turn the volume (frequency setting potentiometer) counterclockwise slowly to full.

The frequency value on the indication decreases according to *Pr. 8 Deceleration time* until 0.00Hz is displayed and operation status indication of FWD or REV flickers.

The motor stops.

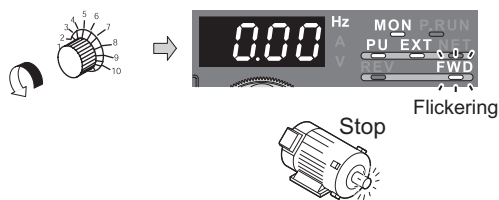

Display

11. Stop

Press .

Operation status indication of FWD (or REV) turns off.



? Change the frequency (60Hz) of the maximum value of potentiometer (at 5V)

 Adjust the frequency in *Pr. 125 Terminal 2 frequency setting gain frequency*. (Refer to page 48.)

? Change the frequency (0Hz) of the minimum value of potentiometer (at 0V)

 Adjust the frequency in *calibration parameter C2 Terminal 2 frequency setting bias frequency*. (Refer to the Instruction Manual (applied).)

3.5.5 Perform frequency setting by analog (current input)

POINT

- Use (FWD)/(REV) to give a start command.
- Turn the AU signal on.
- Pr. 79 Operation mode selection must be set to "4" (external/PU combined operation mode 2)

[Connection diagram]

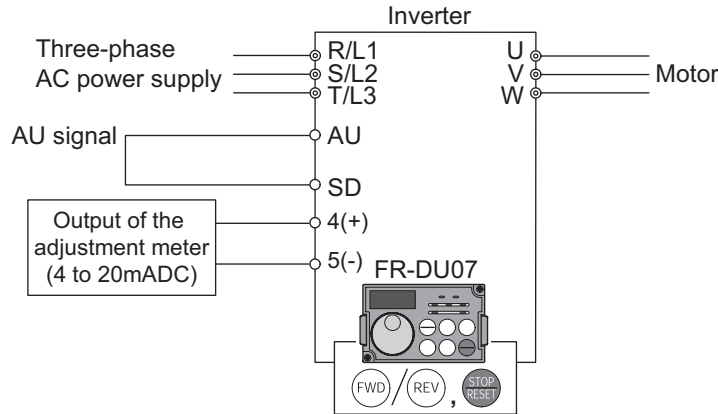

Operation

1. Screen at powering on
The monitor display appears.
2. Press (MODE) to choose the parameter setting mode.
3. Turn (rotary knob) until P. 79 (Pr. 79) appears.
4. Press (SET) to read the currently set value.
"0"(initial value) appears.
5. Turn (rotary knob) clockwise to change it to the setting value of "4".
6. Press (SET) to set.
7. Mode/monitor check
Press (MODE) twice to choose the monitor/frequency monitor.
8. Start
Check that the terminal 4 input selection signal (AU) is on.
Press the start switch (FWD) (or (REV)).
FWD or REV of operation status indication flickers.

Display



Flicker ... Parameter setting complete!!



CAUTION

When both the forward switch and reverse switch turn on, the inverter will not start. Also, if both switch turn on while running, the inverter stops.

Operation

9. Acceleration → constant speed
Perform 20mA input.
The frequency value on the indication increases according to Pr. 7 Acceleration time until 60.00Hz is displayed.
10. Deceleration
Perform 4mA input.
The frequency value on the indication decreases according to Pr. 8 Deceleration time until 0.00Hz is displayed and the operation status indication of FWD or REV flickers.
The motor stops.
11. Stop
Press .
FWD or REV of the operation status indication turns off.

Display

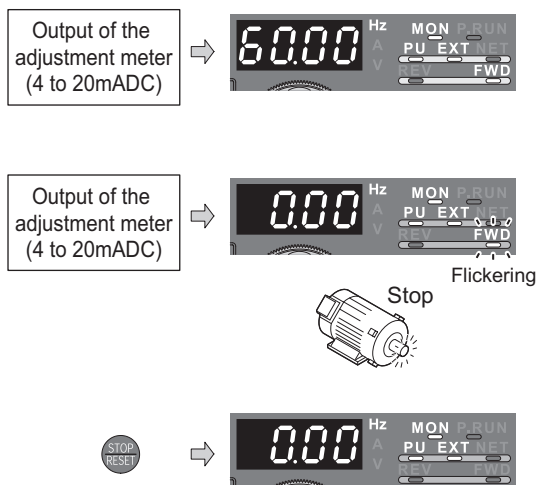

REMARKS

Pr. 184 AU terminal function selection must be set to "4" (AU signal) (initial value). (Refer to the Instruction Manual (applied).)

- ? Change the frequency (60Hz) at the maximum value of potentiometer (at 20mA)
 - ☞ Adjust the frequency in Pr. 126 Terminal 4 frequency setting gain frequency. (Refer to page 50.)
- ? Change the frequency (0Hz) at the minimum value of potentiometer (at 4mA)
 - ☞ Adjust the frequency in calibration parameter C5 Terminal 4 frequency setting bias frequency. (Refer to the Instruction Manual (applied).)

3.6 Operation by the start command of the terminal block (external operation)

POINT

From where is the frequency command given?

- Operation at the frequency set in the frequency setting mode of the operation panel → Refer to 3.6.1 (Refer to page 43)
- Give a frequency command by switch (multi-speed setting) → Refer to 3.6.2 (Refer to page 45)
- Perform frequency setting by a voltage output device → Refer to 3.6.3 (Refer to page 47)
- Perform frequency setting by a current output device → Refer to 3.6.5 (Refer to page 49)

3.6.1 Use the set frequency set by the operation panel (Pr. 79=3)

POINT

- Switch terminal STF(STR)-SD on to give a start command.
- Set "3" in Pr. 79 (External/PU combined operation mode 1).
- Refer to page 35 for the set frequency by the operation panel.

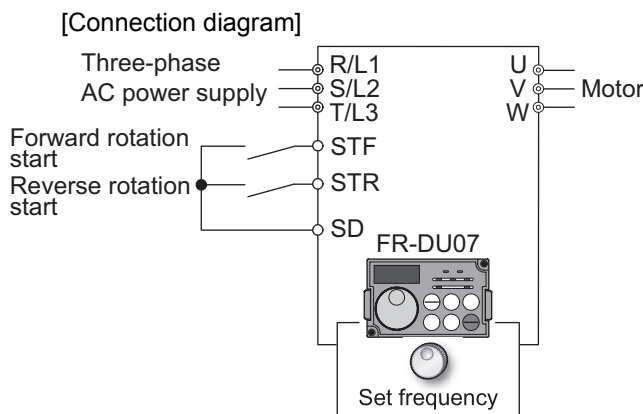

Operation	Display
1. Screen at powering on The monitor display appears.	
2. Press (MODE) to choose the parameter setting mode.	
3. Turn (Rocker) until P. 79 (Pr. 79) appears.	
4. Press (SET) to read the currently set value. "0"(initial value) appears.	
5. Turn (Rocker) clockwise to change it to the setting value of "3".	
6. Press (SET) to set.	
Flicker ... Parameter setting complete!!	
7. Turn the start switch (STF or STR) on. •The motor runs at the frequency set in the set frequency mode of the operation panel.	
8. Turn (Rocker) to change running frequency. Display the frequency you want to set. The frequency flickers for about 5s.	

Operation

Display

9. While the value is flickering, press **SET** to set the frequency.

(If you do not press **SET**, the value flickers for about 5s and the display then returns to 0.00 (display) Hz. At this time, return to "Step 3" and set the frequency again.)

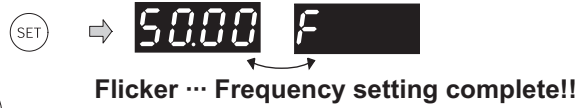

10. Turn the start switch (STF or STR) off. The motor decelerates according to Pr. 8 Deceleration time to stop.

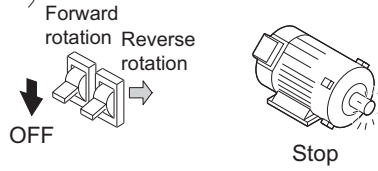

REMARKS

- Pr. 178 STF terminal function selection must be set to "60" (or Pr. 179 STR terminal function selection must be set to "61"). (all are initial values)
- When Pr. 79 Operation mode selection is set to "3", multi-speed operation (refer to page 45) is also made valid.

? When the inverter is stopped by **STOP/RESET** of the operation panel (FR-DU07), **PS** and **0.00** Hz



are displayed alternately.

1. Turn the start switch (STF or STR) off.
2. The display can be reset by **PU/EXT**.

3.6.2 Use switches to give a start command and a frequency command (multi-speed setting) (Pr. 4 to Pr.6)

POINT

- Start command by terminal STF (STR)-SD
- Frequency command by terminal RH, RM, RL and STR-SD
- [EXT] must be lit. (When [PU] is lit, switch it to [EXT] with PU/EXT .)
- The initial values of the terminals RH, RM, RL are 60Hz, 30Hz, and 10Hz. (Use Pr. 4, Pr. 5 and Pr. 6 to change.)
- Operation at 15-speed can be performed by turning two (or three) terminals simultaneously. (Refer to the Instruction Manual (applied).)

[Connection diagram]

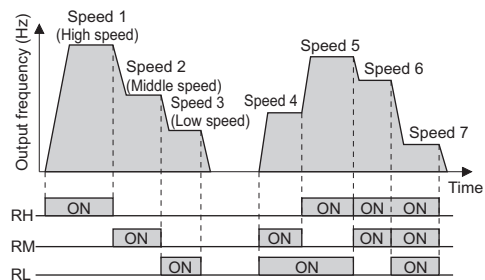
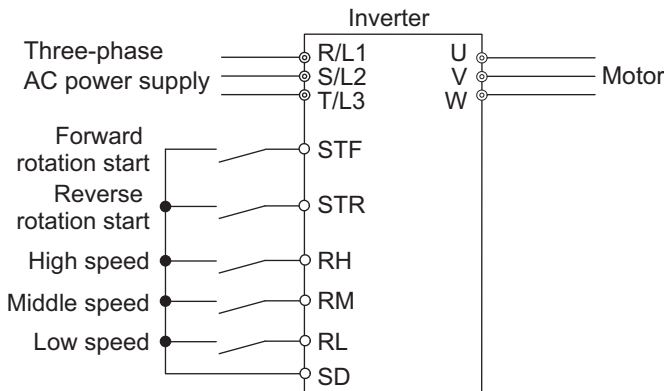

Changing example

Set "50Hz" in Pr. 4 Multi-speed setting (high speed) and turn on terminal RH and STF (STR)-SD to operate.

Operation	Display
<p>1. Power on → operation mode check For the initial setting, the inverter operates in the external operation mode [EXT] when powering on. Check that the operation command indication is [EXT]. If not displayed, press PU/EXT to change to the external [EXT] operation mode. If the operation mode still does not change, set Pr: 79 to change to the external operation mode. (Refer to page 58.)</p>	
<p>2. Press MODE to choose the parameter setting mode.</p>	<p>(The parameter number read previously appears.)</p>
<p>3. Turn ▲ until P. 4 (Pr. 4) appears.</p>	
<p>4. Press SET to read the currently set value. "6000"(initial value) appears. (60.00Hz)</p>	
<p>5. Turn ▲ counterclockwise to change it to the setting value of "5000". (50.00Hz)</p>	
<p>6. Press SET to set.</p>	
<p>Flicker ... Parameter setting complete!!</p>	



Operation

Display

7. Mode/monitor check
Press twice to choose the monitor/frequency monitor.



8. Turn on the high speed switch (RH).

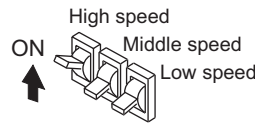

9. Turn the start switch (STF or STR) on.
50Hz appears.
• 30Hz appears when RM is on and 10Hz appears when RL is on.

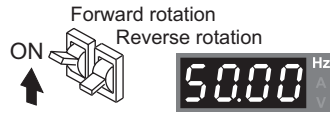

10. Stop
Turn the start switch (STF or STR) off.
The motor stops according to Pr. 8
Deceleration time.

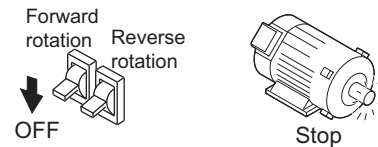

? [EXT] is not lit even when is pressed ... Why?

Switchover of the operation mode with is valid when Pr. 79 = "0" (initial value).

? 60Hz, 30Hz and 10Hz are not output from RH, RM and RL respectively when they are turned on. ... Why?

- Check for the setting of Pr. 4, Pr. 5, and Pr. 6 once again.
- Check for the setting of Pr. 1 Maximum frequency and Pr. 2 Minimum frequency once again. (Refer to page 54)
- Check for the Pr. 79 setting once again. (Pr. 79 must be set to "0" or "2".) (Refer to page 58)
- Check that Pr. 180 RL terminal function selection="0", Pr. 181 RM terminal function selection="1", Pr. 182 RH terminal function selection ="2" and Pr. 59 Remote function selection ="0". (all are initial values)

? [FWD (or REV)] is not lit. ... Why?

- Check that wiring is correct. Check it again.
- Check that "60" is set in Pr. 178 STF terminal function selection (or "61" is set in Pr. 179 STR terminal function selection)? (all are initial values)

? How is the frequency setting from 4 to 7 speed ?

The setting differs according to Pr. 24 to Pr. 27 (multi-speed setting). Refer to the Instruction Manual (applied).

? Perform multi-speed operation higher than 8 speed. ... How?

Use the REX signal to perform the operation. Refer to the Instruction Manual (applied).

REMARKS

- External operation is fixed by setting "2" (external operation mode) in Pr. 79 Operation mode selection when you do not want to take time pressing or when you want to use the current operation command and frequency command. (Refer to page 58)

3.6.3 Perform frequency setting by analog (voltage input)

[Connection diagram]

(The inverter supplies 5V of power to frequency setting potentiometer. (Terminal 10))

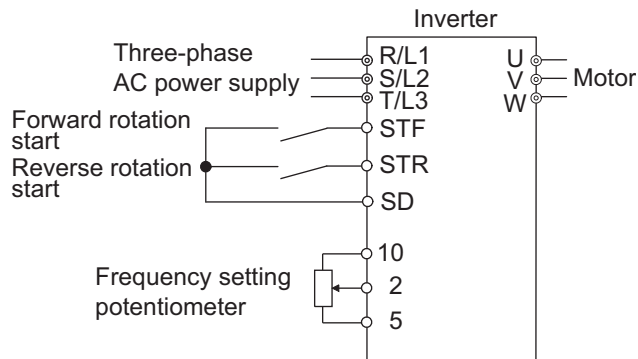

Operation	Display
<p>1. Power on → operation mode check For the initial setting, the inverter operates in the external operation mode [EXT] when powering on. Check that the operation command indication is [EXT]. If not displayed, press to change to the external [EXT] operation mode. If the operation mode still does not change, set Pr. 79 to change to the external operation mode. (Refer to page 58.)</p>	<p style="text-align: center;">ON</p>
<p>2. Start Turn the start switch (STF or STR) on. Operation status indication of FWD (or REV) flickers.</p> <p style="text-align: center;">CAUTION</p> <p>When both the forward switch and reverse switch are on, the inverter will not start. Also, if both switches turn on while running, the inverter decelerates to stop.</p>	<p style="text-align: center;">Forward rotation Reverse rotation</p> <p style="text-align: center;">ON</p> <p style="text-align: right;">Flickering</p>
<p>3. Acceleration → constant speed Turn the volume (frequency setting potentiometer) clockwise slowly to full. The frequency value on the indication increases according to Pr. 7 Acceleration time until 60Hz is displayed.</p>	
<p>4. Deceleration Turn the volume (frequency setting potentiometer) counterclockwise slowly to full. The frequency value of the indication decreases according to Pr. 8 Deceleration time until 0.00Hz is displayed. The motor stops.</p>	<p style="text-align: right;">Flickering</p> <p style="text-align: center;">Stop</p>
<p>5. Stop Turn the start switch (STF or STR) off.</p>	<p style="text-align: center;">Forward rotation Reverse rotation</p> <p style="text-align: center;">OFF</p>



When you want to operate in the external operation mode always at powering on or when you want to save the trouble of input, set "2" (external operation mode) in Pr. 79 Operation mode selection to choose external operation mode always.

REMARKS

Pr. 178 STF terminal function selection must be set to "60" (or Pr. 179 STR terminal function selection must be set to "61"). (all are initial values)

? The motor will not rotate ... Why?

☞ Check that [EXT] is lit.
[EXT] is valid when Pr. 79 = "0" (initial value).

Use $\frac{PU}{EXT}$ to lit [EXT].

☞ Check that wiring is correct. Check once again.

? Change the frequency (0Hz) of the minimum value of potentiometer (at 0V)

☞ Adjust the frequency in calibration parameter C2 Terminal 2 frequency setting bias frequency. (Refer to the Instruction Manual (applied).)











☞ When you want to compensate frequency setting, use terminal 1.
For details, refer to the Instruction Manual (applied).

3.6.4 Change the frequency (60Hz) of the maximum value of potentiometer (at 5V)

<How to change the maximum frequency?>

Changing example

When you want to use the 0 to 5VDC input frequency setting potentiometer to change the 5V-time frequency from 60Hz (initial value) to 50Hz
Adjust to output 50Hz at 5V voltage input.
Set "50Hz" in Pr. 125.

Operation	Display
1. Turn  until P. 125 (Pr. 125) appears.	
2. Press  to show the currently set value. (60.00Hz)	
3. Turn  to change the set value to "50.00". (50.00Hz)	
4. Press  to set.	
5. Mode/monitor check Press  twice to choose the monitor/frequency monitor.	
6. Turn the start switch (STF or STR) on and turn the volume (frequency setting potentiometer) clockwise to full slowly. (Refer to 3.6.3 steps 2 to 5)	Flicker ... 50Hz output at 5V input complete!!

? E-3 (error at writing) is displayed.

☞ The gain and bias frequency settings are too close.

? Set frequency at 0V using calibration parameter C2 and adjust the indicator using calibration parameter C0.
(Refer to the Instruction Manual (applied).)

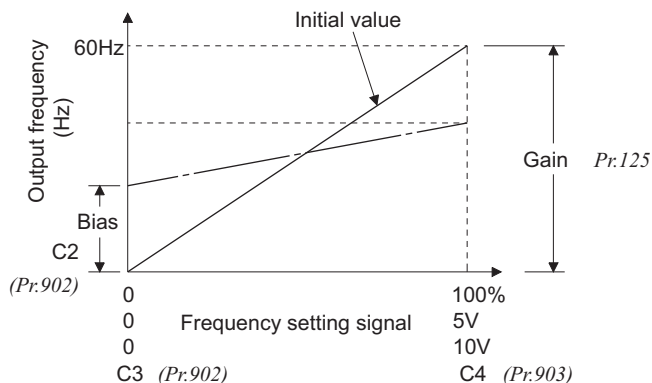

REMARKS

As other adjustment methods of frequency setting voltage gain, there are methods to adjust with a voltage applied to across terminals 2-5 and adjust at any point without a voltage applied.
(Refer to the Instruction Manual (applied) for the setting method of calibration parameter C4.)

3.6.5 Perform frequency setting by analog (current input)

POINT

- Switch terminal STF(STR)-SD on to give a start command.
- Turn the AU signal on.
- Set "2" (external operation mode) in Pr. 79 Operation mode selection

[Connection diagram]

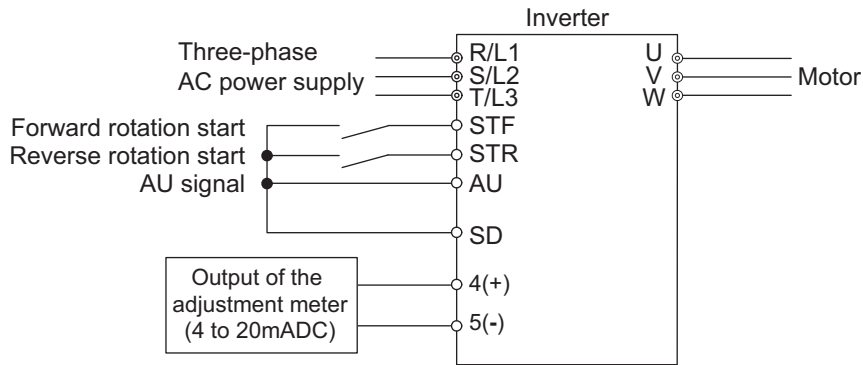

Operation

1. Power on → operation mode check
For the initial setting, the inverter operates in the external operation mode [EXT] when powering on. Check that the operation command indication is [EXT]. If not displayed, press $\left(\begin{smallmatrix} PU \\ EXT \end{smallmatrix}\right)$ to change to the external [EXT] operation mode. If the operation mode still does not change, set Pr. 79 to change to the external operation mode. (Refer to page 58.)



2. Start
Turn the start switch (STF or STR) on.
FWD or REV of operation indication flickers.

CAUTION

When both the forward switch and reverse switch are on, the inverter will not start. Also, if both switches turn on while running, the inverter decelerates to stop.

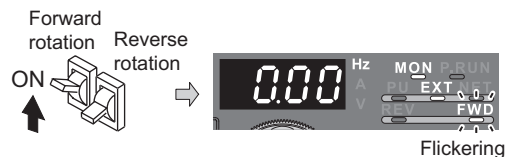

3. Acceleration → constant speed
Perform 20mA input.
The frequency value on the indication increases according to Pr. 7
Acceleration time until 60Hz is displayed.



4. Deceleration
Perform 4mA input.
The frequency value on the indication decreases according to Pr. 8
Deceleration time until 0.00Hz is displayed and FWD or REV of the operation status indication flickers.
The motor stops.

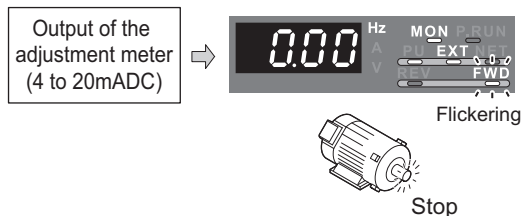

5. Stop
Turn the start switch (STF or STR) off.



REMARKS

Pr. 184 AU terminal function selection must be set to "4" (AU signal) (initial value). (Refer to the Instruction Manual (applied).)

? The motor will not rotate ... Why?

☞ Check that [EXT] is lit.
[EXT] is valid when Pr. 79 = "0" (initial value).

Use $\left(\frac{PU}{EXT}\right)$ to lit [EXT].

☞ Check that the AU signal is on.
Turn the AU signal on.

☞ Check that wiring is correct. Check it again.

? Change the frequency (0Hz) of the minimum value of potentiometer (at 4mA)

☞ Adjust the frequency in calibration parameter C5 Terminal 4 frequency setting bias frequency.
(Refer to the Instruction Manual (applied).)

3.6.6 Change the frequency (60Hz) of the maximum value of potentiometer (at 20mA)

<How to change the maximum frequency?>

Changing example

When you want to use the 4 to 20mA input frequency setting potentiometer to change the 20mA-time frequency from 60Hz (initial value) to 50Hz
Adjust to output 50Hz at 20mA current input.
Set "50Hz" in Pr. 126.

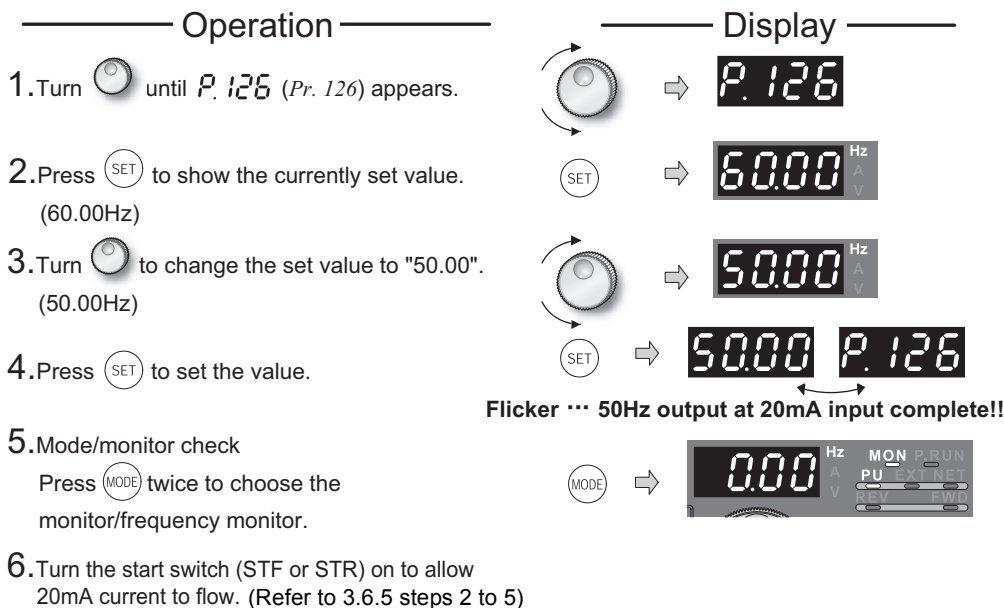

? E-3 (error at writing) is displayed.

☞ The gain and bias frequency settings are too close.

? Set frequency at 4mA using calibration parameter C5 and adjust the indicator using calibration parameter C0.
(Refer to the Instruction Manual (applied).)

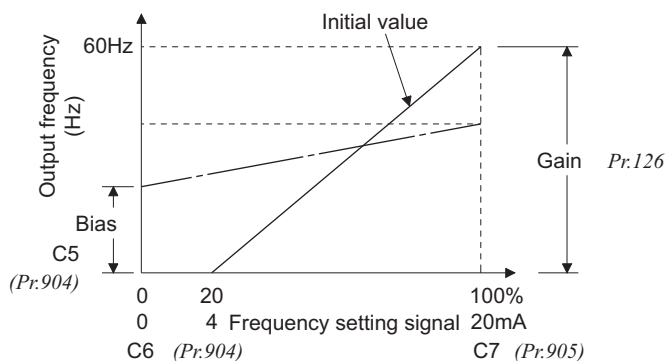

REMARKS

As other adjustment methods of frequency setting voltage gain, there are methods to adjust with a voltage applied to across terminals 4-5 and adjust at any point without a voltage applied.
(Refer to the Instruction Manual (applied) for the setting method of calibration parameter C7.)

4 ADJUSTMENT

4.1 Simple mode parameter list

For simple variable-speed operation of the inverter, the initial setting of the parameters may be used as they are. Set the necessary parameters to meet the load and operational specifications. Parameter setting, change and check can be made from the operation panel (FR-DU07). For details of parameters, refer to the *Instruction Manual (applied)*.

Pr. 160	Description
9999	Only the simple mode parameters can be displayed.
0 (Initial Value)	Simple mode and extended mode parameters can be displayed.
1	Only the parameters registered in the user group can be displayed.

Display the simple mode parameters only.

Operation	Display
1. Screen at powering on The monitor display appears.	
2. Press to choose the PU operation mode.	PU indication is lit.
3. Press to choose the parameter setting mode.	 (The parameter number read previously appears.)
4. Turn until P. 160 (Pr. 160) appears.	
5. Press to read the currently set value. "0" (initial value) appears.	
6. Turn to change it to the set value of "9999".	
7. Press to set.	

Flicker ... Parameter setting complete!!

- By turning , you can read another parameter.
- Press to show the setting again.
- Press twice to show the next parameter.

After parameter setting is completed, press once to show the alarm history and press twice to return to the monitor display. To change settings of other parameters, perform the operation in above steps 3 to 7.

? Error display?

Err 1 If the operation panel does not have the write precedence

REMARKS

If the setting has not been changed, the value does not flicker and the next parameter number appears.



Parameter Number	Name	Increments	Initial Value	Range	Applications	Refer to																								
0	Torque boost	0.1%	6/4/3/2/ 1.5/1% *1	0 to 30%	<p>Set to increase a starting torque or when the motor with a load will not rotate, resulting in an alarm [OL] and a trip [OC1]</p> <p>*1 Initial values differ according to the inverter capacity.</p> <table border="1"> <thead> <tr> <th colspan="2">Inverter capacity</th> <th>Initial value</th> </tr> <tr> <th>200V class</th> <th>400V class</th> <th></th> </tr> </thead> <tbody> <tr> <td>00046</td> <td>00023</td> <td>6%</td> </tr> <tr> <td>00077 to 00167</td> <td>00038 to 00083</td> <td>4%</td> </tr> <tr> <td>00250, 00340</td> <td>00126, 00170</td> <td>3%</td> </tr> <tr> <td>00490 to 01540</td> <td>00250 to 00770</td> <td>2%</td> </tr> <tr> <td>01870, 02330</td> <td>00930, 01160</td> <td>1.5%</td> </tr> <tr> <td>03160 or more</td> <td>01800 or more</td> <td>1%</td> </tr> </tbody> </table>	Inverter capacity		Initial value	200V class	400V class		00046	00023	6%	00077 to 00167	00038 to 00083	4%	00250, 00340	00126, 00170	3%	00490 to 01540	00250 to 00770	2%	01870, 02330	00930, 01160	1.5%	03160 or more	01800 or more	1%	53
Inverter capacity		Initial value																												
200V class	400V class																													
00046	00023	6%																												
00077 to 00167	00038 to 00083	4%																												
00250, 00340	00126, 00170	3%																												
00490 to 01540	00250 to 00770	2%																												
01870, 02330	00930, 01160	1.5%																												
03160 or more	01800 or more	1%																												
1	Maximum frequency	0.01Hz	120/ 60Hz*2	0 to 120Hz	Set when the maximum and minimum output frequency need to be limited.	54																								
2	Minimum frequency	0.01Hz	0Hz	0 to 120Hz	*2 Initial values differ according to the inverter capacity. (FR-F720-02330 (FR-F740-01160) or less/ FR-F720-03160 (FR-F740-01800) or more)																									
3	Base frequency	0.01Hz	60Hz	0 to 400Hz	Set when the rated motor frequency is 50Hz. Check the motor rating plate.	34																								
4	Multi-speed setting (high speed)	0.01Hz	60Hz	0 to 400Hz	Set when changing the preset speed in the parameter with a terminal.	45																								
5	Multi-speed setting (middle speed)	0.01Hz	30Hz	0 to 400Hz																										
6	Multi-speed setting (low speed)	0.01Hz	10Hz	0 to 400Hz																										
7	Acceleration time	0.1s	5/15s*3	0 to 3600s	Acceleration/deceleration time can be set.	55																								
8	Deceleration time	0.1s	10/30s*3	0 to 3600s	*3 Initial values differ according to the inverter capacity. (FR-F720-00340 (FR-F740-00170) or less/FR-F720-00490 (FR-F740-00250) or more)																									
9	Electronic thermal O/L relay	0.01/ 0.1A*4	Rated inverter output current	0 to 500/ 0 to 3600A*4	Protect the motor from overheat by the inverter. Set the rated motor current.	33																								
					*4 Setting increments and setting range differ according to the inverter capacity. (FR-F720-02330 (FR-F740-01160) or less/ FR-F720-03160 (FR-F740-01800) or more)																									
60	Energy saving control selection	1	0	0, 4, 9	The inverter output voltage is minimized when using for fan and pump applications.	56																								
79	Operation mode selection	1	0	0, 1, 2, 3, 4, 6, 7	Select the operation command location and frequency command location.	58																								
125	Terminal 2 frequency setting gain frequency	0.01Hz	60Hz	0 to 400Hz	Frequency for the maximum value of the potentiometer (at 5V) can be changed.	48																								
126	Terminal 4 frequency setting gain frequency	0.01Hz	60Hz	0 to 400Hz	Frequency at 20mA input can be changed.	50																								
160	User group read selection	1	0	0, 1, 9999	Make extended parameters invalid	107																								



4.2 Increase the starting torque (Pr. 0)

Set this parameter when "the motor with a load will not rotate", "an alarm [OL] is output, resulting in an inverter trip due to [OC1], etc.

Parameter Number	Name	Initial Value 200V class (400V class)	Setting Range	Description	
0	Torque boost	00046 (00023)	6%	0 to 30%	Motor torque in the low-frequency range can be adjusted to the load to increase the starting motor torque.
		00077 to 00167 (00038 to 00083)	4%		
		00250, 00340 (00126, 00170)	3%		
		00490 to 01540 (00250 to 00770)	2%		
		01870, 02330 (00930, 01160)	1.5%		
		03160 (01800) or more	1%		

Changing example When the motor with a load will not rotate, increase the Pr. 0 value 1% by 1% unit by looking at the motor movement. (The guideline is for about 10% change at the greatest.)

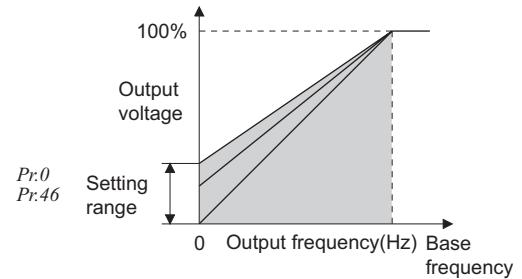

Operation

- Screen at powering on
The monitor display appears.
- Press to choose the PU operation mode.
- Press to choose the parameter setting mode.
- Turn until **P. 0** (Pr. 0) appears.
- Press to read the currently set value.
"6.0" (initial value is 6% for the FR-F740-00023) appears.
- Turn to change it to the set value of "7.0".
- Press to set.

Display



PU indication is lit.

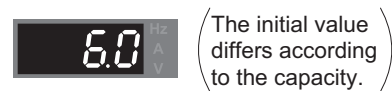
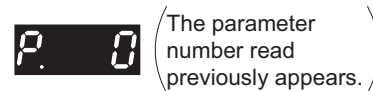

Flicker ... Parameter setting complete!!

- By turning , you can read another parameter.
- Press to show the setting again.
- Press twice to show the next parameter.

REMARKS

- A too large setting will cause the motor to overheat, resulting in an overcurrent trip (OL (overcurrent alarm) then E.OC1 (overcurrent shutoff during acceleration)), thermal trip (E.THM (Motor overload shutoff), and E.THT (Inverter overload shutoff)). When an error (E.OC1) occurs, release the start command, and decrease the Pr. 0 value 1% by 1% to reset. (Refer to page 68.)

POINT

If the inverter still does not operate properly after the above measures, adjust Pr. 80 "Simple magnetic vector control" [extended mode]. (Refer to the Instruction Manual (applied).)



4.3 Limit the maximum and minimum output frequency (Pr.1, Pr.2)

Parameter Number	Name	Initial Value		Setting Range	Description
		200V class (400V class)			
1	Maximum frequency	02330 (01160) or less	120Hz	0 to 120Hz	Set the upper limit of the output frequency.
		03610 (01800) or more	60Hz		
2	Minimum frequency	0Hz		0 to 120Hz	Set the lower limit of the output frequency.

Changing example You can limit the motor speed. Limit the frequency set by the potentiometer, etc. to 60Hz maximum.
(Set "60"Hz to Pr.1 Maximum frequency.)

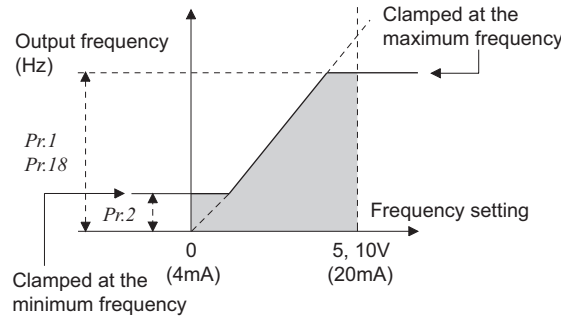

Operation

1. Screen at powering on
The monitor display appears.
2. Press **PU/EXT** to choose the PU operation mode.
3. Press **MODE** to choose the parameter setting mode.
4. Turn **⌚** until **P. 1** (Pr. 1) appears.
5. Press **SET** to read the currently set value.
"1200"(initial value) appears.
6. Turn **⌚** to change it to the set value of "6000".
7. Press **SET** to set.

Display

Flicker ... Parameter setting complete!!

- By turning **⌚**, you can read another parameter.
- Press **SET** to show the setting again.
- Press **SET** twice to show the next parameter.

REMARKS

- The output frequency is clamped by the Pr. 2 setting even the set frequency is lower than the Pr. 2 setting (The frequency will not decrease to the Pr. 2 setting.)
Note that Pr.15 Jog frequency has higher priority than the minimum frequency.
- When the Pr.1 setting is changed, frequency higher than the Pr.1 setting can not be set by **⌚**.
- When performing a high speed operation at 120Hz or more, setting of Pr.18 High speed maximum frequency is necessary. (Refer to the Instruction Manual (applied).)

CAUTION

⚠ If the Pr.2 setting is higher than the Pr.13 Starting frequency value, note that the motor will run at the set frequency according to the acceleration time setting by merely switching the start signal on, without entry of the command frequency.

4.4 Change acceleration and deceleration time (Pr.7, Pr.8)

Set in *Pr.7 Acceleration time* a larger value for a slower speed increase and a smaller value for a faster speed increase.
Set in *Pr.8 Deceleration time* a larger value for a slower speed decrease and a smaller value for a faster speed decrease.

Parameter Number	Name	Initial Value 200V class (400V class)		Setting Range	Description
7	Acceleration time	00340 (00170) or less	5s	0 to 3600/ 360s *	Set the motor acceleration time.
		00490 (00250) or more	15s		
8	Deceleration time	00340 (00170) or less	10s	0 to 3600/ 360s *	Set the motor deceleration time.
		00490 (00250) or more	30s		

* Depends on the *Pr.21 Acceleration/deceleration time increments* setting. The initial value for the setting range is "0 to 3600s" and setting increments is "0.1s".

Changing example Change the *Pr. 7 Acceleration time* setting from "5s" to "10s".

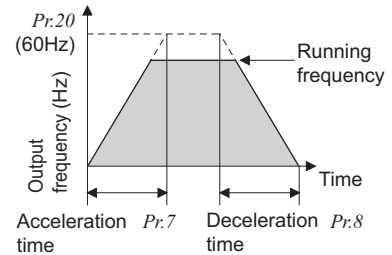

Operation

- Screen at powering on
The monitor display appears.
- Press **PU/EXT** to choose the PU operation mode.
- Press **MODE** to choose the parameter setting mode.
- Turn **▲** until **P. 7** (*Pr. 7*) appears.
- Press **SET** to read the currently set value.
"5.0"(initial value) appears.
- Turn **▲** to change it to the set value of "10.0".
- Press **SET** to set.

Display

Flicker ... Parameter setting complete!!

- By turning **▲**, you can read another parameter.
- Press **SET** to show the setting again.
- Press **SET** twice to show the next parameter.



4.5 Energy saving operation (Pr. 60)

Without a fine parameter setting, the inverter automatically performs energy saving operation.
This inverter is appropriate for fan and pump applications

Parameter Number	Name	Initial Value	Setting Range	Remarks
60	Energy saving control selection	0	0	Normal operation mode
			4	Energy saving operation mode
			9	Optimum excitation control mode

4.5.1 Energy saving operation mode (setting "4")

- When "4" is set in Pr. 60, the inverter operates in the energy saving operation mode.
- In the energy saving operation mode, the inverter automatically controls the output voltage to minimize the inverter output voltage during a constant operation.

REMARKS

- When the energy saving mode is selected, the *Pr. 0 Torque boost* and *Pr. 14 Load pattern selection* settings are made invalid to automatically control the output voltage.
- For applications a large load torque is applied to or machines repeat frequent acceleration/deceleration, an energy saving effect is not expected.

4.5.2 Optimum excitation control mode (setting "9")

- When "9" is set in *Pr. 60*, the inverter operates in the optimum excitation control mode.
- The optimum excitation control mode is a control system which controls excitation current to improve the motor efficiency to maximum and determines output voltage as an energy saving method.

REMARKS

- When the motor capacity is too small as compared to the inverter capacity or two or more motors are connected to one inverter, the energy saving effect is not expected.

CAUTION

- When the energy saving mode and optimum excitation control mode are selected, deceleration time may be longer than the setting value. Since overvoltage alarm tends to occur as compared to the constant torque load characteristics, set a longer deceleration time.
- The energy saving mode and optimum excitation control functions only under V/F control.
When a value other than "9999" is set in *Pr. 80 Motor capacity (simple magnetic flux control)*, the energy saving mode and optimum excitation control does not function.
(For simple magnetic flux vector control, refer to *the Instruction Manual (applied)*.)

POINT

When you want to check the energy saving effect, refer to *the Instruction Manual (applied)* to check the energy saving effect monitor.



Operation

Display

1. Screen at powering on
The monitor display appears.
2. Press to choose the PU operation mode.
3. Press to choose the parameter setting mode.
4. Turn until *P. 60* (Pr. 60) appears.
5. Press to read the currently set value.
"0" (initial value) appears.
6. Turn to change it to the set value of "4".
7. Press to set.
8. Perform normal operation.
When you want to check the energy saving effect, refer to the instruction manual applied to check the energy saving effect monitor.

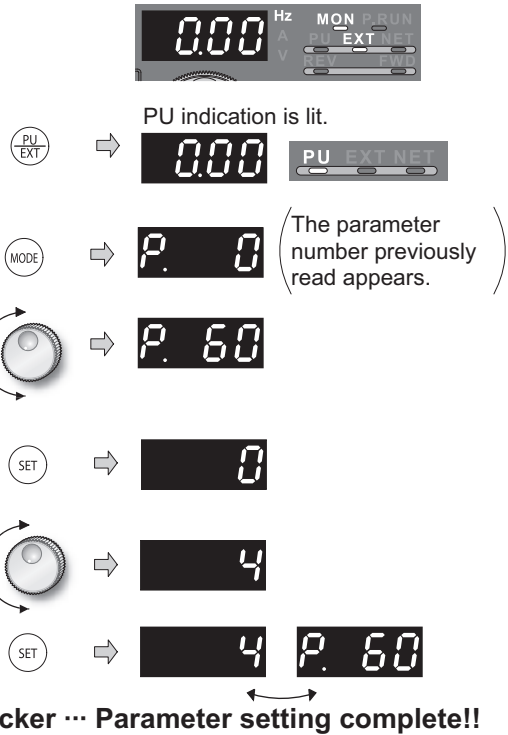

- By turning , you can read another parameter.
- Press to show the setting again.
- Press twice to show the next parameter.























REMARKS

If the motor decelerates to stop, the deceleration time may be longer than the set time. Since overvoltage tends to occur as compared to the constant torque characteristics, set a longer deceleration time.



4.6 Selection of the operation command and frequency command locations (Pr.79)

Select the operation command location and frequency command location.

Parameter Number	Name	Initial Value	Setting Range	Description	LED Indication  : Off  : On						
79	Operation mode selection	0	0	Use external/PU switchover mode (press  to switch between the PU and external operation mode. (Refer to page 35)) At power on, the inverter is in the external operation mode.	External operation mode  EXT PU operation mode  EXT						
			1	Fixed to PU operation mode	 PU						
			2	Fixed to external operation mode Operation can be performed by switching between the external and NET operation mode.	External operation mode  EXT NET operation mode  NET						
			3	External/PU combined operation mode 1		<table border="1"> <thead> <tr> <th>Running frequency</th> <th>Start signal</th> </tr> </thead> <tbody> <tr> <td>PU (FR-DU07/FR-PU04) setting or external signal input (multi-speed setting, across terminals 4-5 (valid when AU signal turns on)).</td> <td>External signal input (terminal STF, STR)</td> </tr> </tbody> </table>	Running frequency	Start signal	PU (FR-DU07/FR-PU04) setting or external signal input (multi-speed setting, across terminals 4-5 (valid when AU signal turns on)).	External signal input (terminal STF, STR)	 EXT  NET
				Running frequency	Start signal						
			PU (FR-DU07/FR-PU04) setting or external signal input (multi-speed setting, across terminals 4-5 (valid when AU signal turns on)).	External signal input (terminal STF, STR)							
			External/PU combined operation mode 2								
4	Running frequency		<table border="1"> <thead> <tr> <th>Running frequency</th> <th>Start signal</th> </tr> </thead> <tbody> <tr> <td>External signal input (Terminal 2, 4, 1, JOG, multi-speed selection, etc.)</td> <td>Input from the PU (FR-DU07/FR-PU04) (, )</td> </tr> </tbody> </table>	Running frequency	Start signal	External signal input (Terminal 2, 4, 1, JOG, multi-speed selection, etc.)	Input from the PU (FR-DU07/FR-PU04) ( , )	 EXT  NET			
	Running frequency	Start signal									
External signal input (Terminal 2, 4, 1, JOG, multi-speed selection, etc.)	Input from the PU (FR-DU07/FR-PU04) ( , )										
External signal input (Terminal 2, 4, 1, JOG, multi-speed selection, etc.)											
6	Switchover mode Switch among PU operation, external operation, and NET operation while keeping the same operation status.	PU operation mode  PU External operation mode  EXT NET operation mode  NET									
7	External operation mode (PU operation interlock) X12 signal ON* Operation mode can be switched to the PU operation mode. (output stop during external operation) X12 signal OFF* Operation mode can not be switched to the PU operation mode.	PU operation mode  PU External operation mode  EXT									

* For the terminal used for the X12 signal (PU operation interlock signal) input, assign "12" in Pr. 178 to Pr. 189 (input terminal function selection) to assign functions.

For Pr. 178 to Pr. 189, refer to the Instruction Manual (applied).

When the X12 signal is not assigned, function of the MRS signal switches from MRS (output stop) to PU operation interlock signal.

4.7 Parameter clear

POINT

- Set "1" in Pr.CL parameter clear to initialize all parameters. (Parameters are not cleared when "1" is set in Pr. 77 Parameter write selection. In addition, calibration parameters are not cleared.)
- Refer to the extended parameter list on page 107 for parameters to be cleared with this operation.

Operation	Display
1. Screen at powering on The monitor display appears.	
2. Press to choose the PU operation mode.	PU indication is lit.
3. Press to choose the parameter setting mode.	(The parameter number read previously appears.)
4. Turn until "Pr.CL" (parameter clear) appears.	
5. Press to read the currently set value. "0" (initial value) appears.	
6. Turn clockwise to change it to the setting value of "1".	
7. Press to set.	

Flicker ... Parameter setting complete!!

- Turn to read another parameter.
- Press to show the setting again.
- Press twice to show the next parameter.

? and are displayed alternately ... Why?

☞ The inverter is not in the PU operation mode.

1. Press .



is lit and the monitor (4 digit LED) displays "0" (Pr.79 = "0" (initial value)).

2. Carry out operation from step 6 again.



4.8 All parameter clear

POINT

- Set "1" in ALLC parameter clear to initialize all parameters. (Parameters are not cleared when "1" is set in Pr. 77 Parameter write selection. In addition, calibration parameters are not cleared.)
- Refer to the extended parameter list on page 107 for parameters to be cleared with this function.

Operation	Display
1. Screen at powering on The monitor display appears.	
2. Press (PU/EXT) to choose the PU operation mode.	PU indication is lit.
3. Press (MODE) to choose the parameter setting mode.	
4. Turn (rotary knob) until ALLC (all parameter clear) appears.	
5. Press (SET) to read the currently set value. "0" (initial value) appears.	
6. Turn (rotary knob) clockwise to change it to the setting value of "1".	
7. Press (SET) to set.	

Flicker ... Parameter setting complete!!

- Press (rotary knob) to read another parameter.
- Press (SET) to show the setting again.
- Press (SET) twice to show the next parameter.

? are displayed alternately ... Why?

The inverter is not in the PU operation mode.

1. Press (PU/EXT).

is lit and the monitor (4 digit LED) displays "0" (Pr. 79 = "0" (initial value)).

2. Carry out operation from step 6 again.

4.9 Parameter copy

Multiple inverters and parameter settings can be copied.

Operation

- Connect the operation panel to the copy source inverter.
 - **Connect it during a stop.**
- Press **(MODE)** to choose the parameter setting mode.
- Turn **(SEL)** until **PCPY** (parameter copy) appears.
- Press **(SET)** to read the currently set value. "0" (initial value) appears.
- Turn **(SEL)** clockwise to change it to the setting value of "1".
- Press **(SET)** to copy the source parameters to the operation panel.
- Connect the operation panel to the copy source inverter.
- After performing steps 2 to 5, turn **(SEL)** clockwise to change it to "2".
- Press **(SET)** to write the parameters copied to the operation panel to the destination inverter.
- When copy is completed, "2" and "PCPY" flicker.
- After writing the parameter values to the copy destination inverter, always reset the inverter, e.g. switch power off once, before starting operation.

Display

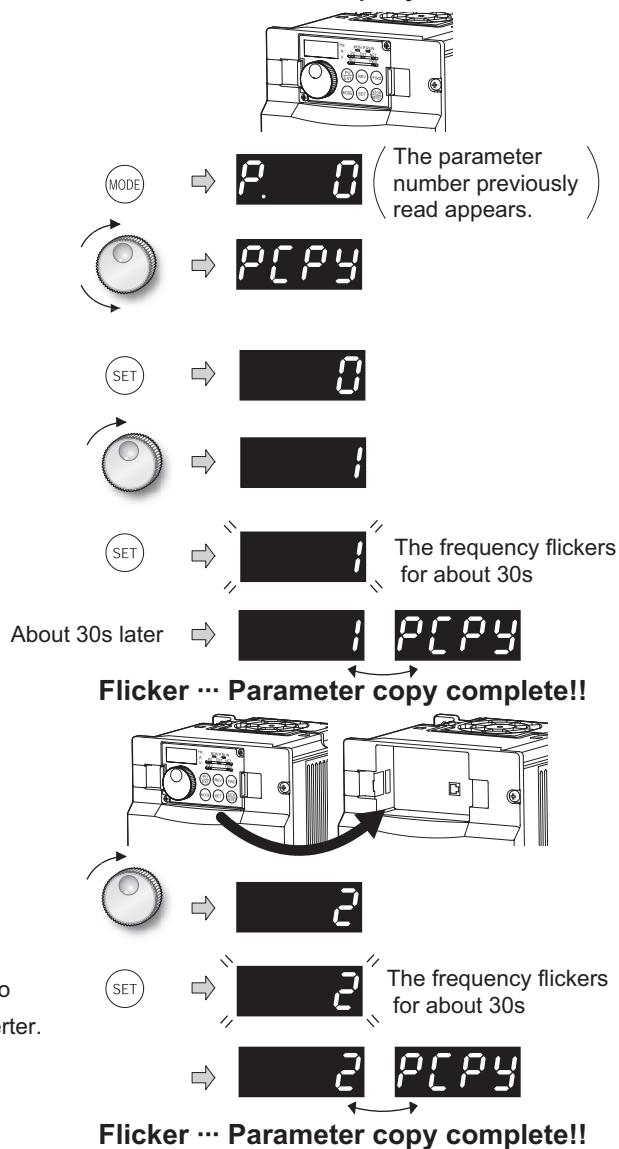

? **rE1** appears...Why? Parameter read error. Perform operation from step 3 again.

? **rE2** appears...Why? Parameter write error. Perform operation from step 8 again.

? **CP** and **000** flicker alternately

Appears when parameters are copied between the inverter of FR-F720-02330 (FR-F740-01160) or less and FR-F720-03160 (FR-F740-01800) or more.

1. Set "0" in Pr. 160 User group read selection.

2. Set the following setting (initial value) in Pr. 989 Parameter copy alarm release.

	FR-F720-02330 (FR-F740-01160) or less	FR-F720-03160 (FR-F740-01800) or more
Pr. 989 Setting	10	100

3. Reset Pr.9, Pr.30, Pr.51, Pr.52, Pr.54, Pr.56, Pr.57, Pr.61, Pr.70, Pr.72, Pr.80, Pr.90, Pr.158, Pr.190 to Pr.196, Pr.893.

PCPY Setting	Description
0	Cancel
1	Copy the source parameters to the operation panel.
2	Write the parameters copied to the operation panel to the destination inverter.
3	Verify parameters in the inverter and operation panel. (Refer to page 62.)

REMARKS

- When the copy destination inverter is not the FR-F700 series, "model error (rE4)" is displayed.
- Refer to the extended parameter list on page 107 for availability of parameter copy.



4.10 Parameter verification

Whether same parameter values are set in other inverters or not can be checked.

Operation	Display
1. Replace the operation panel on the inverter to be verified. • <u>Replace it during a stop.</u>	
2. Screen at powering on The monitor display appears.	
3. Press (MODE) to choose the parameter setting mode.	<p>(The parameter number read previously appears.)</p>
4. Turn (rotary knob) until PCPY (parameter copy) appears.	
5. Press (SET) to read the currently set value. "0" (initial value) appears.	
6. Turn (rotary knob) to change it to the set value of "3" (parameter copy verification mode).	
7. Press (SET) to read the parameter setting of the verified inverter to the operation panel.	<p>The frequency flickers for about 30s</p>
<ul style="list-style-type: none"> • If different parameters exist, different parameter numbers and rE3 flicker. • Hold down (SET) to verify. 	<p>Flickering</p>
8. If there is no difference, PCPY and 3 flicker to complete verification.	<p>Flicker ... Parameter verification complete!!</p>

REMARKS

When the copy destination inverter is not the FR-F700 series, "model error (rE4)" is displayed.

? rE3 flickers ... Why?

☞ Set frequencies, etc. may be different. Check set frequencies.

5 TROUBLESHOOTING

When an alarm occurs in the inverter, the protective function is activated bringing the inverter to an alarm stop and the PU display automatically changes to any of the following error (alarm) indications.

If your fault does not correspond to any of the following errors or if you have any other problem, please contact your sales representative.

- Retention of alarm output signalWhen the magnetic contactor (MC) provided on the input side of the inverter is opened at the activation of the protective function, the inverter's control power will be lost and the alarm output will not be held.
- Alarm displayWhen the protective function is activated, the operation panel display automatically switches to the above indication.
- Resetting method.....When the protective function is activated, the inverter output is kept stopped. Unless reset, therefore, the inverter cannot restart. (Refer to page 75.)
- When the protective function is activated, take the corresponding corrective action, then reset the inverter, and resume operation.

5.1 List of alarm display

Operation Panel Indication		Name	Refer to		
Error message	HOLD	HOLD	Operation panel lock	64	
	Er 1 to Er 4	Er1 to 4	Parameter write error	64	
	rE 1 to rE 4	rE1 to 4	Copy operation error	64	
	Err.	Err.	Error	65	
Warnings	OL	OL	Stall Prevention (overcurrent)	66	
	oL	oL	Stall prevention (overvoltage)	66	
	rb	RB	Regenerative brake prealarm	67	
	TH	TH	Electronic thermal relay function prealarm	67	
	PS	PS	PU Stop	66	
	MT	MT	Maintenance signal output	67	
	CP	CP	Parameter copy	67	
Minor fault	Fn	FN	Fan fault	67	
Major failures	E.OC 1	E.OC1	Overcurrent shut-off during acceleration	68	
	E.OC 2	E.OC2	Overcurrent shut-off during constant speed	68	
	E.OC 3	E.OC3	Overcurrent shut-off during deceleration or stop	68	
	E.OV 1	E.OV1	Regenerative overvoltage shut-off during acceleration	68	
	E.OV 2	E.OV2	Regenerative overvoltage shut-off during constant speed	69	
	E.OV 3	E.OV3	Regenerative overvoltage shut-off during deceleration or stop	69	
	E.THT	E.THT	Inverter overload shut-off (electronic thermal relay function)	69	
	E.THM	E.THM	Motor overload shut-off (electronic thermal relay function)	69	
	E.FIN	E.FIN	Fin overheat	70	
	E.IPF	E.IPF	Instantaneous power failure protection	70	
	E.UVT	E.UVT	Undervoltage protection	70	
	Major failures	E.ILF	E.ILF*	Input phase failure	70
		E.OLT	E.OLT	Stall Prevention	71
		E.GF	E.GF	Output side ground fault overcurrent protection	71
E.LF		E.LF	Output phase failure protection	71	
E.OHT		E.OHT	External thermal relay operation ²	71	
E.PTC		E.PTC*	PTC thermistor operation	71	
E.OPT		E.OPT	Option alarm	71	
E.OP 1		E.OP1	Option slot alarm (e.g.communication error)	72	
E. 1		E. 1	Option alarm (e.g.connection or contact fault)	72	
E. PE		E.PE	Parameter storage device alarm	72	
E.PUE		E.PUE	PU disconnection	72	
E.RET		E.RET	Retry count excess	72	
E.PE2		E.PE2*	Parameter storage device alarm	72	
E. 6 / E. 7 / E.CPU		E. 6 / E. 7 / E.CPU	CPU error	73	
E.CTE	E.CTE	Operation panel power supply short circuit RS-485 terminals power supply short circuit	73		
E.P24	E.P24	24VDC power output short circuit	73		
E.CDO	E.CDO*	Output current detection value exceeded	73		
E.IOH	E.IOH*	Inrush resistor overheat	73		
E.SER	E.SER*	Communication error (inverter)	74		
E.AIE	E.AIE*	Analog input error	74		
E. BE	E.BE	Brake transistor alarm detection/internal circuit error	70		
E. 13	E.13*	Internal circuit error	74		



* If an error occurs when using the FR-PU04, "Fault 14" is displayed on the FR-PU04.



5.2 Causes and corrective actions

(1) Error Message

A message regarding operational troubles is displayed. Output is not shut off.

Operation Panel Indication	HOLD	HOLD
Name	Operation panel lock	
Description	Operation lock mode is set. Operation other than  is made invalid. (Refer to page 31.)	
Check point	—	
Corrective action	Press  for 2s to release lock.	

Operation Panel Indication	Er1	Er1
Name	Write disable error	
Description	<ol style="list-style-type: none"> 1. You attempted to make parameter setting when Pr. 77 Parameter write selection has been set to disable parameter write. 2. Frequency jump setting range overlapped. 3. Adjustable 5 points V/F settings overlapped 4. The PU and inverter cannot make normal communication 	
Check point	<ol style="list-style-type: none"> 1. Check the setting of Pr. 77 Parameter write selection (Refer to the Instruction Manual (applied).) 2. Check the settings of Pr. 31 to 36 (frequency jump). (Refer to the Instruction Manual (applied).) 3. Check the settings of Pr. 100 to Pr. 109 (Adjustable 5 points V/F). (Refer to the Instruction Manual (applied).) 4. Check the connection of the PU and inverter. 	

Operation Panel Indication	Er2	Er2
Name	Write error during operation	
Description	When parameter write was performed during operation with a value other than "2" (writing is enabled independently of operation status in any operation mode) is set in Pr. 77 and the STF (STR) is on.	
Check point	<ol style="list-style-type: none"> 1. Check the Pr. 77 setting. (Refer to the Instruction Manual (applied).) 2. Check that the inverter is not operating. 	
Corrective action	<ol style="list-style-type: none"> 1. Set "2" in Pr. 72. 2. After stopping operation, make parameter setting. 	

Operation Panel Indication	Er3	Er3
Name	Calibration error	
Description	Analog input bias and gain calibration values are too close.	
Check point	Check the settings of C3, C4, C6 and C7 (calibration functions). (Refer to the Instruction Manual (applied).)	

Operation Panel Indication	Er4	Er4
Name	Mode designation error	
Description	You attempted to make parameter setting in the NET operation mode when Pr. 77 is not "2".	
Check point	<ol style="list-style-type: none"> 1. Check that operation mode is "PU operation mode". 2. Check the Pr. 77 setting. (Refer to the Instruction Manual (applied).) 	
Corrective action	<ol style="list-style-type: none"> 1. After setting the operation mode to the "PU operation mode", make parameter setting. (Refer to page 58.) 2. After setting "2" in Pr. 77, make parameter setting. 	

Operation Panel Indication	rE1	rE1
Name	Parameter read error	
Description	An error occurred in the EEPROM on the operation panel side during parameter copy reading.	
Check point	—	
Corrective action	<ul style="list-style-type: none"> · Make parameter copy again. (Refer to page 61.) · Check for an operation panel (FR-DU07) failure. Please contact your sales representative. 	

Operation Panel Indication	rE2	rE2
Name	Parameter write error	
Description	1. You attempted to perform parameter copy write during operation. 2. An error occurred in the EEPROM on the operation panel side during parameter copy writing.	
Check point	Is the FWD or REV LED of the operation panel (FR-DU07) lit or flickering?	
Corrective action	1. After stopping operation, make parameter copy again. (Refer to page 61.) 2. Check for an operation panel (FR-DU07) failure. Please contact your sales representative.	

Operation Panel Indication	rE3	rE3
Name	Parameter verification error	
Description	1. Data on the operation panel side and inverter side are different. 2. An error occurred in the EEPROM on the operation panel side during parameter verification.	
Check point	Check for the parameter setting of the source inverter and inverter to be verified.	
Corrective action	1. Press  to continue verification. Make parameter verification again. (Refer to page 62.) 2. Check for an operation panel (FR-DU07) failure. Please contact your sales representative.	

Operation Panel Indication	rE4	rE4
Name	Model error	
Description	A different model was used for parameter write and verification during parameter copy.	
Check point	Check that the verified inverter is the same model.	
Corrective action	Use the same model (FR-F700 series) for parameter copy and verification.	

Operation Panel Indication	Err.	Err.
Description	1. The RES signal is on; 2. The PU and inverter cannot make normal communication (contact fault of the connector)	
Corrective action	1. Turn off the RES signal. 2. Check the connection of the PU and inverter.	



(2) Warnings

When the protective function is activated, the output is not shut off.

Operation Panel Indication	OL		FR-PU04	OL
Name	Stall prevention (overcurrent)			
Description	During acceleration	If a current of more than 110%*1 of the rated inverter current flows in the motor, this function stops the increase in frequency until the overload current reduces to prevent the inverter from resulting in overcurrent shut-off. When the overload current has reduced below 110%*1, this function increases the frequency again.		
	During constant-speed operation	If a current of more than 110%*1 of the rated inverter current flows in the motor, this function lowers the frequency until the overload current reduces to prevent overcurrent shut-off. When the overload current has reduced below 110%*1, this function increases the frequency up to the set value.		
	During deceleration	If a current of more than 110%*1 of the rated inverter current flows in the motor, this function stops the decrease in frequency until the overload current reduces to prevent the inverter from resulting in overcurrent shut-off. When the overload current has reduced below 110%*1, this function decreases the frequency again.		
Check point	1. Check that the <i>Pr. 0 Torque boost</i> setting is not too large. 2. Check that the <i>Pr. 7 Acceleration time</i> and <i>Pr. 8 Deceleration time</i> settings are not too small. 3. Check that the load is not too heavy. 4. Are there any failure in peripheral devices? 5. Check that the <i>Pr. 13 Starting frequency</i> is not too large. · Check the motor for use under overload.			
Corrective action	1. Increase or decrease the <i>Pr. 0 Torque boost</i> value 1% by 1% and check the motor status. (Refer to page 53.) 2. Set a larger value in <i>Pr. 7 Acceleration time</i> and <i>Pr. 8 Deceleration time</i> . (Refer to page 55.) 3. Reduce the load weight. 4. Try simple magnetic flux vector control (<i>Pr. 80</i>). 5. Change the <i>Pr. 14 Load pattern selection</i> setting. 6. Set stall prevention operation current in <i>Pr. 22 Stall prevention operation level</i> . (The initial value is 110%.) The acceleration/deceleration time may change. Increase the stall prevention operation level with <i>Pr. 22 Stall prevention operation level</i> , or disable stall prevention with <i>Pr. 156 Stall prevention operation selection</i> . (Use <i>Pr. 156</i> to set either operation continued or not at OL operation.)			

*1 120% when LD is selected

Operation Panel Indication	oL		FR-PU04	oL
Name	Stall prevention (overvoltage)			
Description	During deceleration	<ul style="list-style-type: none"> If the regenerative energy of the motor becomes excessive and exceeds the regenerative energy consumption capability, this function stops the decrease in frequency to prevent overvoltage shut-off. As soon as the regenerative energy has reduced, deceleration resumes. If the regenerative energy of the motor becomes excessive when regeneration avoidance function is selected (<i>Pr. 882 = 1</i>), this function increases the speed to prevent overvoltage shut-off. (Refer to the Instruction Manual (applied).) 		
		<ul style="list-style-type: none"> Check for sudden speed reduction. Regeneration avoidance function (<i>Pr. 882 to Pr. 886</i>) is being used? (Refer to the Instruction Manual (applied).) 		
Check point				
Corrective action	The deceleration time may change. Increase the deceleration time using <i>Pr. 8 Deceleration time</i> .			

Operation Panel Indication	PS		FR-PU04	PS
Name	PU Stop			
Description	Stop with of the PU is set in <i>Pr. 75 Reset selection/disconnected PU detection/PU stop selection</i> . (For <i>Pr. 75</i> , refer to the Instruction Manual (applied).)			
Check point	Check for a stop made by pressing of the operation panel.			
Corrective action	Turn the start signal off and release with .			



Operation Panel Indication	RB	<i>rb</i>	FR-PU04	RB
Name	Regenerative brake prealarm			
Description	Appears if the regenerative brake duty reaches or exceeds 85% of the <i>Pr. 70 Special regenerative brake duty</i> value. If the regenerative brake duty reaches 100%, a regenerative overvoltage (E. OV_) occurs. Appears only for the FR-F720-03160 (FR-F740-01800) or more.			
Check point	<ul style="list-style-type: none"> • Check that the brake resistor duty is not high. • Check that the <i>Pr. 30 Regenerative function selection</i> and <i>Pr. 70 Special regenerative brake duty</i> values are correct. 			
Corrective action	<ul style="list-style-type: none"> • Increase the deceleration time. • Check the <i>Pr. 30 Regenerative function selection</i> and <i>Pr. 70 Special regenerative brake duty</i> values. 			

Operation Panel Indication	TH	<i>TH</i>	FR-PU04	TH
Name	Electronic thermal relay function prealarm			
Description	Appears if the integrating value of the <i>Pr. 9 Electronic thermal O/L relay</i> reaches or exceeds 85% of the preset level. If it reaches 100% of the <i>Pr. 9 Electronic thermal O/L relay</i> setting, a motor overload shut-off (E. THM) occurs.			
Check point	<ol style="list-style-type: none"> 1. Check for large load or sudden acceleration. 2. Is the <i>Pr. 9 Electronic thermal O/L relay</i> setting is appropriate? (Refer to page 33.) 			
Corrective action	<ol style="list-style-type: none"> 1. Reduce the load weight or the number of operation times. 2. Set an appropriate value in <i>Pr. 9 Electronic thermal O/L relay</i>. (Refer to page 33.) 			

Operation Panel Indication	MT	<i>MT</i>	FR-PU04	——
Name	Maintenance signal output			
Description	Indicates that the cumulative energization time of the inverter has reached a given time.			
Check point	The <i>Pr. 503 Maintenance timer</i> setting is larger than the <i>Pr. 504 Maintenance timer alarm output set time</i> setting. (Refer to the Instruction Manual (applied).)			
Corrective action	Setting "0" in <i>Pr. 503 Maintenance timer</i> erases the signal.			

Operation Panel Indication	CP	<i>CP</i>	FR-PU04	——
Name	Parameter copy			
Description	Appears when parameters are copied between models with capacities of FR-F720-02330 (FR-F740-01160) or less and FR-F720-03160 (FR-F740-01800) or more.			
Check point	Resetting of <i>Pr.9, Pr.30, Pr.51, Pr.52, Pr.54, Pr.56, Pr.57, Pr.61, Pr.70, Pr.72, Pr.80, Pr.90, Pr.158, Pr.190 to Pr.196, and Pr.893</i> is necessary.			
Corrective action	Set the initial value in <i>Pr. 989 Parameter copy alarm release</i> .			

(3) Minor fault

When the protective function is activated, the output is not shut off. You can also output a minor fault signal by making parameter setting. (Set "98" in any of *Pr. 190 to Pr. 196 (output terminal function selection)*. (Refer to the Instruction Manual (applied).))

Operation Panel Indication	FN	<i>F_n</i>	FR-PU04	FN
Name	Fan fault			
Description	For the inverter that contains a cooling fan, <i>F_n</i> appears on the operation panel when the cooling fan stops due to a fault or different operation from the setting of <i>Pr. 244 Cooling fan operation selection</i> .			
Check point	Check the cooling fan for a fault.			
Corrective action	Check for fan fault. Please contact your sales representative.			



(4) Major fault

When the protective function is activated, the inverter output is shut off and an alarm is output.

Operation Panel Indication	E.OC1	E.OC1	FR-PU04	OC During Accs
Name	Overcurrent shut-off during acceleration			
Description	When the inverter output current reaches or exceeds approximately 170% of the rated current during acceleration, the protective circuit is activated to stop the inverter output.			
Check point	<ol style="list-style-type: none"> 1. Check for sudden acceleration. 2. Check that the downward acceleration time is not long in vertical lift application. 3. Check for output short circuit. 4. Check that the <i>Pr. 3 Base frequency</i> setting is not 60Hz when the motor rated frequency is 50Hz. 5. Check that stall prevention operation is correct 6. Check that the regeneration is not performed frequently. (Check that the output voltage becomes larger than the V/F reference voltage at regeneration and overcurrent due to increase in motor current occurs.) 			
Corrective action	<ol style="list-style-type: none"> 1. Increase the acceleration time. (Shorten the downward acceleration time in vertical lift application.) 2. When "E.OC1" is always lit at starting, disconnect the motor once and start the inverter. If "E.OC1" is still lit, contact your sales representative. 3. Check the wiring to avoid output short circuit. 4. Set the <i>Pr. 3 Base frequency</i> to 50Hz. (Refer to page 34.) 5. Perform a correct stall prevention operation. (Refer to the <i>Instruction Manual (applied)</i>.) 6. Set base voltage (rated voltage of the motor, etc.) in <i>Pr. 19 Base frequency voltage</i>. (Refer to the <i>Instruction Manual (applied)</i>.) 			

Operation Panel Indication	E.OC2	E.OC2	FR-PU04	Stedy Spd OC
Name	Overcurrent shut-off during constant speed			
Description	When the inverter output current reaches or exceeds approximately 170% of the rated current during constant speed operation, the protective circuit is activated to stop the inverter output.			
Check point	<ol style="list-style-type: none"> 1. Check for sudden load change. 2. Check for output short circuit. 3. Check that stall prevention operation is correct 			
Corrective action	<ol style="list-style-type: none"> 1. Keep load stable. 2. Check the wiring to avoid output short circuit. 3. Check that stall prevention operation setting is correct. (Refer to the <i>Instruction Manual (applied)</i>.) 			

Operation Panel Indication	E.OC3	E.OC3	FR-PU04	OC During Dec
Name	Overcurrent shut-off during deceleration or stop			
Description	When the inverter output current reaches or exceeds approximately 170% of the rated inverter current during deceleration (other than acceleration or constant speed), the protective circuit is activated to stop the inverter output.			
Check point	<ol style="list-style-type: none"> 1. Check for sudden speed reduction. 2. Check for output short circuit. 3. Check for too fast operation of the motor's mechanical brake. 4. Check that stall prevention operation setting is correct. 			
Corrective action	<ol style="list-style-type: none"> 1. Increase the deceleration time. 2. Check the wiring to avoid output short circuit. 3. Check the mechanical brake operation. 4. Check that stall prevention operation setting is correct. (Refer to the <i>Instruction Manual (applied)</i>.) 			

Operation Panel Indication	E.OV1	E.OV1	FR-PU04	OV During Acc
Name	Regenerative overvoltage shutoff during acceleration			
Description	If regenerative energy causes the inverter's internal main circuit DC voltage to reach or exceed the specified value, the protective circuit is activated to stop the inverter output. The circuit may also be activated by a surge voltage produced in the power supply system.			
Check point	Check for too slow acceleration. (e.g. during descending acceleration with lifting load)			
Corrective action	<ul style="list-style-type: none"> · Decrease the acceleration time. · Use regeneration avoidance function (<i>Pr. 882 to Pr. 886</i>). (Refer to the <i>Instruction Manual (applied)</i>.) 			



Operation Panel Indication	E.OV2	<i>E.Ov2</i>	FR-PU04	Stedy Spd OV
Name	Regenerative overvoltage shut-off during constant speed			
Description	If regenerative energy causes the inverter's internal main circuit DC voltage to reach or exceed the specified value, the protective circuit is activated to stop the inverter output. The circuit may also be activated by a surge voltage produced in the power supply system.			
Check point	Check for sudden load change.			
Corrective action	<ul style="list-style-type: none"> · Keep load stable. · Use regeneration avoidance function (Pr. 882 to Pr. 886). (Refer to the Instruction Manual (applied).) · Use the brake unit or power regeneration common converter (FR-CV) as required. 			

Operation Panel Indication	E.OV3	<i>E.Ov3</i>	FR-PU04	OV During Dec
Name	Regenerative overvoltage shut-off during deceleration or stop			
Description	If regenerative energy causes the inverter's internal main circuit DC voltage to reach or exceed the specified value, the protective circuit is activated to stop the inverter output. The circuit may also be activated by a surge voltage produced in the power supply system.			
Check point	Check for sudden speed reduction.			
Corrective action	<ul style="list-style-type: none"> · Increase the deceleration time. (Set the deceleration time which matches the inertia of moment of the load) · Decrease the braking duty. · Use regeneration avoidance function (Pr. 882 to Pr. 886). (Refer to the Instruction Manual (applied).) · Use the brake unit or power regeneration common converter (FR-CV) as required. 			

Operation Panel Indication	E.THT	<i>E.THT</i>	FR-PU04	Inv. Overload
Name	Inverter overload shut-off (electronic thermal relay function) ^{*3}			
Description	If a current not less than 110% ^{*2} of the rated output current flows and overcurrent shut-off does not occur (170% or less), inverse-time characteristics cause the electronic thermal relay to be activated to stop the inverter output in order to protect the output transistors. (overload immunity 110% ^{*2} 60s)			
Check point	Check the motor for use under overload.			
Corrective action	Reduce the load weight.			

*2 120% when LD is selected

Operation Panel Indication	E.THM	<i>E.THM</i>	FR-PU04	Motor Ovrload
Name	Motor overload shut-off (electronic thermal relay function) ^{*3}			
Description	The electronic thermal relay function in the inverter detects motor overheat due to overload or reduced cooling capability during constant-speed operation and pre-alarm (TH display) is output when the temperature reaches 85% of the Pr. 9 <i>Electronic thermal O/L relay</i> setting and the protection circuit is activated to stop the inverter output when the temperature reaches the specified value. When running a special motor such as a multi-pole motor or multiple motors, provide a thermal relay on the inverter output side since such motor(s) cannot be protected by the electronic thermal relay function.			
Check point	<ol style="list-style-type: none"> 1. Check the motor for use under overload. 2. Check that the setting of Pr. 71 <i>Applied motor</i> for motor selection is correct. (Refer to the Instruction Manual (applied).) 3. Check that stall prevention operation setting is correct. 			
Corrective action	<ol style="list-style-type: none"> 1. Reduce the load weight. 2. For a constant-torque motor, set the constant-torque motor in Pr. 71 <i>Applied motor</i>. 3. Check that stall prevention operation setting is correct. (Refer to the Instruction Manual (applied).) 			

*3 Resetting the inverter initializes the internal thermal integrated data of the electronic thermal relay function.



Operation Panel Indication	E.FIN	E.FIN	FR-PU04	H/Sink O/Temp
Name	Fin overheat			
Description	If the heatsink overheats, the temperature sensor is actuated to stop the inverter output.			
Check point	1. Check for too high ambient temperature. 2. Check for heatsink clogging.			
Corrective action	1. Set the ambient temperature to within the specifications. 2. Clean the heatsink.			

Operation Panel Indication	E.IPF	E.IPF	FR-PU04	Inst. Pwr. Loss
Name	Instantaneous power failure protection			
Description	If a power failure occurs for longer than 15ms (this also applies to inverter input shut-off), the instantaneous power failure protective function is activated to stop the inverter output in order to prevent the control circuit from malfunctioning. If a power failure persists for longer than 100ms, the alarm warning output is not provided, and the inverter restarts if the start signal is on upon power restoration. (The inverter continues operating if an instantaneous power failure is within 15ms.) In some operating status (load magnitude, acceleration/deceleration time setting, etc.), overcurrent or other protection may be activated upon power restoration.			
Check point	Find the cause of instantaneous power failure occurrence.			
Corrective action	<ul style="list-style-type: none"> · Remedy the instantaneous power failure. · Prepare a backup power supply for instantaneous power failure. · Set the function of automatic restart after instantaneous power failure (Pr. 57). (Refer to the Instruction Manual (applied).) 			

Operation Panel Indication	E.BE	E. bE	FR-PU04	Br. Cct. Fault
Name	Brake transistor alarm detection			
Description	This function stops the inverter output if an alarm occurs in the brake circuit, e.g. damaged brake transistors when using functions of the FR-F720-03160 (FR-F740-01800) or more. <u>In this case, the inverter must be powered off immediately.</u> For the FR-F720-02330 (FR-F740-01160) or less, it appears when an internal circuit error occurred.			
Check point	<ul style="list-style-type: none"> · Reduce the load inertia. · Check that the frequency of using the brake is proper. · Check that the brake resistor selected is correct. 			
Corrective action	For the FR-F720-03160 (FR-F740-01800) or more, when the protective function is activated even if the above measures are taken, replace the brake unit with a new one. For the FR-F720-02330 (FR-F740-01160) or less, replace the inverter.			

Operation Panel Indication	E.UVT	E.UVT	FR-PU04	Under Voltage
Name	Undervoltage protection			
Description	If the power supply voltage of the inverter reduces, the control circuit will not perform normal functions. In addition, the motor torque will be insufficient and/or heat generation will increase. To prevent this, if the power supply voltage reduces below about 150V (300VAC for the 400V class), this function stops the inverter output. When a jumper is not connected across P/+P1, the undervoltage protective function is activated.			
Check point	1. Check for start of large-capacity motor. 2. Check that a jumper or DC reactor is connected across terminals P/+P1.			
Corrective action	1. Check the power supply system equipment such as the power supply. 2. Connect a jumper or DC reactor across terminals P/+P1. 3. If the problem still persists after taking the above measure, please contact your sales representative.			

Operation Panel Indication	E.ILF	E.ILF	FR-PU04	Fault 14
Name	Input phase failure			
Description	This alarm is output when function valid setting (=1) is set in Pr.872 Input phase failure protection selection and one phase of the three phase power input opens. (Refer to the Instruction Manual (applied).)			
Check point	Check for a break in the cable for the three-phase power supply input.			
Corrective action	<ul style="list-style-type: none"> · Wire the cables properly. · Repair a brake portion in the cable. · Check the Pr. 872 Input phase failure protection selection setting. 			



Operation Panel Indication	E.OLT	<i>E.OLT</i>	FR-PU04	Still Prev STP (OL shown during stall prevention operation)
Name	Stall prevention			
Description	If the frequency has fallen to 0.5Hz by stall prevention operation and remains for 3s, an alarm (E.OLT) appears to shutoff the inverter output. OL appears while stall prevention is being activated.			
Check point	· Check the motor for use under overload. (Refer to the Instruction Manual (applied).)			
Corrective action	· Reduce the load weight.			

Operation Panel Indication	E.GF	<i>E. GF</i>	FR-PU04	Ground Fault
Name	Output side ground fault overcurrent protection			
Description	This function stops the inverter output if a ground fault overcurrent flows due to an ground fault that occurred on the inverter's output (load) side.			
Check point	Check for a ground fault in the motor and connection cable.			
Corrective action	Remedy the ground fault portion.			

Operation Panel Indication	E.LF	<i>E. LF</i>	FR-PU04	—
Name	Output phase failure protection			
Description	This function stops the inverter output if one of the three phases (U, V, W) on the inverter's output side (load side) opens.			
Check point	· Check the wiring (Check that the motor is normal.) · Check that the capacity of the motor used is not smaller than that of the inverter.			
Corrective action	· Wire the cables properly. · Check the Pr. 251 Output phase failure protection selection setting.			

Operation Panel Indication	E.OHT	<i>E.OHT</i>	FR-PU04	OH Fault
Name	External thermal relay operation *4			
Description	If the external thermal relay provided for motor overheat protection, or the internally mounted temperature relay in the motor, etc. switches on (contacts open), the inverter output is stopped.			
Check point	· Check for motor overheating. · Check that the value of 7 (OH signal) is set correctly in any of Pr. 178 to Pr. 189 (input terminal function selection).			
Corrective action	· Reduce the load and operating duty. · Even if the relay contacts are reset automatically, the inverter will not restart unless it is reset.			

*4 Functions only when any of Pr. 178 to Pr. 189 (input terminal function selection) is set to OH.

Operation Panel Indication	E.PTC	<i>E.PTC</i>	FR-PU04	Fault 14
Name	PTC thermistor operation			
Description	Appears when the motor overheat status is detected for 10s or more by the external PTC thermistor input connected to the terminal AU.			
Check point	· Check the connection between the PTC thermistor switch and thermal protector. · Check the motor for operation under overload. · Is valid setting (=63) selected in Pr. 184 AU terminal function selection ? (Refer to the Instruction Manual (applied).)			
Corrective action	Reduce the load weight.			

Operation Panel Indication	E.OPT	<i>E.OPT</i>	FR-PU04	Option Fault
Name	Option alarm			
Description	Appears when the AC power supply is connected to the terminal R/L1, S/L2, T/L3 accidentally when a high power factor converter is connected.			
Check point	· Check that the AC power supply is not connected to the terminal R/L1, S/L2, T/L3 when a high power factor converter (FR-HC, MT-HC) or power regenerative common converter (FR-CV) is connected.			
Corrective action	· Check the parameter (Pr. 30) setting and wiring. · The inverter may be damaged if the AC power supply is connected to the terminal R/L1, S/L2, T/L3 when a high power factor converter is connected. Please contact your sales representative.			



Operation Panel Indication	E.OP1	E.O P 1	FR-PU04	Option slot alarm 1
Name	Option slot alarm (e.g.communication error)			
Description	Stops the inverter output if a functional error (e.g. communication line error of the communication option or contact fault of the plug-in option other than the communication option) occurs in the plug-in option fitted to the option slot.			
Check point	<ul style="list-style-type: none"> · Check for a wrong option function setting and operation. · Check that the plug-in option is plugged into the connector securely. · Check for a brake in the communication cable. · Check that the terminating resistor is fitted properly. · Check that the option card is normal. 			
Corrective action	<ul style="list-style-type: none"> · Check the option function setting, etc. · Connect the plug-in option securely. 			

Operation Panel Indication	E. 1	E. 1	FR-PU04	Fault 1
Name	Option alarm (e.g.connection or contact fault)			
Description	Stops the inverter output if a contact fault or the like of the connector between the inverter and communication option occurs.			
Check point	<ol style="list-style-type: none"> 1. Check that the plug-in option is plugged into the connector securely. 2. Check for excess electrical noises around the inverter. 			
Corrective action	<ol style="list-style-type: none"> 1. Connect the plug-in option securely. 2. Take measures against noises if there are devices producing excess electrical noises around the inverter. If the problem still persists after taking the above measure, please contact your sales representative or distributor. 			

Operation Panel Indication	E.PE	E. PE	FR-PU04	Corrupt Memry
Name	Parameter storage device alarm (control circuit board)			
Description	A fault occurred in parameters stored (EEPROM failure)			
Check point	Check for too many number of parameter write times.			
Corrective action	<p>Please contact your sales representative.</p> <p>When performing parameter write frequently for communication purposes, set "1" in <i>Pr. 342</i> to enable RAM write. Note that powering off returns the inverter to the status before RAM write.</p>			

Operation Panel Indication	E.PE2	E.PE2	FR-PU04	Fault 14
Name	Parameter storage device alarm (main circuit board)			
Description	A fault occurred in parameters stored (EEPROM failure)			
Check point	_____			
Corrective action	Please contact your sales representative.			

Operation Panel Indication	E.PUE	E.PUE	FR-PU04	PU Leave Out
Name	PU disconnected			
Description	This function stops the inverter output if communication between the inverter and PU is suspended, e.g. the operation panel and parameter unit is disconnected, when "2", "3", "16" or "17" was set in <i>Pr. 75 Reset selection/disconnected PU detection/PU stop selection</i> . This function stops the inverter output when communication errors occurred consecutively for more than permissible number of retries when a value other than "9999" is set in <i>Pr. 121 Number of PU communication retries</i> during the RS-485 communication with the PU connector. This function also stops the inverter output if communication is broken for the period of time set in <i>Pr. 122 PU communication check time interval</i> .			
Check point	<ul style="list-style-type: none"> · Check that the FR-DU07 or parameter unit (FR-PU04) is fitted tightly. · Check the <i>Pr. 75</i> setting. 			
Corrective action	Fit the FR-DU07 or parameter unit (FR-PU04) securely.			

Operation Panel Indication	E.RET	E.r ET	FR-PU04	Retry No Over
Name	Retry count excess			
Description	If operation cannot be resumed properly within the number of retries set, this function stops the inverter output.			
Check point	Find the cause of alarm occurrence.			
Corrective action	Eliminate the cause of the error preceding this error indication.			



Operation Panel Indication	E. 6	E. 6	FR-PU04	Fault 6
	E. 7	E. 7		Fault 7
	E.CPU	E.CPU		CPU Fault
Name	CPU fault			
Description	Stops the inverter output if the communication error of the built-in CPU occurs.			
Check point	Check for devices producing excess electrical noises around the inverter.			
Corrective action	<ul style="list-style-type: none"> Take measures against noises if there are devices producing excess electrical noises around the inverter. Please contact your sales representative. 			

Operation Panel Indication	E.CTE	E.CTE	FR-PU04	—
Name	Operation panel power supply short circuit, RS-485 terminal power supply short circuit			
Description	<p>When the operation panel power supply (PU connector) is shorted, this function shuts off the power output. At this time, the operation panel (parameter unit) cannot be used and RS-485 communication from the PU connector cannot be made. When the power supply for the RS-485 terminals are shorted, this function shuts off the power output.</p> <p>At this time, communication from the RS-485 terminals cannot be made.</p> <p>To reset, enter the RES signal or switch power off, then on again.</p>			
Check point	<ol style="list-style-type: none"> Check for a short circuit in the PU connector cable. Check that the RS-485 terminals are connected correctly. 			
Corrective action	<ol style="list-style-type: none"> Check the PU and cable. Check the connection of the RS-485 terminals 			

Operation Panel Indication	E.P24	E.P24	FR-PU04	E.P24
Name	24VDC power output short circuit			
Description	<p>When the 24VDC power output from the PC terminal is shorted, this function shuts off the power output. At this time, all external contact inputs switch off. The inverter cannot be reset by entering the RES signal. To reset it, use the operation panel or switch power off, then on again.</p>			
Check point	<ul style="list-style-type: none"> Check for a short circuit in the PC terminal output. 			
Corrective action	<ul style="list-style-type: none"> Remedy the ground fault portion. 			

Operation Panel Indication	E.CDO	E.CDO	FR-PU04	Fault 14
Name	Output current detection value excess			
Description	This function is activated when the output current exceeds the <i>Pr. 150 Output current detection level</i> setting.			
Check point	Check the settings of <i>Pr. 150 Output current detection level</i> , <i>Pr. 151 Output current detection signal delay time</i> , <i>Pr. 166 Output current detection signal retention time</i> , <i>Pr. 167 Output current detection operation selection</i> . (Refer to the Instruction Manual (applied).)			

Operation Panel Indication	E.IOH	E.IOH	FR-PU04	Fault 14
Name	Inrush resistance overheat			
Description	This function is activated when the resistor of the inrush current limit circuit overheats.			
Check point	<ol style="list-style-type: none"> Check that the inrush current is not large. Check that frequent ON/OFF is not repeated in the circuit which starts upon powering on. 			
Corrective action	<ol style="list-style-type: none"> The inrush current limit circuit failure Configure a circuit where frequent ON/OFF is not repeated. <p>If the problem still persists after taking the above measure, please contact your sales representative.</p>			



Operation Panel Indication	E.SER	E.SEr	FR-PU04	Fault 14
Name	Communication error (inverter)			
Description	This function stops the inverter output when communication error occurs consecutively for more than permissible retry count when a value other than "9999" is set in <i>Pr. 335 RS-485 communication number of retries</i> during RS-485 communication from the RS-485 terminals. This function also stops the inverter output if communication is broken for the period of time set in <i>Pr. 336 RS-485 communication check time interval</i> .			
Check point	Check the RS-485 terminal wiring.			
Corrective action	Perform wiring of the RS-485 terminals properly.			

Operation Panel Indication	E.AIE	E.AIE	FR-PU04	Fault 14
Name	Analog input error			
Description	Appears when 30mA or more is input or a voltage (7.5V or more) is input with the terminal 2/4 set to current input.			
Check point	Check the setting of <i>Pr. 73 Analog input selection</i> and <i>Pr. 267 Terminal 4 input selection</i> . (Refer to the <i>Instruction Manual (applied)</i> .)			
Corrective action	Either give a frequency command by current input or set <i>Pr. 73 Analog input selection</i> or <i>Pr. 267 Terminal 4 input selection</i> to voltage input. (Refer to the <i>Instruction Manual (applied)</i> .)			

Operation Panel Indication	E.13	E. 13	FR-PU07	Fault 14
Name	Internal circuit error			
Description	Appears when an internal circuit error occurred.			
Corrective action	Please contact your sales representative.			

CAUTION

- If protective functions of E.ILF, E.PTC, E.PE2, E.CDO, E.IOH, E.SER, E.AIE, E.13 are activated when using the FR-PU04, "Fault 14" appears.
Also when the alarm history is checked on the FR-PU04, the display is "E.14".
- If alarms other than the above appear, contact your sales representative.

5.3 Reset method of protective function

(1) Resetting the inverter

The inverter can be reset by performing any of the following operations. Note that the internal thermal integrated value of the electronic thermal relay function and the number of retries are cleared (erased) by resetting the inverter. It takes about 1s for reset.

Operation 1: Using the operation panel, press  to reset the inverter.

(Enabled only when the inverter protective function is activated (major fault) (Refer to *page 68* for major fault.))

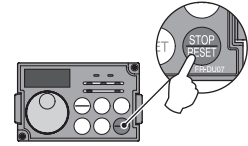

Operation 2:..... Switch power off once, then switch it on again.

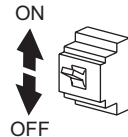

Operation 3: Turn on the reset signal (RES) for more than 0.1s. (If the RES signal is kept on, "Err." appears (flickers) to indicate that the inverter is in a reset status.)

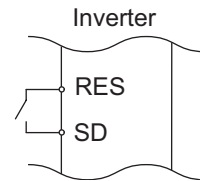

5.4 Correspondences between digital and actual characters

There are the following correspondences between the actual alphanumeric characters and the digital characters displayed on the operation panel.

Actual	Digital
0	0
1	1
2	2
3	3
4	4
5	5
6	6
7	7
8	8
9	9

Actual	Digital
A	A
B	b
C	C
D	d
E	E
F	F
G	G
H	H
I	I
J	J
L	L

Actual	Digital
M	M
N	n
O	O
o	o
P	P
S	S
T	T
U	U
V	V
r	r
-	-

5.5 Check and clear of the alarm history

(1) Check for the alarm (major fault) history

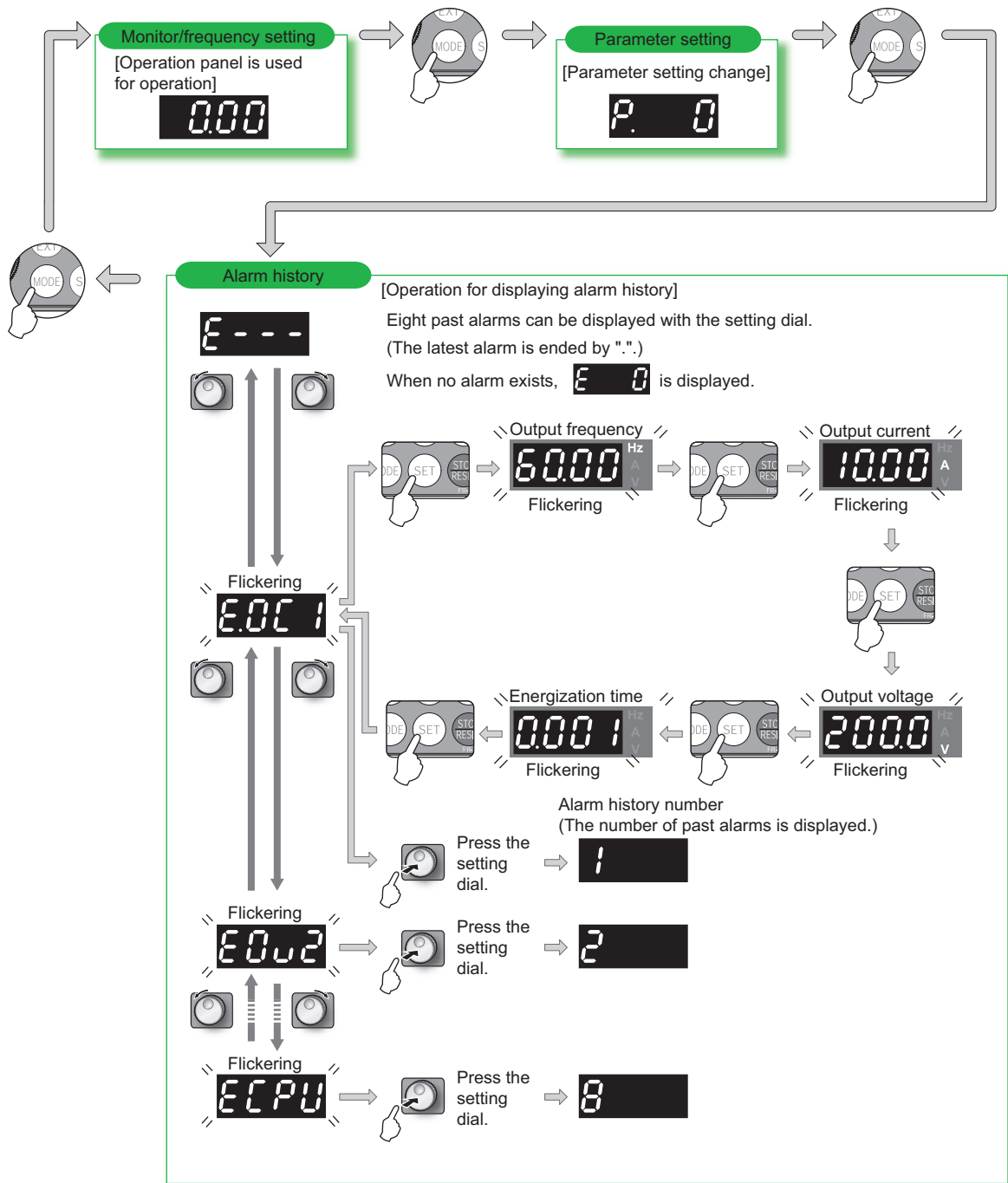

(2) Clearing procedure

POINT

- The alarm history can be cleared by setting "1" in *Er.CL Alarm history clear*. (The alarm history is not cleared when "1" is set in *Pr. 77 Parameter write selection*)

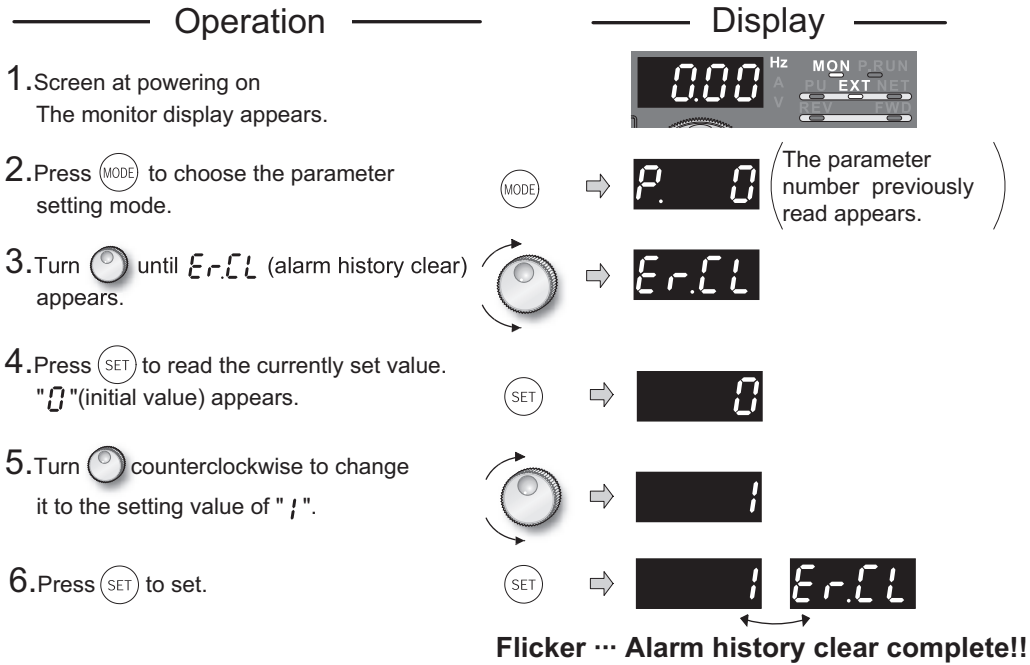

- Press to read another parameter.
- Press **(SET)** to show the setting again.
- Press **(SET)** twice to show the next parameter.



5.6 Check first when you have troubles.

POINT

If the cause is still unknown after every check, it is recommended to initialize the parameters (initial value) then re-set the required parameter values and check again.

5.6.1 Motor does not rotate as commanded

1) Check the *Pr. 0 Torque boost*. (Refer to page 53)

2) Check the main circuit.

- Check that a proper power supply voltage is applied (operation panel display is provided).
- Check that the motor is connected properly.
- Check that the jumper across P/+ - P1 is connected.

3) Check the input signals

- Check that the start signal is input.
- Check that both the forward and reverse rotation start signals are not input simultaneously.
- Check that the frequency setting signal is not zero. (When the frequency command is 0Hz and the run command is entered, FWD or REV LED on the operation panel flickers.)
- Check that the AU signal is on when the frequency setting signal is 4 to 20mA.
- Check that the output stop signal (MRS) or reset signal (RES) is not on.
- Check that the CS signal is not OFF with automatic restart after instantaneous power failure function is selected (*Pr. 57* ≠ "9999").
- Check that the sink or source jumper connector is fitted securely.

4) Check the parameter settings

- Check that the reverse rotation prevention selection (*Pr. 78*) is not selected.
- Check that the operation mode selection (*Pr. 79*) setting is correct.
- Check that the bias and gain (*calibration parameter C2 to C7*) settings are correct.
- Check that the starting frequency (*Pr. 13*) setting is not greater than the running frequency.
- Check that frequency settings of each running frequency (such as multi-speed operation) are not zero.
- Check that especially the maximum frequency (*Pr. 1*) is not zero.
- Check that the *Pr. 15 Jog frequency* setting is not lower than the *Pr. 13 Starting frequency* value.

5) Inspection of load

- Check that the load is not too heavy.
- Check that the shaft is not locked.

5.6.2 Motor generates abnormal noise

- No carrier frequency noises (metallic noises) are generated.
 - Soft-PWM operation to change the motor tone into an unoffending complex tone is factory-set to valid by the *Pr. 72 PWM frequency selection*.
Adjust *Pr. 72 PWM frequency selection* to change the motor tone.
(When operating the inverter with the carrier frequency of 3kHz or more set in *Pr. 72*, the carrier frequency will automatically decrease if the output current of the inverter exceeds the value in parenthesis of the rated output current on page 92. This may cause the motor noise to increase. But it is not a fault.)
- Check for any mechanical looseness.
- Contact the motor manufacturer.

5.6.3 Motor generates heat abnormally

- Is the fan for the motor is running? (Check for accumulated dust.)
- Check that the load is not too heavy. Lighten the load.
- Check that the inverter output voltages (U, V, W) balanced.
- Check that the *Pr. 0 Torque boost* setting is correct.



5.6.4 Motor rotates in opposite direction

- Check that the phase sequence of output terminals U, V and W is correct.
- Check that the start signals (forward rotation, reverse rotation) are connected properly. (Refer to page 43)

5.6.5 Speed greatly differs from the setting

- Check that the frequency setting signal is correct. (Measure the input signal level.)
- Check that Pr.1, Pr.2, Calibration parameter C2 to C7 settings are correct
- Check that the input signal lines are not affected by external noise. (Use shielded cables)
- Check that the load is not too heavy.
- Check that the Pr. 31 to Pr. 36 (frequency jump) settings are correct.

5.6.6 Acceleration/deceleration is not smooth

- Check that the acceleration and deceleration time settings are not too short.
- Check that the load is not too heavy.

5.6.7 Motor current is large

- Check that the load is not too heavy.
- Check that the Pr.0 Torque boost setting is correct.
- Check that the Pr.3 Base frequency setting is correct.
- Check that the Pr.19 Base frequency voltage is correct

5.6.8 Speed does not increase

- Check that the maximum frequency (Pr. 1) setting is correct. (If you want to run the motor at 120Hz or more, set Pr.18 High speed maximum frequency. (Refer to the Instruction Manual (applied).)
- Check that the load is not too heavy. (In agitators, etc., load may become heavier in winter.)
- Check that the brake resistor is not connected to terminals P/+-P1 accidentally.

5.6.9 Speed varies during operation

- 1) Inspection of load
 - Check that the load is not varying.
- 2) Check the input signals
 - Check that the frequency setting signal is not varying.
 - Check that the frequency setting signal is not affected by noise.
 - Check for a malfunction due to undesirable currents when the transistor output unit is connected. (Refer to page 23)
- 3) Others
 - Check that the wiring length is not too long for V/F control

5.6.10 Operation panel (FR-DU07) display is not operating

- Check that the operation panel is connected to the inverter securely.

5.6.11 Parameter write cannot be performed

- Make sure that operation is not being performed (signal STF or STR is not ON).
- Make sure that you are not attempting to set the parameter in the external operation mode.
- Check Pr.77 Parameter write selection.
- Check Pr.161 Frequency setting/key lock operation selection.

6 PRECAUTIONS FOR MAINTENANCE AND INSPECTION

The inverter is a static unit mainly consisting of semiconductor devices. Daily inspection must be performed to prevent any fault from occurring due to the adverse effects of the operating environment, such as temperature, humidity, dust, dirt and vibration, changes in the parts with time, service life, and other factors.

• Precautions for maintenance and inspection

For some short time after the power is switched off, a high voltage remains in the smoothing capacitor. When accessing the inverter for inspection, wait for at least 10 minutes after the power supply has been switched off, and then make sure that the voltage across the main circuit terminals P/+-N/- of the inverter is not more than 30VDC using a tester, etc.

6.1 Inspection Item

6.1.1 Daily inspection

Basically, check for the following faults during operation.

- (1) Motor operation fault
- (2) Improper installation environment
- (3) Cooling system fault
- (4) Unusual vibration and noise.
- (5) Unusual overheat and discoloration.

During operation, check the inverter input voltages using a tester.

6.1.2 Periodic inspection

Check the areas inaccessible during operation and requiring periodic inspection.

Consult us for periodic inspection.

- 1) Check for cooling system fault.....Clean the air filter, etc.
- 2) Tightening check and retighteningThe screws and bolts may become loose due to vibration, temperature changes, etc.
Tighten them according to the specified tightening torque. (*Refer to page 14.*)
- 3) Check the conductors and insulating materials for corrosion and damage.
- 4) Measure insulation resistance.
- 5) Check and change the cooling fan and relay.

6.1.3 Daily and periodic inspection

Area of Inspection	Inspection Item	Inspection Item	Interval			Method	Criterion	Instrument	Customer's check
			Daily	Periodic*					
				1 years	2 years				
General	Surrounding environment	Check ambient temperature, humidity, dust, dirt, etc.	○			Measure 5cm (1.97 inches) away from the inverter. <i>(Refer to page 7.)</i>	Ambient temperature: -10°C to +50°C (14°F to 122°F), non-freezing. Ambient humidity: 90% or less, non-condensing.	Thermometer, hygrometer, recorder	
	Overall unit	Check for unusual vibration and noise.	○			Visual and auditory checks.	No fault		
	Power supply voltage	Check that the main circuit voltages are normal.	○			Measure voltages across inverter terminal block R/L1, S/L2, T/L3 phases.	Within permissible AC (DC) voltage fluctuation <i>(Refer to page 92.)</i>	Tester, digital multimeter	
Main circuit	General	(1) Check with megger (across main circuit terminals and earth (ground) terminal) (2) Check for loose screws and bolts. (3) Check for overheat traces on the parts. (4) Clean.		○		(1) Disconnect all cables from the inverter and measure across terminals R/L1, S/L2, T/L3, U, V, W and earth terminal with megger. <i>(Refer to page 90.)</i> (2) Retighten. (3) Visual check	(1) 5MΩ or more. (2)(3) No fault	500VDC class megger	
	Conductors, cables	(1) Check conductors for distortion. (2) Check cable sheaths for breakage	○			(1)(2) Visual check	(1)(2) No fault		
	Terminal block	Check for damage.	○			Visual check	No fault		
	Inverter module, Converter module	Check resistance across terminals.		○		Disconnect all cables from the inverter and measure across terminals R/L1, S/L2, T/L3, P/+, N/- and U, V, W, P/+, N/- with a meter range of 100Ω.	(Refer to page 84)	Analog tester	
	Relay	(1) Check for chatter during operation. (2) Check for rough surface on contacts.	○			(1) Auditory check. (2) Visual check (3) Judge by the inrush current limit circuit and the life check of the relay.	(1)(2) No fault		
	Smoothing capacitors	Check for fluid leakage and crack.	○			Visual check and judge by the life check of the main circuit capacitor.			
				○					



Area of Inspection	Inspection Item	Inspection Item	Interval			Method	Criterion	Instrument	Customer's check
			Daily	Periodic*					
				1 years	2 years				
Control circuit Protective circuit	Operation check	(1) Check balance of output voltages across phases with the inverter operated alone. (2) Perform sequence protective operation test to ensure no fault in protective and display circuits.		○		(1) Measure voltages across the inverter output terminals U-V-W. (2) Simulatively short or open the protective circuit output terminals of the inverter.	(1) Phase to phase voltage balance is within 4V for the 200V and within 8V for the 400V (2) Fault must occur because of sequence.	Digital multimeter, rectifier type voltmeter	
	Smoothing capacitors	Check for fluid leakage and clack.		○		Visual check and judge by the life of the main circuit capacitor. (Refer to page 82.)			
Cooling system	Cooling fan	(1) Check for unusual vibration and noise. (2) Check for loose connection.	○		○	(1) Turn by hand with power off. (2) Visual check. (3) Judge by the life check of the cooling fan (Refer to page 82.)	No unusual vibration and noise.		
Display	Display	(1) Check for LED lamp blown. (2) Clean.	○		○	(1) Lamps indicate indicator lamps on panel. (2) Clean with rag	(1) Check that lamps are lit.		
	Meter	Check that reading is normal.	○			Check the readings of the meters on the panel.	Must satisfy specified and management values.	Voltmeter, ammeter, etc.	
Motor	General	(1) Check for unusual vibration and noise. (2) Check for unusual odor.	○		○	(1) Auditory, sensory, visual checks. (2) Check for unusual odor due to overheat, damage, etc.	(1)(2) No fault		
	Insulation resistance	Check with megger (across terminals and ground terminal).			○	Disconnect cables from U, V, W (including motor cables)	5MΩ or more.	500V megger	

*Consult us for periodic inspection.

6.1.4 Display of the life of the inverter parts

The self-diagnostic alarm is output when the life span of the control circuit capacitor, cooling fan, each parts of the inrush current limit circuit is near to give an indication of replacement time .

For the life check of the main circuit capacitor, the alarm signal (Y90) will not be output if a measuring method of (2) is not performed. (Refer to page 83.)

The life alarm output can be used as a guideline for life judgement.

Parts	Judgement level
Main circuit capacitor	85% of the initial capacity
Control circuit capacitor	Estimated 10% life remaining
Inrush current limit circuit	Estimated 10% life remaining (Power on: 100,000 times left)
Cooling fan	Less than 40% of the predetermined speed

(1) Display of the life alarm

- *Pr. 255* Life alarm status display can be used to confirm that the control circuit capacitor, main circuit capacitor, cooling fan, and each parts of the inrush current limit circuit has reached the life alarm output level.

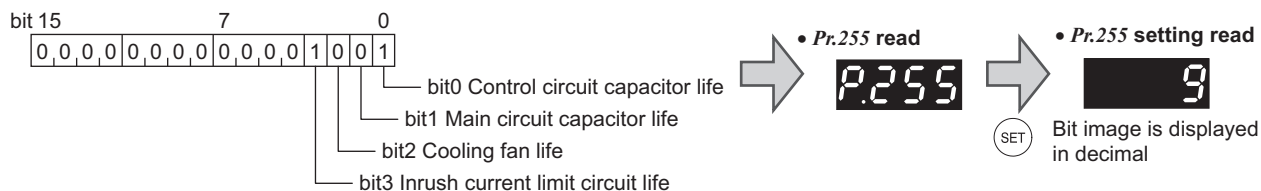

<i>Pr.255</i> (decimal)	bit (binary)	Inrush current limit circuit life	Cooling fan life	Main circuit capacitor life	Control circuit capacitor life
15	1111	○	○	○	○
14	1110	○	○	○	×
13	1101	○	○	×	○
12	1100	○	○	×	×
11	1011	○	×	○	○
10	1010	○	×	○	×
9	1001	○	×	×	○
8	1000	○	×	×	×
7	0111	×	○	○	○
6	0110	×	○	○	×
5	0101	×	○	×	○
4	0100	×	○	×	×
3	0011	×	×	○	○
2	0010	×	×	○	×
1	0001	×	×	×	○
0	0000	×	×	×	×

○: with alarm, ×: without alarm

POINT

Life check of the main circuit capacitor needs to be done by *Pr. 259*. (Refer to the following.)

(2) Measuring method of life of the main circuit capacitor

- If the value of capacitor capacity measured before shipment is considered as 100%, *Pr. 255* bit1 is turned on when the measured value falls below 85%.
- Measure the capacitor capacity according to the following procedure and check the deterioration level of the capacitor capacity.
 - 1) Check that the motor is connected and at a stop.
 - 2) Set "1" (measuring start) in *Pr. 259*
 - 3) Switch power off. The inverter applies DC voltage to the motor to measure the capacitor capacity while the inverter is off.
 - 4) After confirming that the LED of the operation panel is off, power on again.
 - 5) Check that "3" (measuring completion) is set in *Pr. 259*, then read *Pr. 255* and check the life of the main circuit capacitor.

REMARKS

- The life of the main circuit capacitor can not be measured in the following conditions.
 - (a) FR-HC, FR-CV, FR-BU, MT-HC, MT-RC, MT-BU5, or BU is connected.
 - (b) Terminal R1/L11, S1/L21 or DC power supply is connected to the terminals P/+ and N/-.
 - (c) Switch power on during measuring.
 - (d) The motor is not connected to the inverter.
 - (e) The motor is running.(The motor is coasting.)
 - (f) The motor capacity is two rank smaller as compared to the inverter capacity.
 - (g) The inverter is at an alarm stop or an alarm occurred while power is off.
 - (h) The inverter output is shut off with the MRS signal.
 - (i) The start command is given while measuring.
- Operating environment: Ambient temperature (annual average 40°C (104°F) (free from corrosive gas, flammable gas, oil mist, dust and dirt))
Output current (80% of the rated current of Mitsubishi standard 4P motor)

POINT

For the accurate life measuring of the main circuit capacitor, perform after more than 3h passed since the turn off of the power as it is affected by the capacitor temperature.



6.1.5 Checking the inverter and converter modules

<Preparation>

- (1) Disconnect the external power supply cables (R/L1, S/L2, T/L3) and motor cables (U, V, W).
- (2) Prepare a tester. (Use 100Ω range.)

<Checking method>

Change the polarity of the tester alternately at the inverter terminals R/L1, S/L2, T/L3, U, V, W, P/+ and N/–, and check for continuity.

CAUTION

1. Before measurement, check that the smoothing capacitor is discharged.
2. At the time of discontinuity, due to the smoothing capacitor, the tester may not indicate ∞. At the time of continuity, the measured value is several ten's-of ohms depending on the module type, circuit tester type, etc. If all measured values are almost the same, the modules are without fault.

<Module device numbers and terminals to be checked>

	Tester Polarity		Measured Value		Tester Polarity		Measured Value	
	⊕	⊖			⊕	⊖		
Converter module	D1	R/L1	P/+	Discontinuity	D4	R/L1	N/–	Continuity
		P/+	R/L1	Continuity		N/–	R/L1	Discontinuity
	D2	S/L2	P/+	Discontinuity	D5	S/L2	N/–	Continuity
		P/+	S/L2	Continuity		N/–	S/L2	Discontinuity
	D3	T/L3	P/+	Discontinuity	D6	T/L3	N/–	Continuity
		P/+	T/L3	Continuity		N/–	T/L3	Discontinuity
Inverter module	TR1	U	P/+	Discontinuity	TR4	U	N/–	Continuity
		P/+	U	Continuity		N/–	U	Discontinuity
	TR3	V	P/+	Discontinuity	TR6	V	N/–	Continuity
		P/+	V	Continuity		N/–	V	Discontinuity
	TR5	W	P/+	Discontinuity	TR2	W	N/–	Continuity
		P/+	W	Continuity		N/–	W	Discontinuity

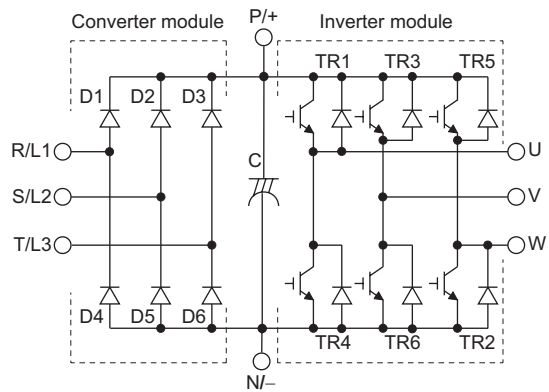

(Assumes the use of an analog meter.)

6.1.6 Cleaning

Always run the inverter in a clean status.

When cleaning the inverter, gently wipe dirty areas with a soft cloth immersed in neutral detergent or ethanol.

CAUTION

Do not use solvent, such as acetone, benzene, toluene and alcohol, as they will cause the inverter surface paint to peel off.

6.1.7 Replacement of parts

The inverter consists of many electronic parts such as semiconductor devices.

The following parts may deteriorate with age because of their structures or physical characteristics, leading to reduced performance or fault of the inverter. For preventive maintenance, the parts must be replaced periodically. Use the life check function as a guidance of parts replacement.

Part Name	Standard Replacement Interval*	Description
Cooling fan	10 years	Replace (as required.)
Main circuit smoothing capacitor	10 years	Replace (as required.)
On-board smoothing capacitor	10 years	Replace the board (as required)
Relays	-	as required.
Fuse (FR-F740-04320 or more)	10 years	Replace the fuse (as required)

* Replacement years for when the yearly average ambient temperature is 40°C (104°F)
(without corrosive gas, flammable gas, oil mist, dust and dirt etc)

CAUTION

For parts replacement, consult the nearest Mitsubishi FA Center.

(1) Cooling fan

The replacement interval of the cooling fan used for cooling the parts generating heat such as the main circuit semiconductor is greatly affected by the ambient temperature. When unusual noise and/or vibration is noticed during inspection, the cooling fan must be replaced immediately.

Inverter Type	Fan Type	Units	
200V class	00105 to 00250	MMF-06F24ES-RP1 BKO-CA1638H01 1	
	00340 to 00630	MMF-08D24ES-RP1 BKO-CA1639H01 2	
	00770, 00930	MMF-12D24DS-RP1 BKO-CA1619H01 1	
	01250	MMF-06F24ES-RP1 BKO-CA1638H01 1	
		MMF-12D24DS-RP1 BKO-CA1619H01 1	
	01540	MMF-09D24TS-RP1 BKO-CA1640H01 2	
	01870, 02330	MMF-12D24DS-RP1 BKO-CA1619H01 2	
03160 to 04750	MMF-12D24DS-RP1 BKO-CA1619H01 3		
400V class	00083, 00126	MMF-06F24ES-RP1 BKO-CA1638H01 1	
	00170 to 00380	MMF-08D24ES-RP1 BKO-CA1639H01 2	
	00470, 00620	MMF-12D24DS-RP1 BKO-CA1619H01 1	
	00770	MMF-09D24TS-RP1 BKO-CA1640H01 2	
	00930 to 01800	MMF-12D24DS-RP1 BKO-CA1619H01	
	02160 to 03610		3
	04320, 04810	9LB1424H5H03	3
	05470 to 06830		4
	07700, 08660		5
09620 to 12120	9LB1424S5H03 6		

The FR-F720-00046, 00077, FR-F740-00023 to 00052 are not provided with a cooling fan.



- Removal (FR-F720-00105 to 04750, FR-F740-00083 to 03610)

1) Push the hooks from above and remove the fan cover.

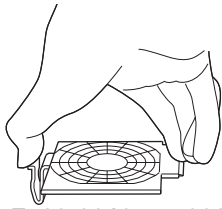

FR-F720-00105 to 00250
FR-F740-00083, 00126

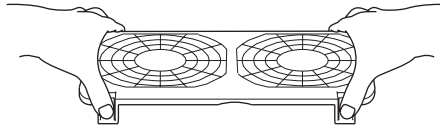

FR-F720-00340 to 01250
FR-F740-00170 to 00620

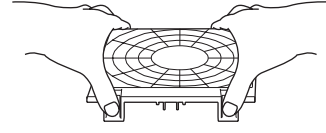

FR-F720-01540 to 04750
FR-F740-00770 to 03610

2) Disconnect the fan connectors.

3) Remove the fan.

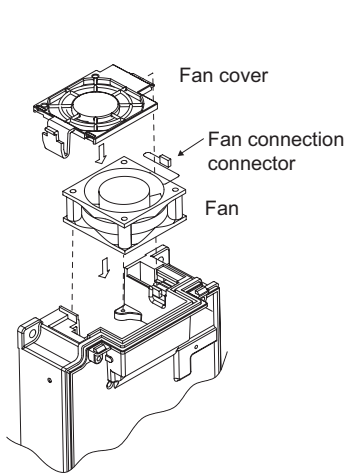

FR-F720-00105 to 00250
FR-F740-00083, 00126

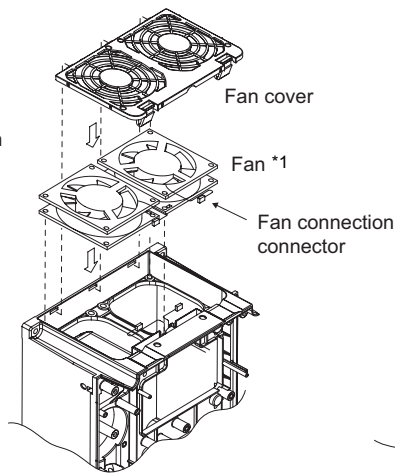

FR-F720-00340 to 01250
FR-F740-00170 to 00620

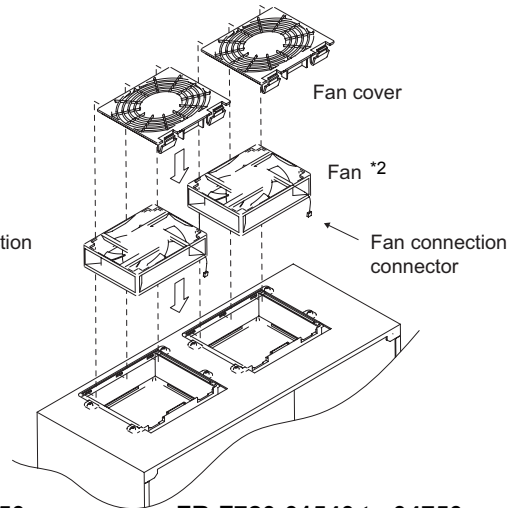

FR-F720-01540 to 04750
FR-F740-00770 to 03610

* The number of cooling fans differs according to the inverter capacity. (Refer to page 85)

• Reinstallation (FR-F720-00105 to 04750, FR-F740-00083 to 03610)

- 1) After confirming the orientation of the fan, reinstall the fan so that the arrow on the left of "AIR FLOW" faces up.

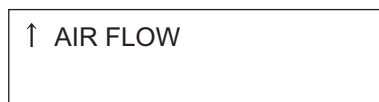

<Fan side face>

CAUTION

Installing the fan in the opposite air flow direction can cause the inverter life to be shorter.

- 2) Reconnect the fan connectors.

When wiring, use care to avoid the cables being caught by the fan.

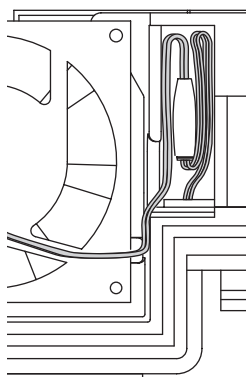

FR-F720-00105 to 00250
FR-F740-00083, 00126

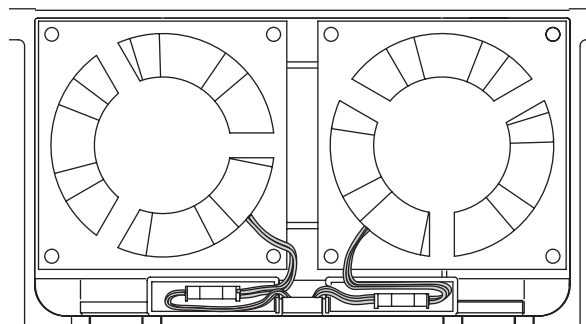

FR-F720-00340 to 00630
FR-F740-00170 to 00380

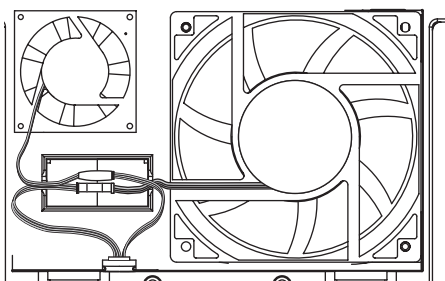

FR-F720-01250

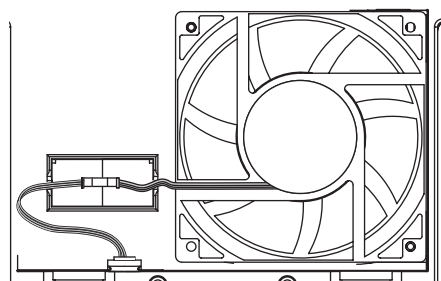

FR-F720-00770, 00930
FR-F740-00470, 00620

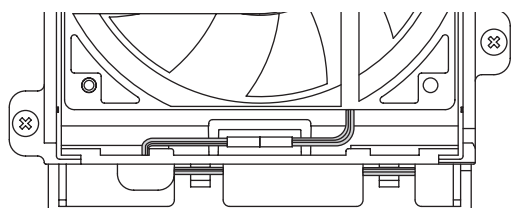

FR-F720-01540 to 04750
FR-F740-00770 to 03610

- 3) Reinstall the fan cover.

2. Insert hooks until you hear a click sound.

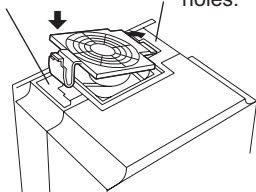

FR-F720-00105 to 00250
FR-F740-00083, 00126

1. Insert hooks into holes.

1. Insert hooks into holes.

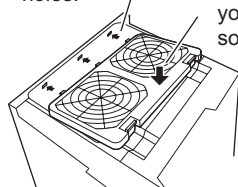

FR-F720-00340 to 01250
FR-F740-00170 to 00620

2. Insert hooks until you hear a click sound.

1. Insert hooks into holes.

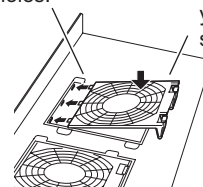

FR-F720-01540 to 04750
FR-F740-00770 to 03610

2. Insert hooks until you hear a click sound.



- Removal (FR-F740-04320 or more)

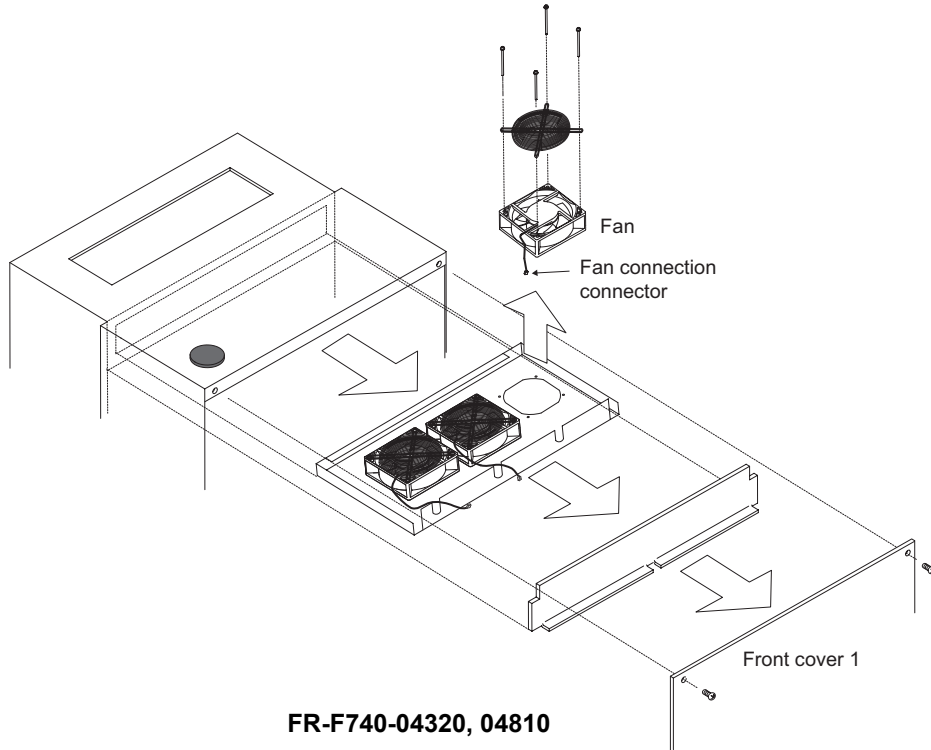

FR-F740-04320, 04810

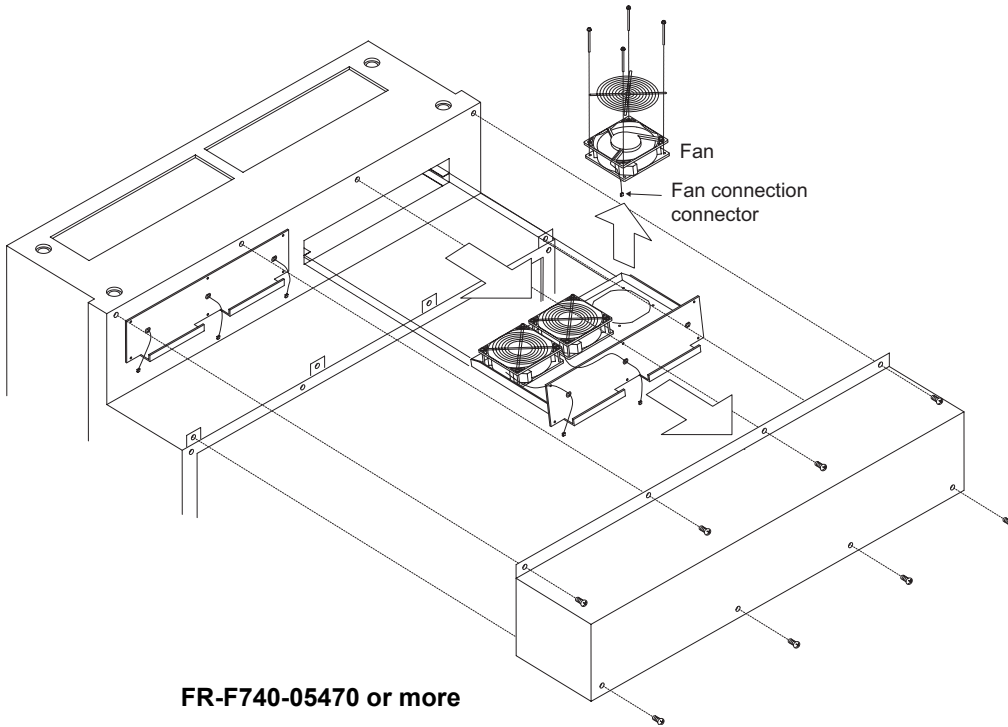

FR-F740-05470 or more

* The number of cooling fans differs according to the inverter capacity. (Refer to page 85)

- Reinstallation (FR-F740-04320 or more)

1) After confirming the orientation of the fan, reinstall the fan so that the arrow on the left of "AIR FLOW" faces up.



<Fan side face>

CAUTION

Installing the fan in the opposite air flow direction can cause the inverter life to be shorter.

2) Install fans referring to the above figure.

(2) Smoothing capacitors

A large-capacity aluminum electrolytic capacitor is used for smoothing in the main circuit DC section, and an aluminum electrolytic capacitor is used for stabilizing the control power in the control circuit. Their characteristics are deteriorated by the adverse effects of ripple currents, etc.

The replacement intervals greatly vary with the ambient temperature and operating conditions. When the inverter is operated in air-conditioned, normal environment conditions, replace the capacitors about every 10 years.

The appearance criteria for inspection are as follows:

- 1) Case: Check the side and bottom faces for expansion
- 2) Sealing plate: Check for remarkable warp and extreme crack.
- 3) Check for external crack, discoloration, fluid leakage, etc. Judge that the capacitor has reached its life when the measured capacitance of the capacitor reduced below 80% of the rating.

(3) Relays

To prevent a contact fault, etc., relays must be replaced according to the cumulative number of switching times (switching life).

6.1.8 Inverter replacement

The inverter can be replaced with the control circuit wiring kept connected. Before replacement, remove the wiring cover of the inverter.

- 1) Loosen the two installation screws in both ends of the control circuit terminal block. (These screws cannot be removed.)
Pull down the terminal block from behind the control circuit terminals.

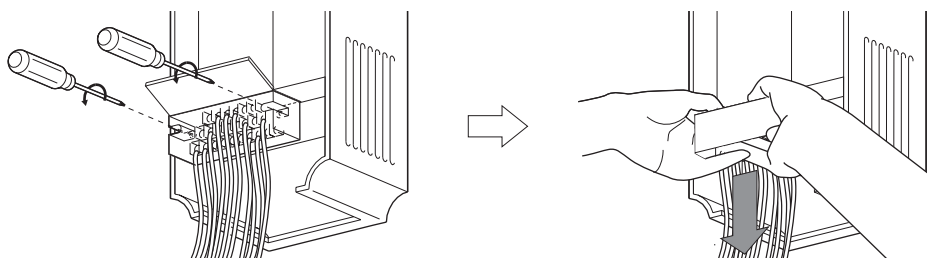

- 2) Using care not to bend the pins of the inverter's control circuit connector, reinstall the control circuit terminal block and fix it with the mounting screws.

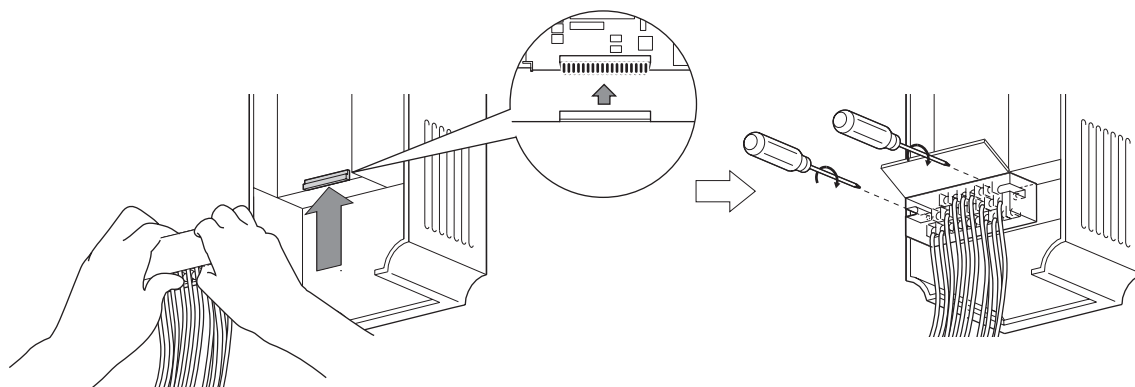

CAUTION

Before starting inverter replacement, switch power off, wait for at least 10 minutes, and then check the voltage with a tester and such to ensure safety.



6.2 Measurement of main circuit voltages, currents and powers

6.2.1 Insulation resistance test using megger

For the inverter, conduct the insulation resistance test on the main circuit only as shown below and do not perform the test on the control circuit. (Use a 500VDC megger.)

CAUTION

- Before performing the insulation resistance test on the external circuit, disconnect the cables from all terminals of the inverter so that the test voltage is not applied to the inverter.
- For the continuity test of the control circuit, use a tester (high resistance range) and do not use the megger or buzzer.

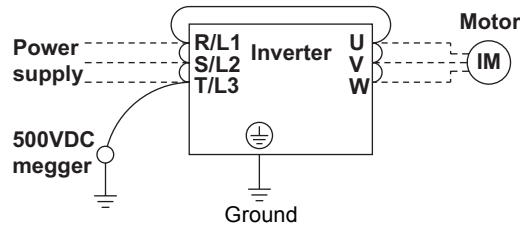

6.2.2 Pressure test

Do not conduct a pressure test. Deterioration may occur.

6.2.3 Measurement of voltages and currents

Since the voltages and currents on the inverter power supply and output sides include harmonics, measurement data depends on the instruments used and circuits measured.

When instruments for commercial frequency are used for measurement, measure the following circuits with the instruments given on the next page.

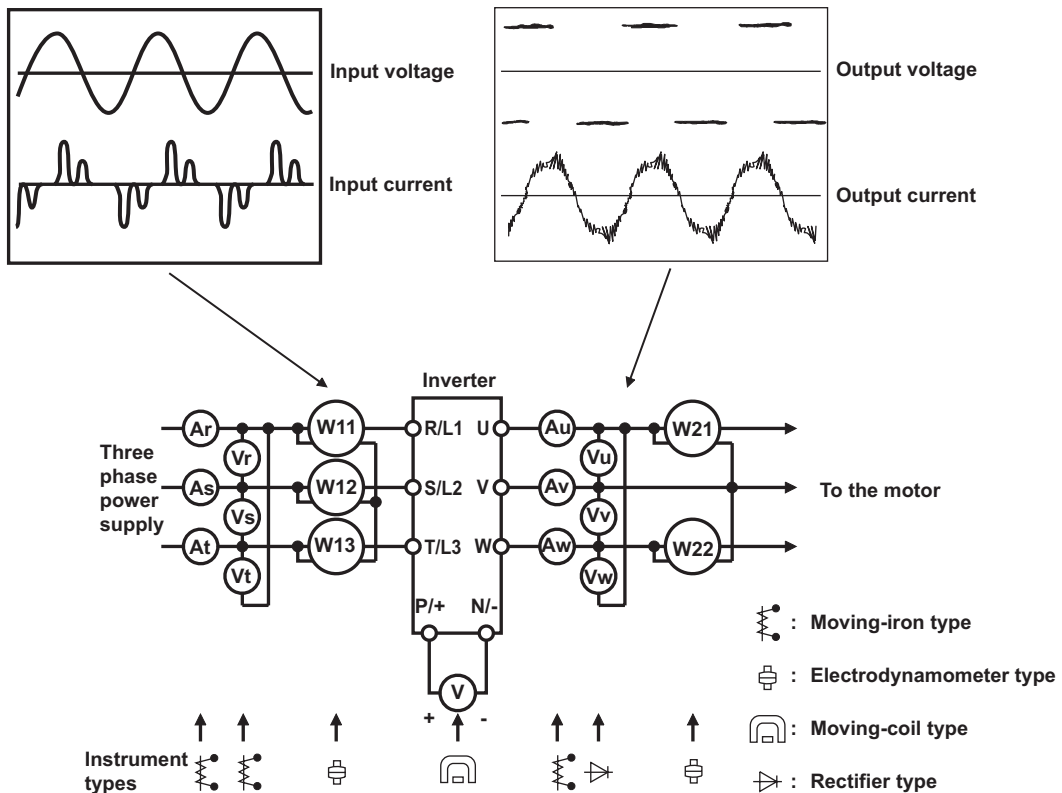

Examples of Measuring Points and Instruments

7 SPECIFICATIONS

7.1 Rating

•200V class

SLD is initially set.

Type FR-F720-□□□□□□-NA	00046	00077	00105	00167	00250	00340	00490	00630	00770	00930	01250	01540	01870	02330	03160	03800	04750	
Applied motor capacity (kW(HP)) ^{*1}	LD	0.75	1.5	2.2	3.7	5.5	7.5	11	15	18.5	22	30	37	45	55	75	90	110
	SLD	(1)	(2)	(3)	(5)	(7.5)	(10)	(15)	(20)	(25)	(30)	(40)	(50)	(60)	(75)	(100)	(125)	(150)
Rated capacity (kVA) ^{*2}	LD	1.6	2.7	3.7	5.8	8.8	11.8	17.1	22.1	27	32	43	53	65	81	110	132	165
	SLD																	
Rated current (A) ^{*3}	LD	4.2	7	9.6	15.2	23	31	45	58	70	85	114	140	170	212	288	346	432
	SLD	(3.6)	(6.0)	(8.2)	(12.9)	(20)	(26)	(38)	(49)	(60)	(72)	(97)	(119)	(145)	(180)	(244)	(294)	(367)
Overload current rating ^{*4}	LD	120% 60s, 150% 3s, 50°C (122°F) (inverse time characteristics)																
	SLD	110% 60s, 120% 3s, 40°C (104°F) (inverse time characteristics)																
Voltage ^{*5}	Three-phase 200 to 240V																	
Power supply	Rated input AC voltage/frequency	Three-phase 200 to 220V 50Hz, 200 to 240V 60Hz																
	Permissible AC voltage fluctuation	170 to 242V 50Hz, 170 to 264V 60Hz																
	Permissible frequency fluctuation	±5%																
	Power supply system capacity (kVA) ^{*6}	2.5	4.5	5.5	9	12	17	20	28	34	41	52	65	79	99	110	132	165
Protective structure (JEM 1030(NEMA250-1997)) ^{*8}	Enclosed type (IP20 NEMA1) ^{*7}										Open type (IP00)							
	Cooling system	Self-cooling		Forced air cooling														
Approx. mass (kg (lbs))	1.9	2.3	3.6	3.6	3.6	6.6	6.6	7.6	13	13	14	23	35	35	67	70	70	
	(4.1)	(5.0)	(7.9)	(7.9)	(7.9)	(14.5)	(14.5)	(16.7)	(28.6)	(28.6)	(30.8)	(50.6)	(77)	(77)	(147.4)	(154)	(154)	

*1 The applied motor capacity indicated is the maximum capacity applicable for use of the Mitsubishi 4-pole standard motor.

*2 The rated output capacity indicated assumes that the output voltage is 220V.

*3 When operating the inverter with the carrier frequency set to 3kHz or more, the carrier frequency automatically decreases if the inverter output current exceeds the value in parenthesis of the rated current. This may cause the motor noise to increase.

*4 The % value of the overload current rating indicated is the ratio of the overload current to the inverter's rated output current. For repeated duty, allow time for the inverter and motor to return to or below the temperatures under 100% load.

*5 The maximum output voltage does not exceed the power supply voltage. The maximum output voltage can be changed within the setting range. However, the pulse voltage value of the inverter output side voltage remains unchanged at about $\sqrt{2}$ that of the power supply.

*6 The power supply capacity varies with the value of the power supply side inverter impedance (including those of the input reactor and cables).

*7 When the hook of the inverter front cover is cut off for installation of the plug-in option, the inverter changes to an open type (the structure is no longer NEMA1).

*8 FR-DU07: IP40 (except for the PU connector)



•400V class

SLD is initially set.

Type FR-F740-□□□□□-NA		00023	00038	00052	00083	00126	00170	00250	00310	00380	00470	00620	00770	00930	01160	
Applied motor capacity (kW(HP)) ^{*1}	LD	0.75	1.5	2.2	3.7	5.5	7.5	11	15	18.5	22	30	37	45	55	
	SLD	(1)	(2)	(3)	(5)	(7.5)	(10)	(15)	(20)	(25)	(30)	(40)	(50)	(60)	(75)	
Rated capacity (kVA) ^{*2}	LD	1.6	2.7	3.7	5.8	8.8	12.2	17.5	22.1	26.7	32.8	43.4	53.3	64.8	80.8	
	SLD															
Rated current (A) ^{*3}	LD	2.1	3.5	4.8	7.6	11.5	16	23	29	35	43	57	70	85	106	
	SLD	(1.8)	(3.0)	(4.1)	(6.5)	(9.8)	(13.6)	(20)	(25)	(30)	(37)	(48)	(60)	(72)	(90)	
Overload current rating ^{*4}	LD	120% 60s, 150% 3s, 50°C (122°F) (inverse time characteristics)														
	SLD	110% 60s, 120% 3s, 40°C (104°F) (inverse time characteristics)														
Voltage ^{*5}		Three-phase 380 to 480V														
Power supply	Rated input AC voltage/frequency	Three-phase 380 to 480V 50Hz/60Hz														
	Permissible AC voltage fluctuation	323 to 528V 50Hz/60Hz														
	Permissible frequency fluctuation	±5%														
	Power supply system capacity (kVA) ^{*6}	2.5	4.5	5.5	9	12	17	20	28	34	41	52	66	80	100	
Protective structure (JEM 1030(NEMA250-1997)) ^{*8}		Enclosed type (IP20 NEMA1) ^{*7}											Open type (IP00)			
Cooling system		Self-cooling					Forced air cooling									
Approx. mass (kg (lbs))		3.6	3.6	3.6	3.6	3.6	6.6	6.6	7.6	7.6	13	13	23	35	35	
		(7.9)	(7.9)	(7.9)	(7.9)	(7.9)	(14.5)	(14.5)	(16.7)	(16.7)	(28.7)	(28.7)	(50.7)	(77.2)	(77.2)	

Type FR-F740-□□□□□-NA		01800	02160	02600	03250	03610	04320	04810	05470	06100	06830	07700	08660	09620	10940	12120
Applied motor capacity (kW(HP)) ^{*1}	LD	75	90	110	132	160	185	220	250	280	315	355	400	450	500	560
	SLD	(100)	(150)	(150)	(200)	(250)	(300)	(350)	(400)	(450)	(500)	(550)	(600)	(700)	(750)	(800)
Rated capacity (kVA) ^{*2}	LD	110	137	165	198	247	275	329	366	416	464	520	586	659	733	833
	SLD	(150)	(150)	(200)	(250)	(300)	(350)	(400)	(450)	(500)	(550)	(600)	(700)	(750)	(800)	(850)
Rated current (A) ^{*3}	LD	144	180	216	260	325	361	432	481	547	610	683	770	866	962	1094
	SLD	(122)	(153)	(184)	(221)	(276)	(306)	(367)	(408)	(464)	(518)	(580)	(654)	(736)	(817)	(929)
Overload current rating ^{*4}	LD	120% 60s, 150% 3s, 50°C (122°F) (inverse time characteristics)														
	SLD	110% 60s, 120% 3s, 40°C (104°F) (inverse time characteristics)														
Voltage ^{*5}		Three-phase 380 to 480V														
Power supply	Rated input AC voltage/frequency	Three-phase 380 to 480V 50Hz/60Hz														
	Permissible AC voltage fluctuation	323 to 528V 50Hz/60Hz														
	Permissible frequency fluctuation	±5%														
	Power supply system capacity (kVA) ^{*6}	LD	110	137	165	198	247	275	329	366	416	464	520	586	659	733
	SLD	137	165	198	247	275	329	366	416	464	520	586	659	733	833	923
Protective structure (JEM 1030(NEMA250-1997)) ^{*8}		Open type (IP00)														
Cooling system		Forced air cooling														
Approx. mass (kg (lbs))		37	50	57	72	72	110	110	220	220	220	260	260	370	370	370
		(81.6)	(110.2)	(125.4)	(158.4)	(158.4)	(242)	(242)	(484)	(484)	(484)	(572)	(572)	(814)	(814)	(814)

*1 The applied motor capacity indicated is the maximum capacity applicable for use of the Mitsubishi 4-pole standard motor.
 *2 The rated output capacity indicated assumes that the output voltage is 440V.
 *3 When operating the inverter with the carrier frequency set to 3kHz or more, the carrier frequency automatically decreases if the inverter output current exceeds the value in parenthesis of the rated current. This may cause the motor noise to increase.
 *4 The % value of the overload current rating indicated is the ratio of the overload current to the inverter's rated output current. For repeated duty, allow time for the inverter and motor to return to or below the temperatures under 100% load.
 *5 The maximum output voltage does not exceed the power supply voltage. The maximum output voltage can be changed within the setting range. However, the pulse voltage value of the inverter output side voltage remains unchanged at about $\sqrt{2}$ that of the power supply.
 *6 The power supply capacity varies with the value of the power supply side inverter impedance (including those of the input reactor and cables).
 *7 When the hook of the inverter front cover is cut off for installation of the plug-in option, the inverter changes to an open type (the structure is no longer NEMA1).
 *8 FR-DU07: IP40 (except for the PU connector)



7.2 Common specifications

Control specifications	Control system		High carrier frequency PWM control (V/F control)/optimum excitation control/simple magnetic flux vector control	
	Output frequency range		0.5 to 400Hz	
	Frequency setting resolution	Analog input	0.015Hz/0 to 60Hz (terminal 2, 4: 0 to 10V/12bit) 0.03Hz/0 to 60Hz (terminal 2, 4: 0 to 5V/11bit, 0 to 20mA/11bit, terminal 1: -10V to +10V/11bit) 0.06Hz/0 to 60Hz (terminal 1: 0 to ±5V/10bit)	
		Digital input	0.01Hz	
	Frequency accuracy	Analog input	Within ±0.2% of the max. output frequency (25°C ± 10°C (77°F ± 50°F))	
		Digital input	Within 0.01% of the set output frequency	
	Voltage/frequency characteristics		0 to 400Hz of the base frequency can be set from constant torque/adjustable 5 points V/F can be selected.	
	Starting torque		120% (3Hz) when simple magnetic flux vector control and slip compensation are set	
	Acceleration/deceleration time setting		0 to 3600s (acceleration and deceleration can be set individually), linear or S-pattern acceleration/deceleration mode can be selected.	
	DC injection brake		Operation frequency (0 to 120Hz), operation time (0 to 10s), operation voltage (0 to 30%) variable	
Stall prevention operation level		Operation current level can be set (0 to 150% variable), whether to use the function or not can be set.		
Operation specifications	Frequency setting signal	Analog input	Terminal 2, 4: 0 to 10V, 0 to 5V, 4 to 20mA can be selected Terminal 1: -10 to +10V, -5 to 5V can be selected	
		Digital input	Four-digit BCD or 16-bit binary using the setting dial of the operation panel or parameter unit (when used with the option FR-A7AX)	
	Start signal		Available individually for forward rotation and reverse rotation. Start signal automatic self-holding input (3-wire input) can be selected.	
	Input signals		You can select any twelve signals using <i>Pr.178 to Pr.189 (input terminal function selection)</i> from among multi speed selection, second function selection, terminal 4 input selection, JOG operation selection, selection of automatic restart after instantaneous power failure, external thermal relay input, HC connection (inverter operation enable signal), HC connection (instantaneous power failure detection), PU operation/external interlock signal, External DC injection brake operation start, PID control enable terminal, PU operation, external operation switchover, output stop, start self-holding selection, forward rotation command, reverse rotation command, inverter reset, PTC thermistor input, PID forward reverse operation switchover, PU-NET operation switchover, External-NET operation switchover, command source switchover.	
	Operational functions		Maximum and minimum frequency settings, frequency jump operation, external thermal relay input selection, polarity reversible operation, automatic restart after instantaneous power failure operation, original operation continuation at an instantaneous power failure, commercial power supply-inverter switchover operation, forward/reverse rotation prevention, operation mode selection, external DC injection braking start, PID control, computer link operation (RS-485).	
	Output signals	Operating status		You can select any seven signals using <i>Pr.190 to Pr.196 (output terminal function selection)</i> from among inverter running, up-to-speed, instantaneous power failure /undervoltage, overload warning, output frequency detection, second output frequency detection, regenerative brake prealarm ⁴ , electronic thermal relay function pre-alarm, PU operation mode, inverter operation ready, output current detection, zero current detection, PID lower limit, PID upper limit, PID forward rotation reverse rotation output, commercial power supply-inverter switchover MC1 to MC3, commercial power supply side moter 1 to 4 connection, inverter side moter 1 to 4 connection, fan fault output, heatsink overheat pre-alarm, inverter running start command on, deceleration at an instantaneous power failure, PID control activated, during retry, during PID output suspension, life alarm, alarm output 3 (power-off signal), power savings average value update timing, current average monitor, alarm output 2, maintenance timer alarm, remote output, minor failure output, alarm output. Open collector output (5 points), relay output (2 points) and alarm code of the inverter can be output (4 bit) from the open collector.
		When used with the FR-A7AY, FR-A7AR (option)		You can select any seven signals using <i>Pr.313 to Pr. 319 (extension output terminal function selection)</i> from among control circuit capacitor life, main circuit capacitor life, cooling fan life, inrush current limit circuit life. (Only positive logic can be set for extension terminals of the FR-A7AR)
		Pulse/analog output		Selection can be made from output frequency, motor current (steady or peak value), output voltage, frequency setting value, running speed, converter output voltage (steady or peak value), electronic thermal relay function load factor, input power, output power, load meter, reference voltage output, motor load factor, power saving effect, regenerative brake duty ⁴ , PID set value, PID measured value using <i>Pr.54 CA terminal function selection (pulse train output)</i> and <i>Pr.158 AM terminal function selection (analog output)</i> .

Display	PU (FR-DU07/ FR-PU04)	Operating status	Output frequency, motor current (steady or peak value), output voltage, alarm indication, frequency setting, running speed, converter output voltage (steady or peak value), electronic thermal relay function load factor, input power, output power, load meter, cumulative energization time, actual operation time, motor load factor, cumulative power, power saving effect, cumulative saving power, regenerative brake duty ^{*4} , PID set point, PID measured value, PID deviation value, inverter I/O terminal monitor, input terminal option monitor ^{*1} , output terminal option monitor ^{*1} , option fitting status monitor ^{*2} , terminal assignment status ^{*2}
		Alarm definition	Alarm definition is displayed during the protective function is activated, output voltage/current/frequency/cumulative energization time and eight past alarm definition is stored.
		Interactive guidance	Operation guide/trouble shooting with a help function ^{*2}
Protective/warning function			Overcurrent during acceleration, overcurrent during constant speed, overcurrent during deceleration, overvoltage during acceleration, overvoltage during constant speed, overvoltage during deceleration, inverter protection thermal operation, motor protection thermal operation, heatsink overheat, instantaneous power failure occurrence, undervoltage, input phase failure, motor overload, output side ground fault overcurrent, output phase failure, external thermal relay operation, PTC thermistor operation, option alarm, parameter error, PU disconnection, retry count excess, CPU alarm, operation panel power supply short circuit, 24VDC power output short circuit, output current detection value excess, inrush resistance overheat, communication alarm (inverter), analog input alarm, internal circuit error (15V power supply), fan fault, overcurrent stall prevention, overvoltage stall prevention, electronic thermal relay function prealarm, PU stop, maintenance timer alarm ^{*1} , brake transistor alarm detection ^{*4} , parameter write error, copy operation error, operation panel lock, parameter copy
Environment	Ambient temperature	LD	-10°C to +50°C(14°F to 122°F) (non-freezing)
		SLD (initial setting)	-10°C to +40°C(14°F to 104°F) (non-freezing)
	Ambient humidity	90%RH or less (non-condensing)	
	Storage temperature ^{*3}	-20°C to +65°C (-4°F to +149°F)	
	Atmosphere	Indoors (without corrosive gas, flammable gas, oil mist, dust and dirt etc.)	
	Altitude, vibration	Maximum 1000m (3280.80 feet) above sea level for standard operation. After that derate by 3% for every extra 500m (1640.40 feet) up to 2500m (8202.10 feet) (92%) 5.9m/s ² or less ^{*5} (conforming to JIS C 60068-2-6)	

*1 Can be displayed only on the operation panel (FR-DU07).

*2 Can be displayed only on the parameter unit (FR-PU04).

*3 Temperature applicable for a short period in transit, etc.

*4 Only the FR-F720-03160 (FR-F740-01800) or more functions.

*5 2.9m/s² or less for the FR-F740-04320 or more.



7.3 Outline dimension drawings

7.3.1 Inverter outline dimension drawings

- FR-F720-00046, 00077-NA

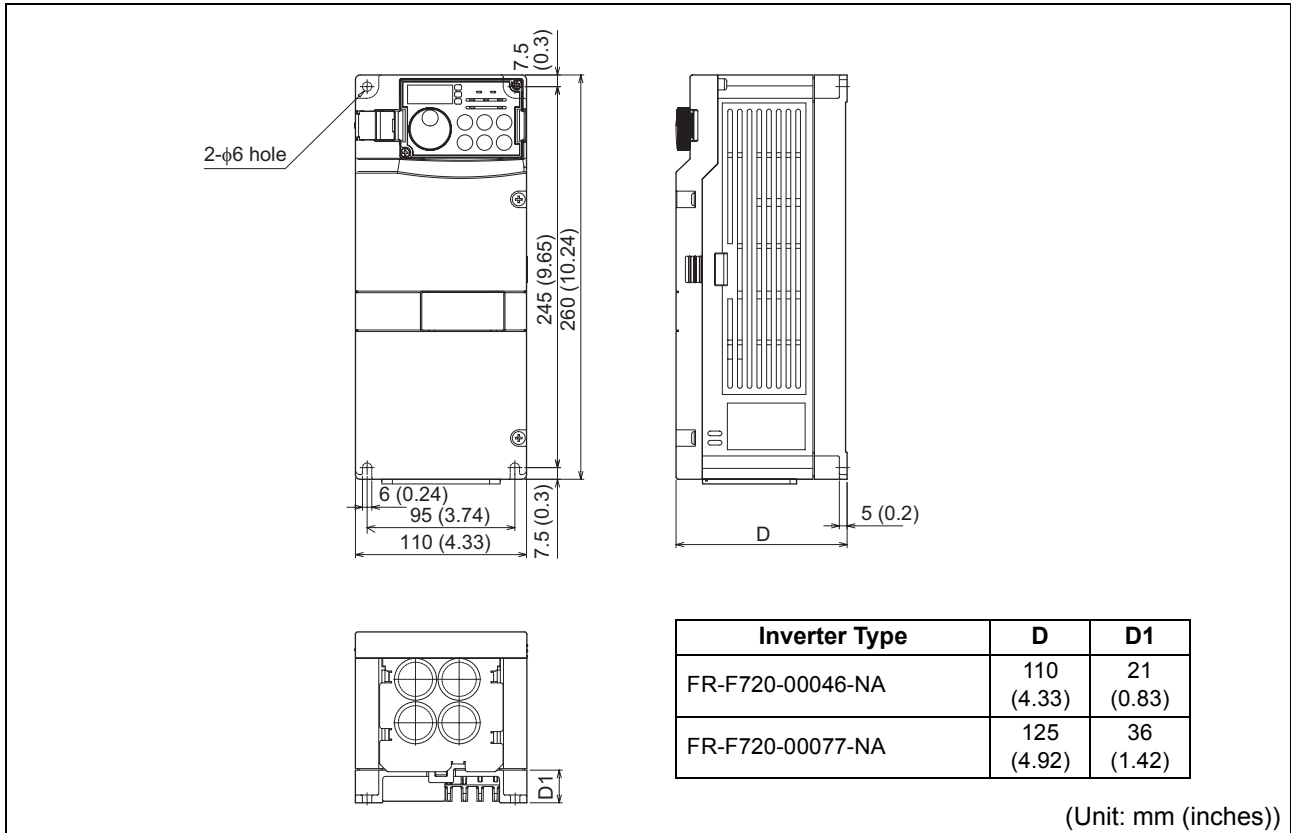

- FR-F720-00105, 00167, 00250-NA
- FR-F740-00023, 00038, 00052, 00083, 00126-NA

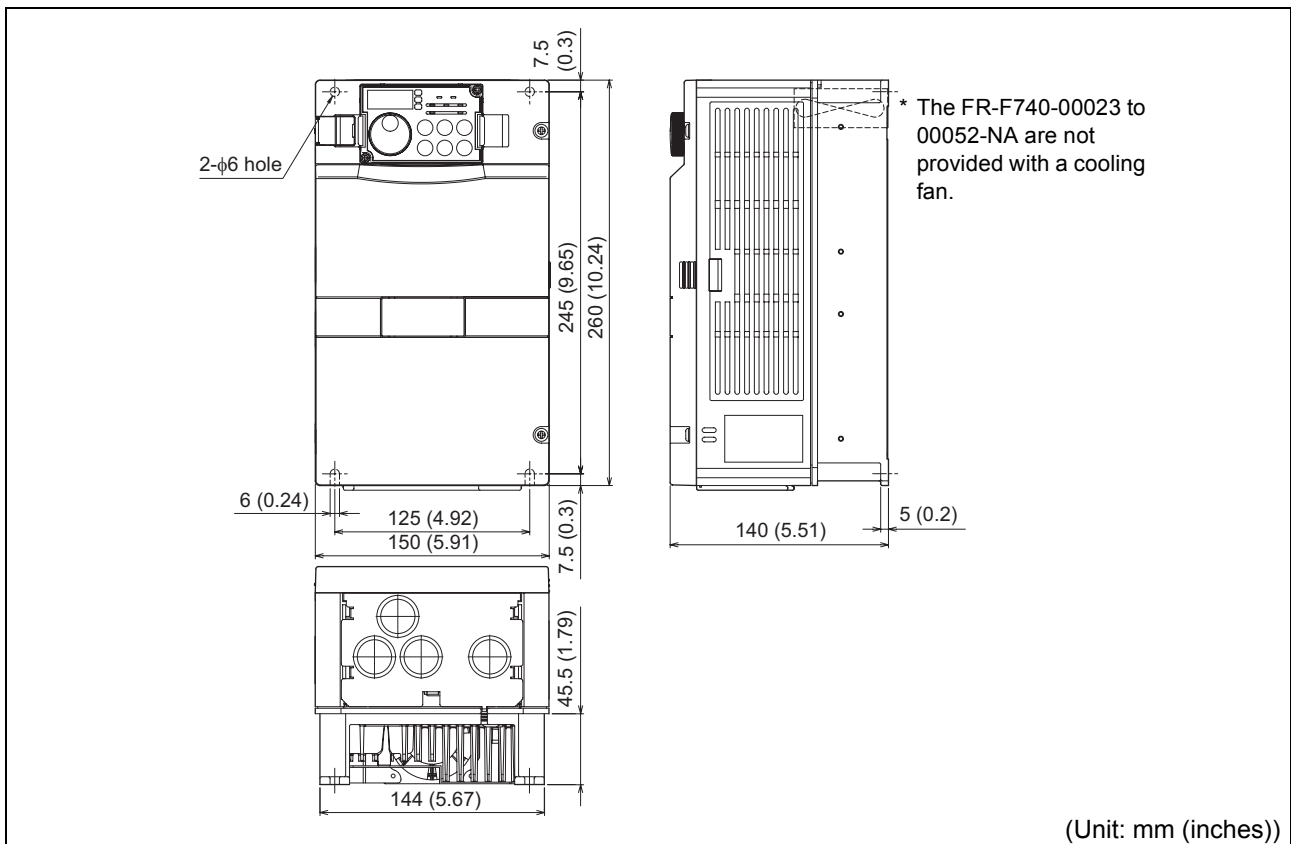

- FR-F720-00340, 00490, 00630-NA
- FR-F740-00170, 00250, 00310, 00380-NA

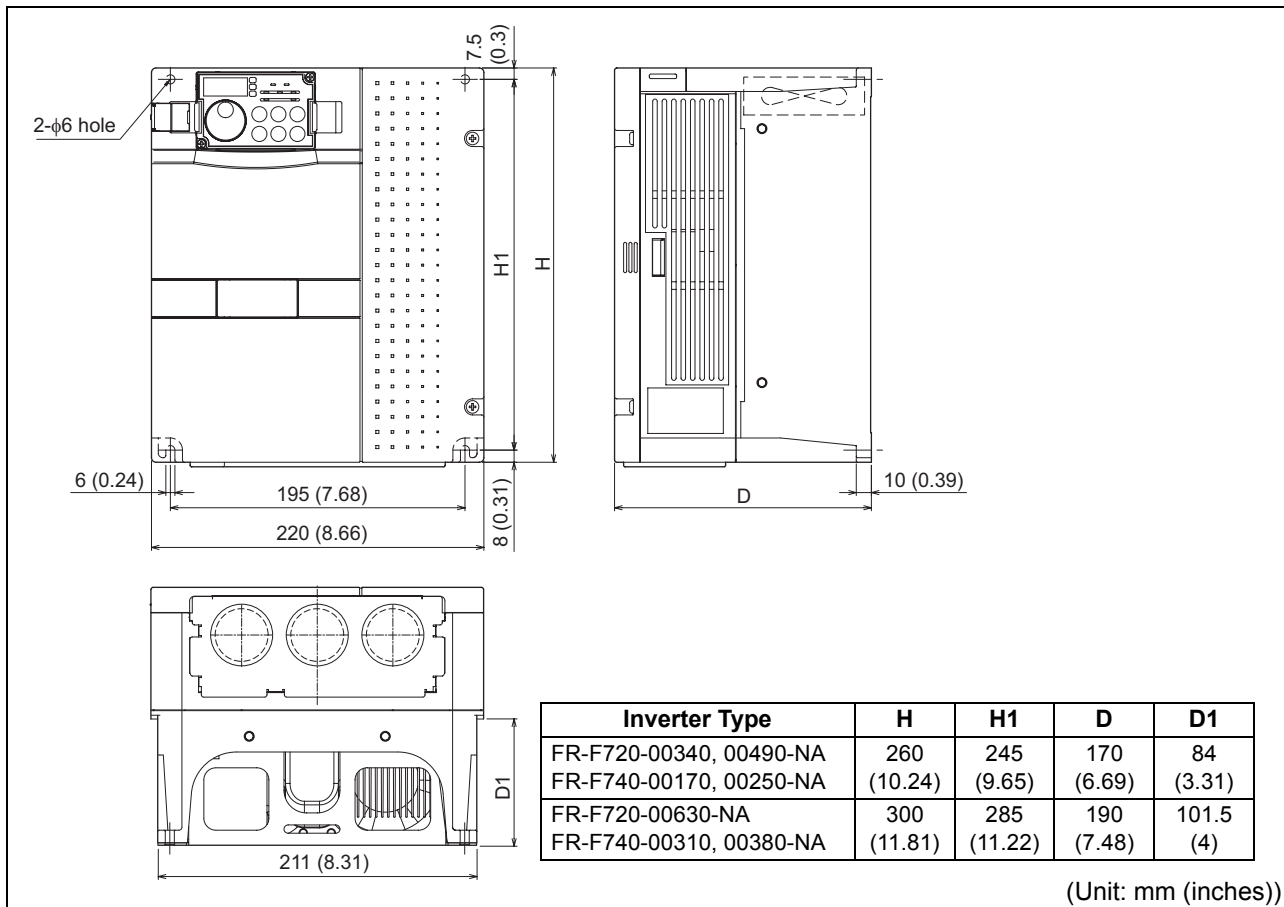

- FR-F720-00770, 00930, 01250-NA
- FR-F740-00470, 00620-NA

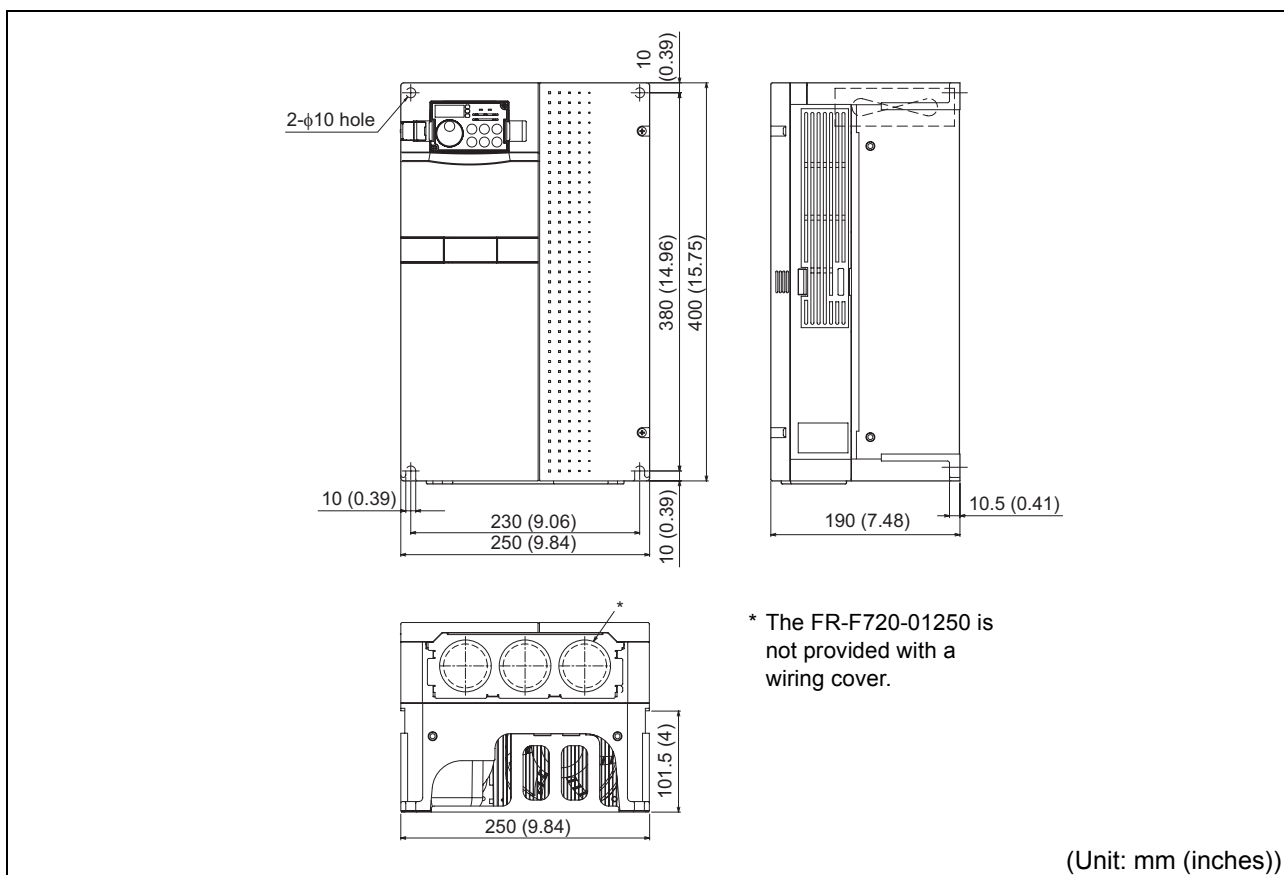



- FR-F720-01540, 01870, 02330-NA
- FR-F740-00770, 00930, 01160-NA

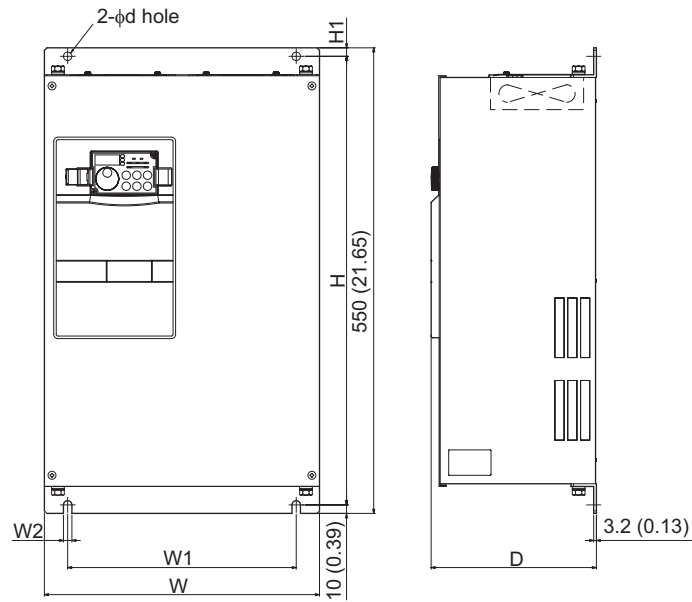

Inverter Type	W	W1	W2	H	H1	d	D
FR-F720-01540-NA FR-F740-00770-NA	325 (12.8)	270 (10.63)	10 (0.39)	530 (20.87)	10 (0.39)	10 (0.39)	195 (7.68)
FR-F720-01870, 02330-NA FR-F740-00930, 01160-NA	435 (17.13)	380 (14.96)	12 (0.47)	525 (20.67)	15 (0.59)	12 (0.47)	250 (9.84)

(Unit: mm (inches))

• FR-F740-01800-NA

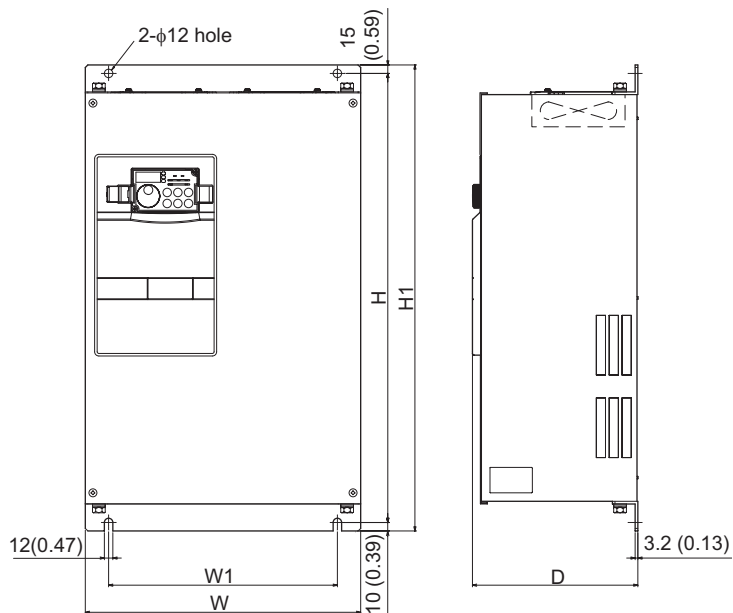

Inverter Type	W	W1	H	H1	D
FR-F740-01800-NA	435 (17.13)	380 (14.96)	525 (20.67)	550 (21.65)	250 (9.84)

(Unit: mm (inches))

• DC reactor supplied

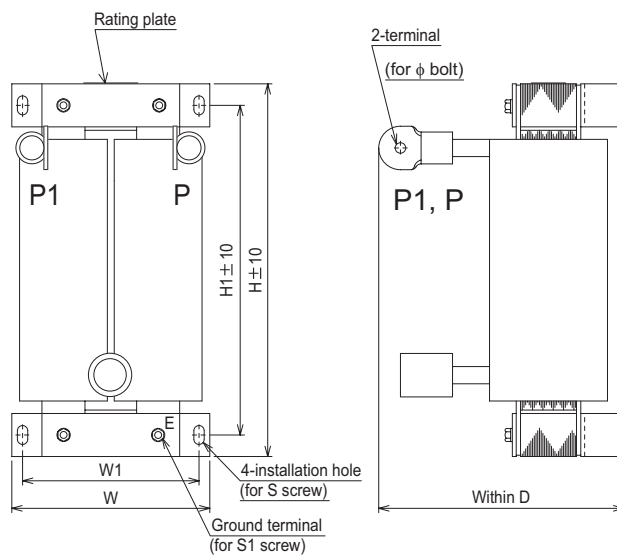

Inverter Type	W	W1	H	H1	D	S	S1	φ	Mass (kg(lbs))
FR-F740-01800-NA(FR-HEL-H90K)	150 (5.91)	130 (5.12)	340 (13.39)	310 (12.20)	190 (7.48)	M6	M6	M12	20 (44)

(Unit: mm (inches))



- FR-F720-03160, 03800, 04750-NA
- FR-F740-02160, 02600, 03250, 03610-NA

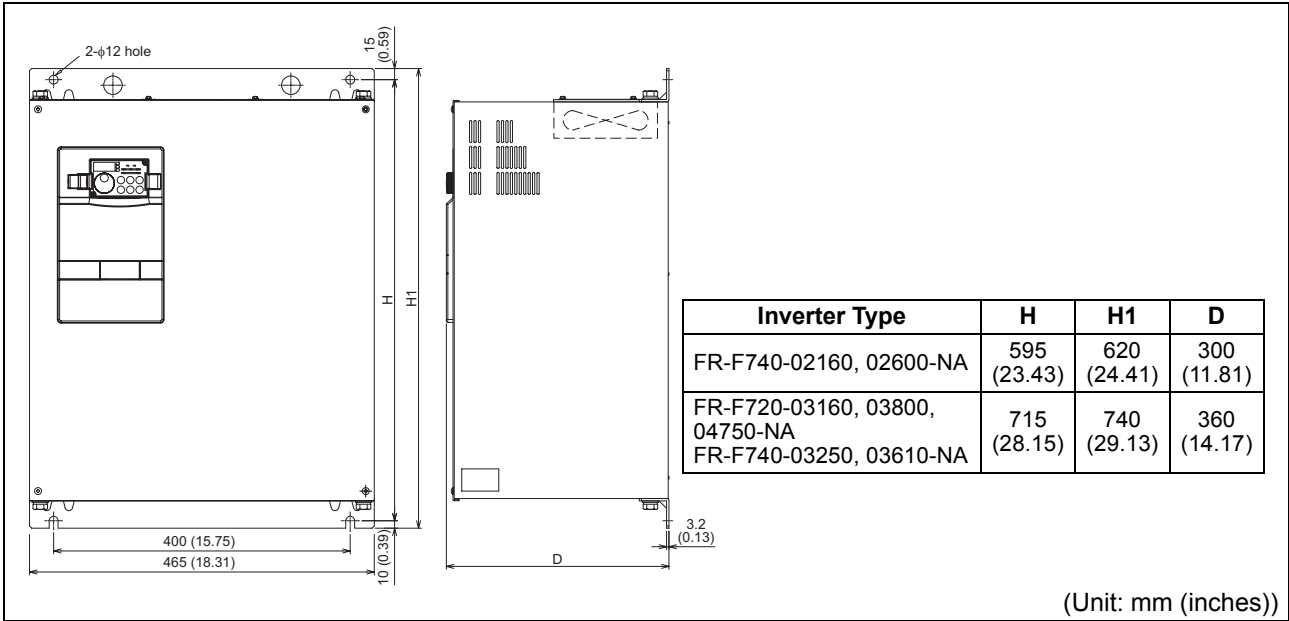

- DC reactor supplied

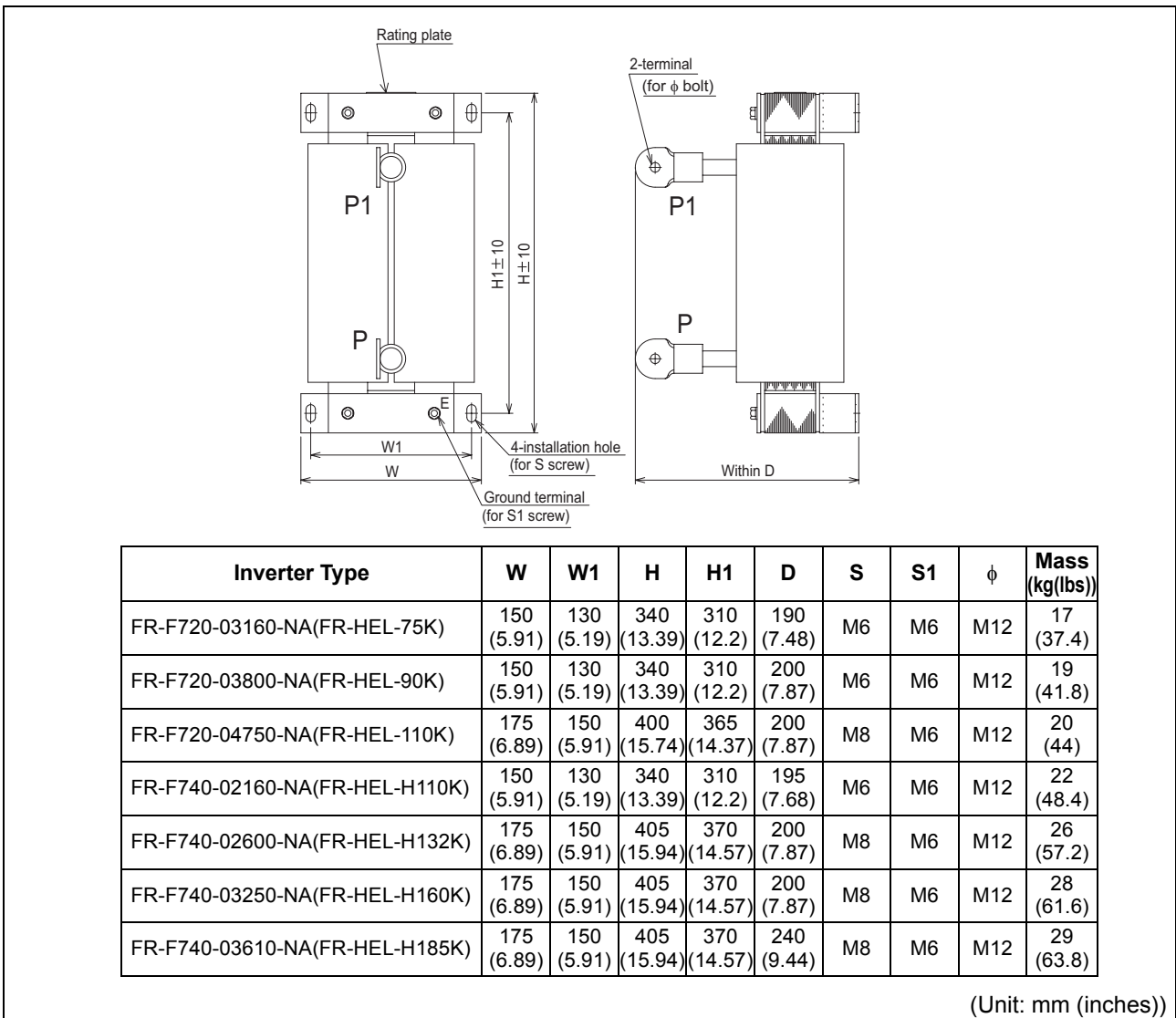

• FR-F740-04320, 04810, 05470, 06100, 06830-NA

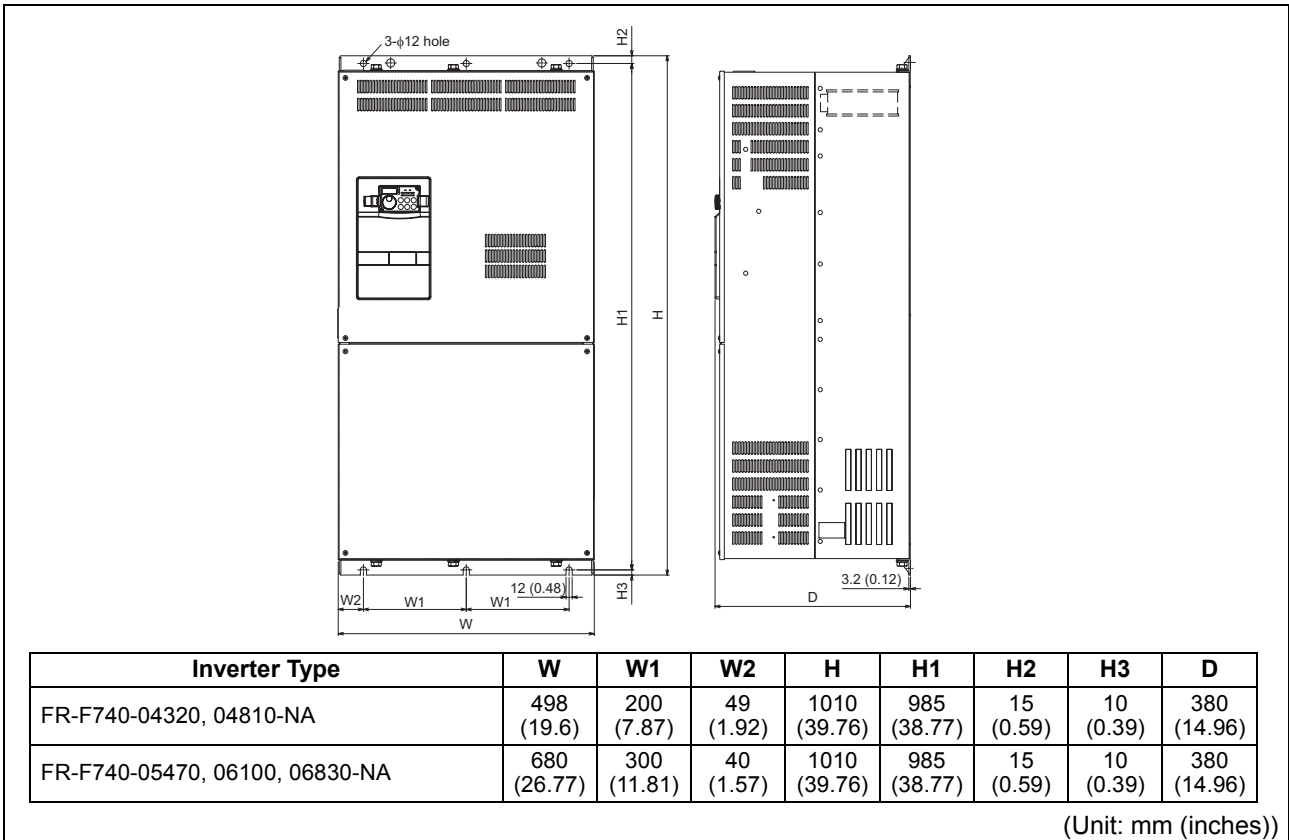

• DC reactor supplied

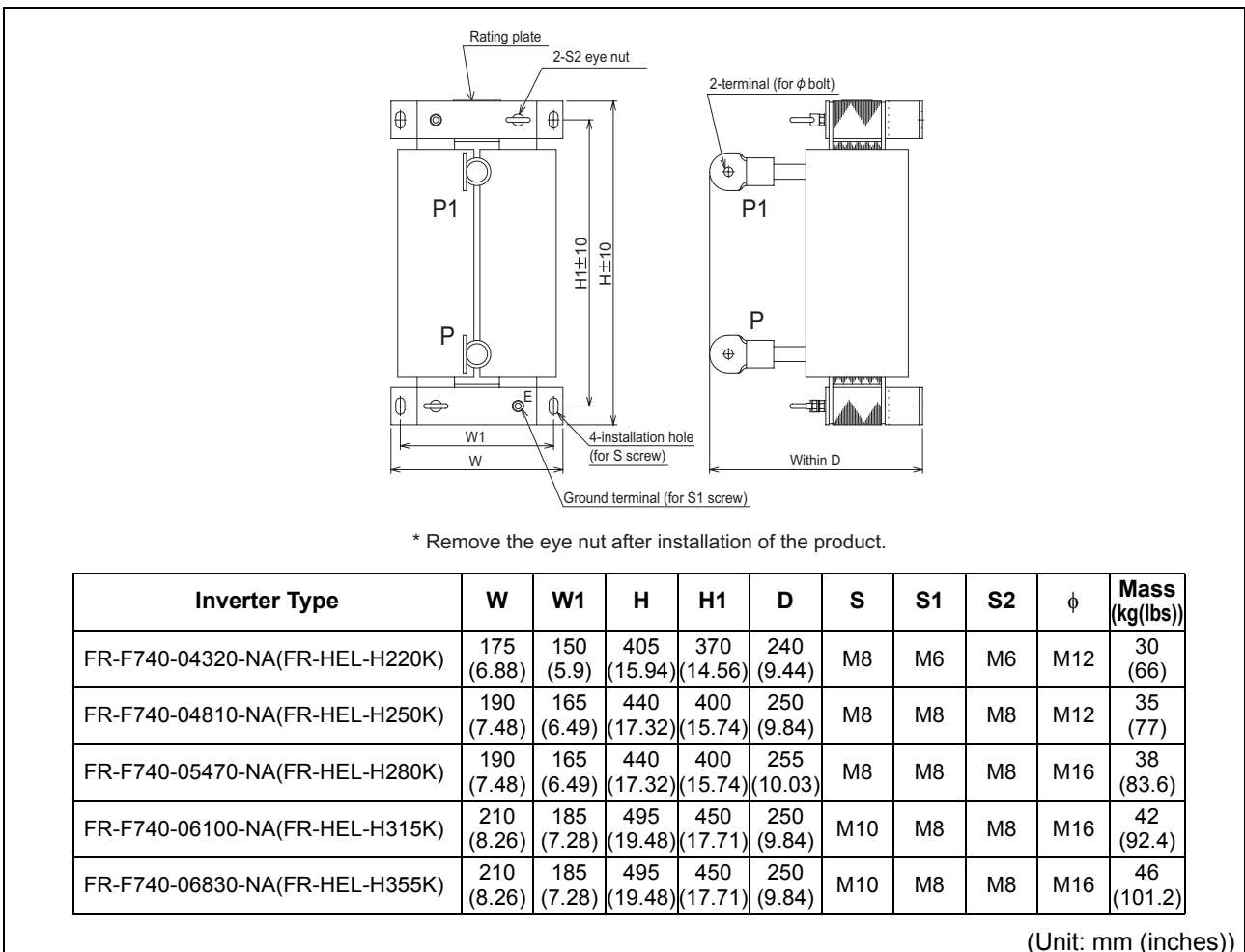



• FR-F740-07700, 08660-NA

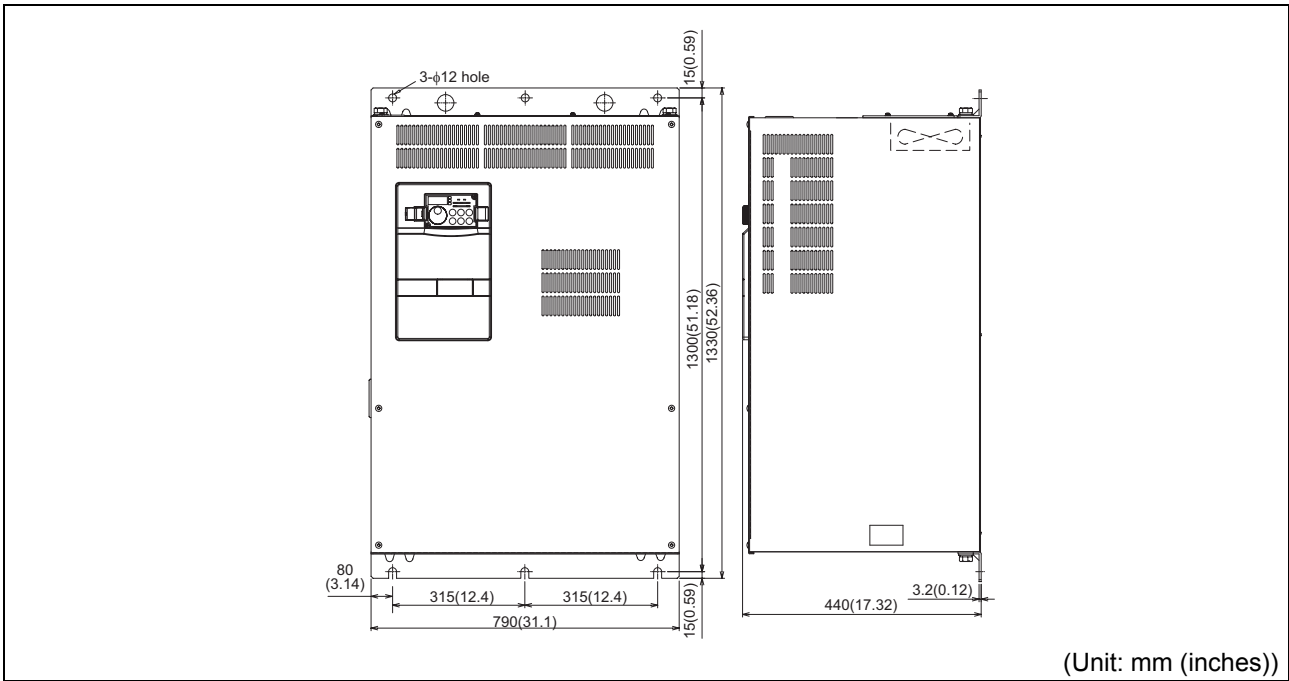

• DC reactor supplied

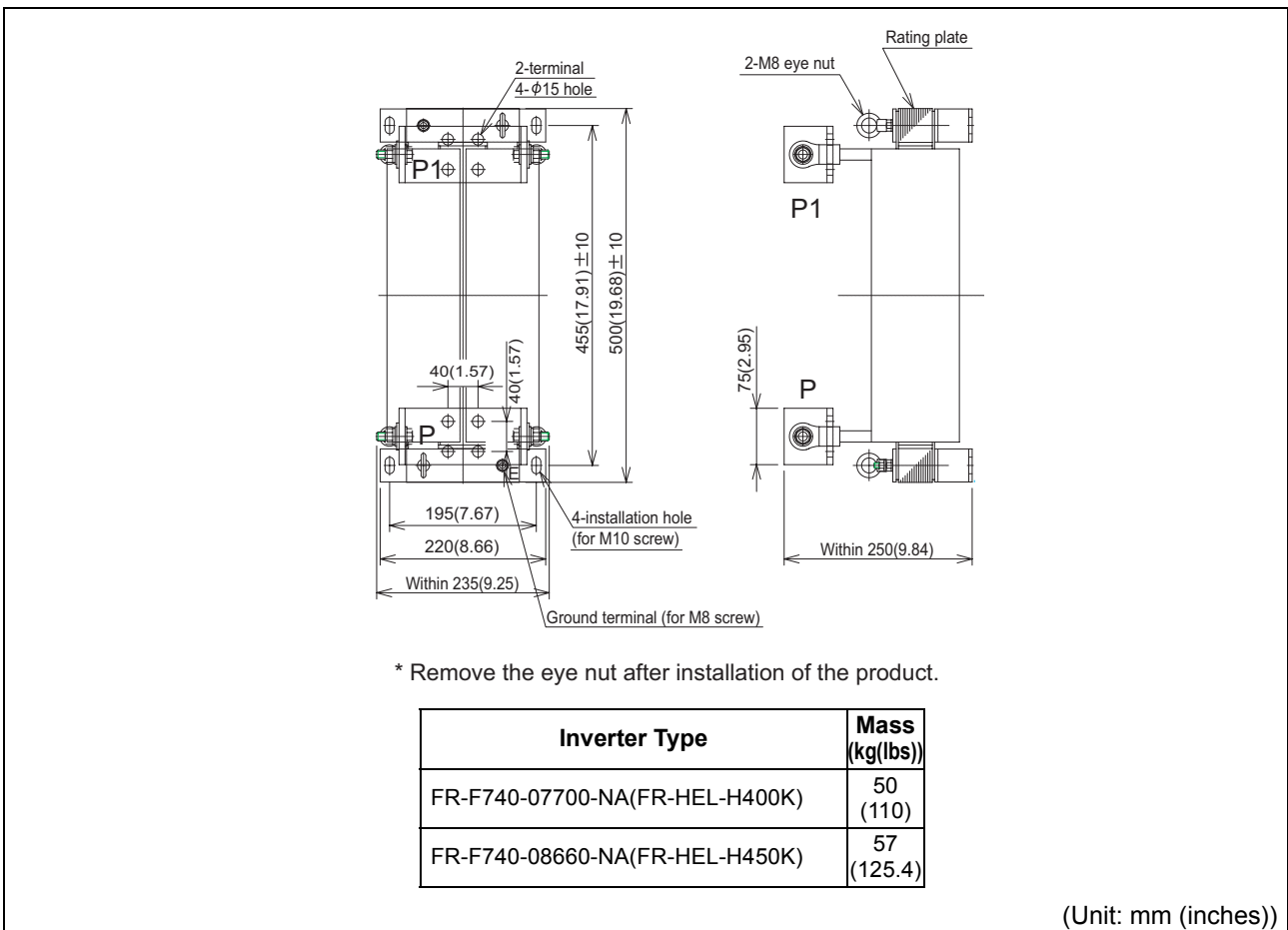

• FR-F740-09620, 10940, 12120-NA

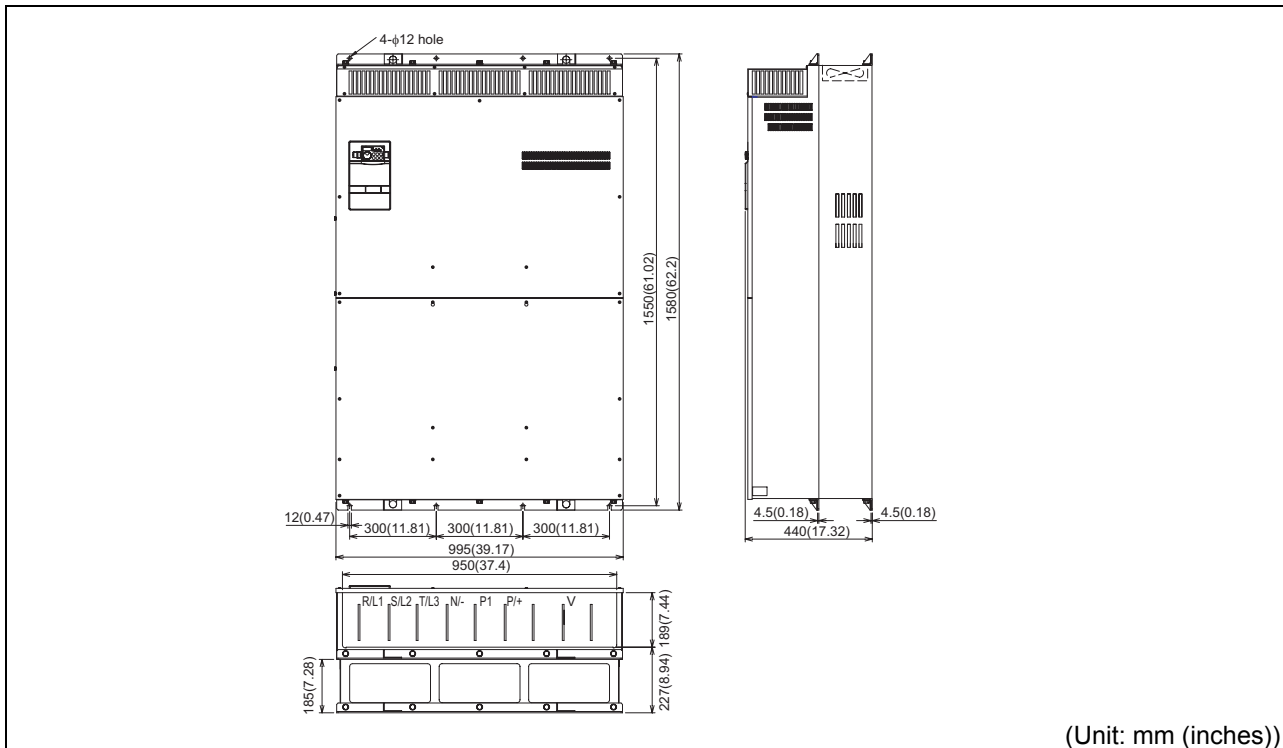

• DC reactor supplied

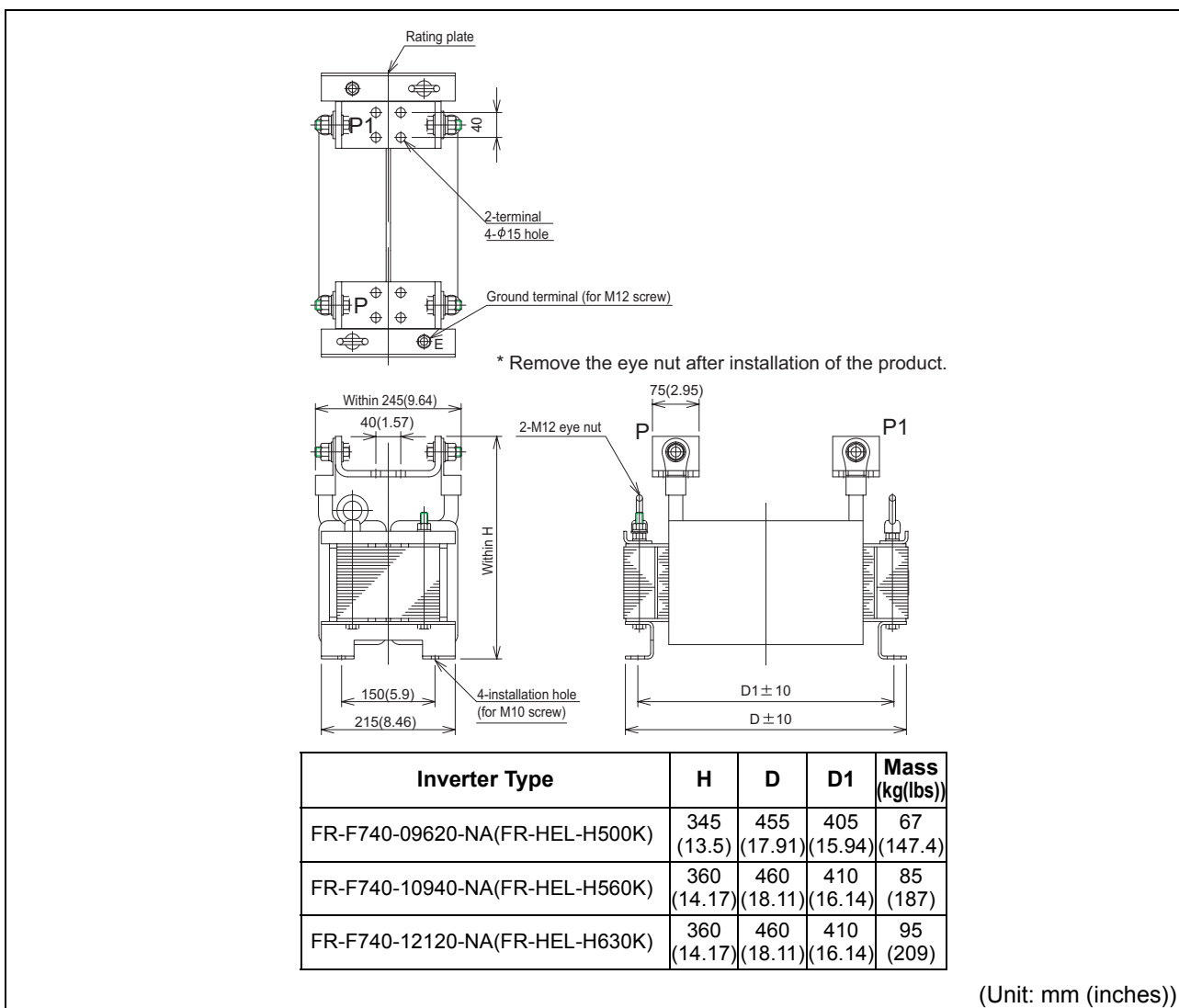



7.3.2 Operation panel (FR-DU07) outline dimension drawings

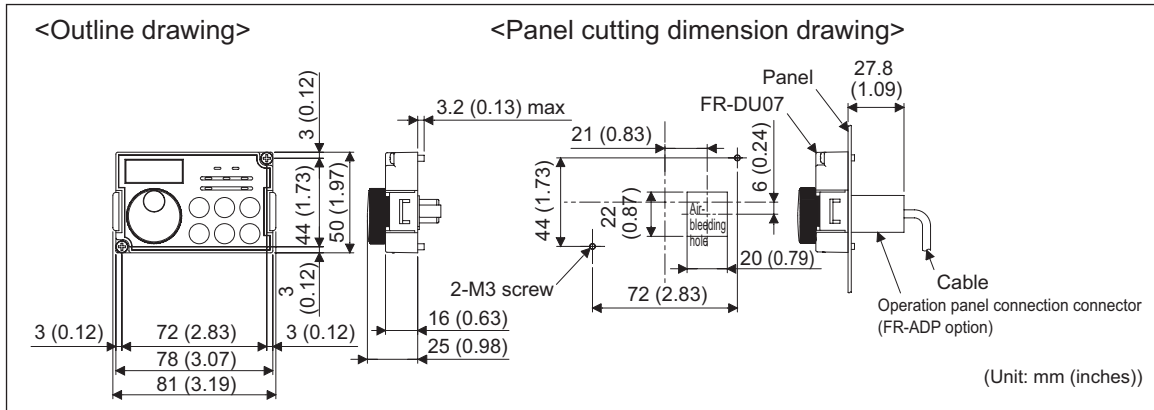

7.3.3 Parameter unit (FR-PU04) outline dimension drawings

• FR-PU04

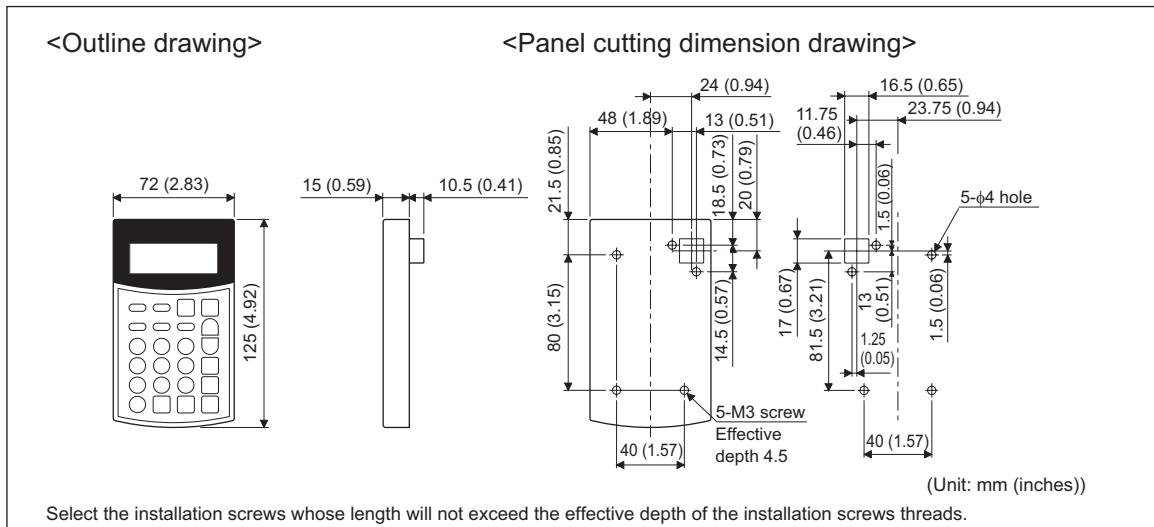

APPENDICES

Appendix 1 List of parameters classified by purpose of use

Set the parameters according to the operating conditions. The following list indicates purpose of use and corresponding parameters.

	Purpose of Use	Parameter Number
Adjust the output torque of the motor (current)	Manual torque boost	Pr. 0, Pr. 46
	Simple magnetic flux vector control	Pr. 80, Pr. 90
	Slip compensation	Pr. 246 to Pr. 247
	Stall prevention operation	Pr. 22, Pr. 23, Pr. 48, Pr. 49, Pr. 66, Pr. 148, Pr. 149, Pr. 154, Pr. 156, Pr. 157
	Multiple rating setting	Pr. 570
Limit the output frequency	Maximum/minimum frequency	Pr. 1, Pr. 2, Pr. 18
	Avoid mechanical resonance points (frequency jump)	Pr. 31 to Pr. 36
Set V/F pattern	Base frequency, voltage	Pr. 3, Pr. 19, Pr. 47
	V/F pattern matching applications	Pr. 14
	Adjustable 5 points V/F	Pr. 71, Pr. 100 to Pr. 109
Frequency setting with terminals	Multi-speed setting operation	Pr. 4 to Pr. 6, Pr. 24 to Pr. 27, Pr. 232 to Pr. 239
	Jog operation	Pr. 15, Pr. 16
	Input compensation of multi-speed and remote setting	Pr. 28
	Remote setting function	Pr. 59
Acceleration/deceleration time/pattern adjustment	Acceleration/deceleration time setting	Pr. 7, Pr. 8, Pr. 20, Pr. 21, Pr. 44, Pr. 45
	Starting frequency	Pr. 13
	Acceleration/ deceleration pattern and back lash measures	Pr. 29, Pr. 140 to Pr. 143
	Regeneration avoidance functions at deceleration	Pr. 882 to Pr. 886
Selection and protection of a motor	Motor protection from overheat (electronic thermal relay function)	Pr. 9, Pr. 51
	Use the constant torque motor (applied motor)	Pr. 71
Motor brake and stop operation	DC injection brake	Pr. 10 to Pr. 12
	Selection of regeneration unit	Pr. 30, Pr. 70
	Selection of motor stopping method	Pr. 250
	Decelerate the motor to a stop at instantaneous power failure	Pr. 261 to Pr. 266
Function assignment of external terminal and control	Function assignment of input terminal	Pr. 178 to Pr. 189
	Start signal selection	Pr. 250
	Logic selection of output stop signal (MRS)	Pr. 17
	Selection of action conditions of the second function signal (RT)	Pr. 155
	Terminal assignment of output terminal	Pr. 190 to Pr. 196
	Detection of output frequency (SU, FU, FU2 signal)	Pr. 41, Pr. 42, Pr. 43, Pr. 50
	Detection of output current (Y12 signal) Detection of zero current (Y13 signal)	Pr. 150 to Pr. 153, Pr. 166, Pr. 167
	Remote output function (REM signal)	Pr. 495 to Pr. 497
Monitor display and monitor output signal	Speed display and speed setting	Pr. 37, Pr. 144
	Change of DU/PU monitor descriptions Cumulative monitor clear	Pr. 52, Pr. 170, Pr. 171, Pr. 563, Pr. 564, Pr. 891
	Change of the monitor output from terminal CA and AM	Pr. 54 to Pr. 56, Pr. 158, Pr. 867, Pr. 869
	Adjustment of terminal CA and AM (calibration)	C0 (Pr. 900), C1 (Pr. 901)
	Energy saving monitor	Pr. 891 to Pr. 899
Detection of output frequency and current	Detection of output frequency (SU, FU, FU2 signal)	Pr. 41 to Pr. 43, Pr. 50
	Detection of output current (Y12 signal) Detection of zero current (Y13 signal)	Pr. 150 to Pr. 153, Pr. 166, Pr. 167

	Purpose of Use	Parameter Number
Operation selection at power failure and instantaneous power failure	Restart operation after instantaneous power failure	Pr. 57, Pr. 58, Pr. 162 to Pr. 165, Pr. 299, Pr. 611
	Decelerate the motor to a stop at instantaneous power failure	Pr. 261 to Pr. 266
Operation setting at alarm occurrence	Retry function at alarm occurrence	Pr. 65, Pr. 67 to Pr. 69
	Output function of alarm code	Pr. 76
	Input/output phase failure protection selection	Pr. 251, Pr. 872
	Regeneration avoidance function	Pr. 882 to Pr. 886
Energy saving operation	Energy saving control selection	Pr. 60
	How much energy can be saved (energy saving monitor)	Pr. 891 to Pr. 899
Reduction of the motor noise Measures against noise and leakage currents	Carrier frequency and SoftPWM selection	Pr. 72, Pr. 240, Pr. 260
	Noise elimination at the analog input	Pr. 74
Frequency setting by analog input	Analog input selection	Pr. 73, Pr. 267, Pr. 573
	Override function	Pr. 73, Pr. 252, Pr. 253
	Noise elimination at the analog input	Pr. 74
	Change of analog input frequency, adjustment of voltage, current input and frequency (calibration)	Pr. 125, Pr. 126, Pr. 241, C2 to C7 (Pr. 902 to Pr. 905)
	Compensation at the analog input	Pr. 242, Pr. 243
Misoperation prevention and parameter setting restriction	Reset selection, disconnected PU detection	Pr. 75
	Prevention of parameter rewrite	Pr. 77
	Prevention of reverse rotation of the motor	Pr. 78
	Display necessary parameters only. (user group)	Pr. 160, Pr. 172 to Pr. 174
	Control of parameter write by communication	Pr. 342
Selection of operation mode and operation location	Operation mode selection	Pr. 79
	Operation mode when power is on	Pr. 79, Pr. 340
	Operation command source and speed command source during communication operation	Pr. 338, Pr. 339
	Selection of the NET mode operation control source	Pr. 550
	Selection of the PU mode operation control source	Pr. 551
Communication operation and setting	Communication initial setting	Pr. 117 to Pr. 124, Pr. 331 to Pr. 337, Pr. 341
	Control of parameter write by communication	Pr. 342
	ModbusRTU communication specifications	Pr. 343
	Operation command source and speed command source during communication operation	Pr. 338, Pr. 339
	Selection of the NET mode operation control source	Pr. 550
	ModbusRTU protocol (communication protocol selection)	Pr. 549
Special operation and frequency control	PID control	Pr. 127 to Pr. 134, Pr. 575 to Pr. 577
	Switch between the inverter operation and commercial power-supply operation to use	Pr. 135 to Pr. 139, Pr. 159
	Pump function	Pr.575 to Pr.591
	Regeneration avoidance function	Pr. 882 to Pr. 886
Useful functions	Free parameter	Pr. 888, Pr. 889
	Increase cooling fan life	Pr. 244
	To determine the maintenance time of parts.	Pr. 255 to Pr. 259, Pr. 503, Pr. 504
	How much energy can be saved (energy saving monitor)	Pr. 60, Pr. 891 to Pr. 899
Setting from the parameter unit and operation panel	Parameter unit language switchover	Pr. 145
	Operation selection of the operation panel	Pr. 161
	Buzzer control of the operation panel	Pr. 990
	Contrast adjustment of the parameter unit	Pr. 991

Appendix 2 Extended parameters

⊙ indicates simple mode parameters.

Function	Parameter	Name	Increments	Initial Value	Range	Description	Parameter copy	Parameter clear	All parameter clear																								
							⊙ : enabled × : disabled																										
Manual torque boost	0 ⊙	Torque boost	0.1%	6/4/3/2/ 1.5/1% *1	0 to 30%	Set the output voltage at 0Hz as %. *1 Initial values differ according to the inverter capacity. <table border="1" style="width: 100%; border-collapse: collapse; margin-top: 5px;"> <thead> <tr> <th colspan="2">Inverter capacity</th> <th>Initial value</th> </tr> <tr> <th>200V class</th> <th>400V class</th> <th></th> </tr> </thead> <tbody> <tr> <td>00046</td> <td>00023</td> <td>6%</td> </tr> <tr> <td>00077 to 00167</td> <td>00038 to 00083</td> <td>4%</td> </tr> <tr> <td>00250, 00340</td> <td>00126, 00170</td> <td>3%</td> </tr> <tr> <td>00490 to 01540</td> <td>00250 to 00770</td> <td>2%</td> </tr> <tr> <td>01870, 02330</td> <td>00930, 01160</td> <td>1.5%</td> </tr> <tr> <td>03160 or more</td> <td>01800 or more</td> <td>1%</td> </tr> </tbody> </table>	Inverter capacity		Initial value	200V class	400V class		00046	00023	6%	00077 to 00167	00038 to 00083	4%	00250, 00340	00126, 00170	3%	00490 to 01540	00250 to 00770	2%	01870, 02330	00930, 01160	1.5%	03160 or more	01800 or more	1%	○	○	○
	Inverter capacity		Initial value																														
200V class	400V class																																
00046	00023	6%																															
00077 to 00167	00038 to 00083	4%																															
00250, 00340	00126, 00170	3%																															
00490 to 01540	00250 to 00770	2%																															
01870, 02330	00930, 01160	1.5%																															
03160 or more	01800 or more	1%																															
	46	Second torque boost	0.1%	9999	0 to 30% 9999	Set the torque boost when the RT signal is on. Without second torque boost	○	○	○																								
Maximum/minimum frequency	1 ⊙	Maximum frequency	0.01Hz	120/ 60Hz*2	0 to 120Hz	Set the upper limit of the output frequency. *2 The setting depends on the inverter capacity (FR-F720-02330 (FR-F740-01160) or less/FR-F720-03160 (FR-F740-01800) or more)	○	○	○																								
	2 ⊙	Minimum frequency	0.01Hz	0Hz	0 to 120Hz	Set the lower limit of the output frequency.	○	○	○																								
	18	High speed maximum frequency	0.01Hz	120/ 60Hz*3	120 to 400Hz	Set when performing the operation at 120Hz or more. *3 The setting depends on the inverter capacity (FR-F720-02330 (FR-F740-01160) or less/FR-F720-03160 (FR-F740-01800) or more)	○	○	○																								
Base frequency, voltage	3 ⊙	Base frequency	0.01Hz	60Hz	0 to 400Hz	Set the frequency when the motor rated torque is generated. (50Hz/60Hz)	○	○	○																								
	19	Base frequency voltage	0.1V	9999	0 to 1000V 8888 9999	Set the base voltage. 95% of power supply voltage Same as power supply voltage	○	○	○																								
	47	Second V/F (base frequency)	0.01Hz	9999	0 to 400Hz 9999	Set the base frequency when the RT signal is on. Second V/F is invalid	○	○	○																								
Multi-speed setting operation	4 ⊙	Multi-speed setting (high speed)	0.01Hz	60Hz	0 to 400Hz	Set frequency when the RT signal is on.	○	○	○																								
	5 ⊙	Multi-speed setting (middle speed)	0.01Hz	30Hz	0 to 400Hz	Set frequency when the RM signal is on.	○	○	○																								
	6 ⊙	Multi-speed setting (low speed)	0.01Hz	10Hz	0 to 400Hz	Set frequency when the RL signal is on.	○	○	○																								
	24 to 27	Multi-speed setting 4 speed to 7 speed	0.01Hz	9999	0 to 400Hz, 9999	Frequency from 4 speed to 15 speed can be set according to the combination of the RH, RM, RL and REX signals. 9999: not selected	○	○	○																								
	232 to 239	Multi-speed setting 8 speed to 15 speed	0.01Hz	9999	0 to 400Hz, 9999		○	○	○																								

Function	Parameter		Name	Increments	Initial Value	Range	Description	Parameter copy	Parameter clear	All parameter clear							
	Related parameters																
								O : enabled × : disabled									
Acceleration/deceleration time setting	7	☉	Acceleration time	0.1/ 0.01s	5/15s *4	0 to 3600/ 360s	Set the motor acceleration time. *4 Initial values differ according to the inverter capacity. (FR-F720-00340 (FR-F740-00170) or less/FR-F720-00490 (FR-F740-00250) or more)	○	○	○							
	8	☉	Deceleration time	0.1/ 0.01s	10/30s *5	0 to 3600/ 360s	Set the motor deceleration time. *5 Initial values differ according to the inverter capacity. (FR-F720-00340 (FR-F740-00170) or less/FR-F720-00490 (FR-F740-00250) or more)	○	○	○							
		20	Acceleration/ deceleration reference frequency	0.01Hz	60Hz	1 to 400Hz	Set the frequency referenced as acceleration/deceleration time. As acceleration/deceleration time, set the frequency change time from stop to Pr. 20.	○	○	○							
		21	Acceleration/ deceleration time increments	1	0	0	Increments: 0.1s Range: 0 to 3600s	Increments and setting range of acceleration/ deceleration time setting can be changed.	○	○	○						
						1						Increments: 0.01s Range: 0 to 360s					
		44	Second acceleration/ deceleration time	0.1/ 0.01s	5s	0 to 3600/ 360s	Set the acceleration/deceleration time when the RT signal is on.	○	○	○							
45	Second deceleration time	0.1/ 0.01s	9999	0 to 3600/ 360s	Set the deceleration time when the RT signal is on.	○	○	○									
				9999	Acceleration time = deceleration time												
Motor protection from overheat (electronic thermal relay function)	9	☉	Electronic thermal O/L relay	0.01/ 0.1A *6	Rated inverter output current	0 to 500/ 0 to 3600A *6	Set the rated motor current. *6 The setting depends on the inverter capacity (FR-F720-02330 (FR-F740-01160) or less/FR-F720-03160 (FR-F740-01800) or more)	○	○	○							
						51	Second electronic thermal O/L relay				0.01/ 0.1A *7	9999	0 to 500A 0 to 3600A *7	Made valid when the RT signal is on. Set the rated motor current. *7 The setting depends on the inverter capacity (FR-F720-02330 (FR-F740-01160) or less/FR-F720-03160 (FR-F740-01800) or more)	○	○	○
													9999	Second electronic thermal O/L relay invalid			
DC injection brake	10		DC injection brake operation frequency	0.01Hz	3Hz	0 to 120Hz	Set the operation frequency of the DC injection brake.	○	○	○							
						9999	Operate when the output frequency becomes less than or equal to Pr.13 Starting frequency.										
	11		DC injection brake operation time	0.1s	0.5s	0	DC injection brake disabled	○	○	○							
						8888	Operate DC injection brake for the time X13 signal is on.										
	12		DC injection brake operation voltage	0.1%	4/2/1% *8	0	DC injection brake disabled	○	○	○							
						0.1 to 30%	Set the DC injection brake voltage (torque). *8 Initial values differ according to the inverter capacity. (FR-F720-00340 (FR-F740-00170) or less/FR-F720-00490 to 02330 (FR-F740-00250 to 01160)/FR-F720-03160 (FR-F740-01800) or more)										
Starting frequency	13		Starting frequency	0.01Hz	0.5Hz	0 to 60Hz	Starting frequency can be set.	○	○	○							
						571	Holding time at a start				0.1s	9999	0.0 to 10.0s	Set the holding time of Pr.13 Starting frequency.	○	○	○
													9999	Holding function at a start is invalid			

Function	Parameter	Name	Increments	Initial Value	Range	Description	Parameter copy	Parameter clear	All parameter clear
							O : enabled × : disabled		
V/F pattern matching applications	14	Load pattern selection	1	1	0	For constant torque load	○	○	○
					1	For variable-torque load			
Jog operation	15	Jog frequency	0.01Hz	5Hz	0 to 400Hz	Set the frequency for jog operation.	○	○	○
	16	Jog acceleration/ deceleration time	0.1/ 0.01s	0.5s	0 to 3600/ 360s	Set the acceleration/deceleration time for jog operation. Set the time taken to reach the frequency set in <i>Pr.20 Acceleration/ deceleration reference frequency</i> for acceleration/deceleration time. (Initial value is 60Hz) In addition, acceleration/deceleration time can not be set separately.	○	○	○
Logic selection of output stop signal (MRS)	17	MRS input selection	1	0	0	Open input always	○	○	○
					2	Normally closed input (NC contact input specifications)			
—	18	Refer to <i>Pr.1 and Pr.2.</i>							
	19	Refer to <i>Pr.3.</i>							
	20,21	Refer to <i>Pr.7 and Pr.8.</i>							
Stall prevention operation	22	Stall prevention operation level	0.1%	110%	0	Stall prevention operation selection becomes invalid.	○	○	○
					0.1 to 120%	Set the current value at which stall prevention operation is started.			
					9999	Analog variable			
	23	Stall prevention operation level compensation factor at double speed	0.1%	9999	0 to 150%	The stall operation level can be reduced when operating at a high speed above the rated frequency.	○	○	○
					9999	Constant according to Pr.22			
	48	Second stall prevention operation current	0.1%	110%	0	Second stall prevention operation invalid	○	○	○
					0.1 to 120%	The stall prevention operation level can be set.			
	49	Second stall prevention operation frequency	0.01Hz	0Hz	0	Second stall prevention operation invalid	○	○	○
					0.01 to 400Hz	Set the frequency at which stall prevention operation of Pr. 48 is started.			
	9999	Pr.48 is valid when the RT signal is on.							
	66	Stall prevention operation reduction starting frequency	0.01Hz	60Hz	0 to 400Hz	Set the frequency at which the stall operation level is started to reduce.	○	○	○
	148	Stall prevention level at 0V input.	0.1%	110%	0 to 120%	Stall prevention operation level can be changed by the analog signal input to terminal 1.	○	○	○
149	Stall prevention level at 10V input.	0.1%	120%	0 to 120%	○		○	○	
154	Voltage reduction selection during stall prevention operation	1	1	0	With voltage reduction	○	○	○	
				1	Without voltage reduction				You can select whether to use output voltage reduction during stall prevention operation or not.
156	Stall prevention operation selection	1	0	0 to 31, 100, 101	<i>Pr. 156</i> allows you to select whether to use stall prevention or not according to the acceleration/deceleration status.	○	○	○	
157	OL signal output timer	0.1s	0s	0 to 25s	Set the output start time of the OL signal output when stall prevention is activated.	○	○	○	
				9999	Without the OL signal output				
—	24 to 27	Refer to <i>Pr. 4 to Pr. 6.</i>							

Function	Parameter		Name	Increments	Initial Value	Range	Description	Parameter copy	Parameter clear	All parameter clear	
	Related parameters							O: enabled ×: disabled			
Input compensation of multi-speed and remote setting		28		Multi-speed input compensation selection	1	0	0	Without compensation	○	○	○
	1						With compensation				
Acceleration/ deceleration pattern and backlash	29		Acceleration/ deceleration pattern selection	1	0	0	Linear acceleration/ deceleration	○	○	○	
						1	S-pattern acceleration/deceleration A				
						2	S-pattern acceleration/deceleration B				
						3	Backlash measures				
	140	Backlash acceleration stopping frequency	0.01Hz	1Hz	0 to 400Hz	Set the stopping frequency and time for backlash measures. Valid when Pr.29="3"	○	○	○		
	141	Backlash acceleration stopping time	0.1s	0.5s	0 to 360s		○	○	○		
142	Backlash deceleration stopping frequency	0.01Hz	1Hz	0 to 400Hz	○		○	○			
143	Backlash deceleration stopping time	0.1s	0.5s	0 to 360s	○		○	○			
Selection of regeneration unit	30		Regenerative function selection	1	0	0	FR-F720-02330 (FR-F740-01160) or less Brake unit	FR-F720-03160 (FR-F740-01800) or more Without regenerative function	○	○	○
						1	Setting can not be made.	Brake unit, Power regeneration converter			
						2	High power factor converter, power regeneration common converter	High power factor converter			
	70		Special regenerative brake duty	0.1%	0%	0 to 10%	You can set the brake duty when a brake unit or power regeneration converter is used. Setting can be made for the FR-F720-03160 (FR-F740-01800) or more.	○	○	○	
Avoid mechanical resonance points (frequency jump)	31		Frequency jump 1A	0.01Hz	9999	0 to 400Hz, 9999	1A to 1B, 2A to 2B, 3A to 3B is frequency jumps 9999: Function invalid	○	○	○	
	32		Frequency jump 1B	0.01Hz	9999	0 to 400Hz, 9999		○	○	○	
	33		Frequency jump 2A	0.01Hz	9999	0 to 400Hz, 9999		○	○	○	
	34		Frequency jump 2B	0.01Hz	9999	0 to 400Hz, 9999		○	○	○	
	35		Frequency jump 3A	0.01Hz	9999	0 to 400Hz, 9999		○	○	○	
	36		Frequency jump 3B	0.01Hz	9999	0 to 400Hz, 9999		○	○	○	
Speed display and speed setting	37		Speed display	1	0	0	Frequency display, setting	○	○	○	
						1 to 9998	Set the machine speed at 60Hz.				
	144		Speed setting switchover	1	4	0, 2, 4, 6, 8, 10, 102, 104, 106, 108, 110	Set the number of motor poles when displaying the motor speed.	○	○	○	

Function	Parameter	Name	Increments	Initial Value	Range	Description	Parameter copy	Parameter clear	All parameter clear
							O : enabled × : disabled		
Detection of output frequency (SU, FU, FU2 signal)	41	Up-to-frequency sensitivity	0.1%	10%	0 to 100%	Set the level where the SU signal turns on.	O	O	O
	42	Output frequency detection	0.01Hz	6Hz	0 to 400Hz	Set the frequency where the FU signal turns on.	O	O	O
	43	Output frequency detection for reverse rotation	0.01Hz	9999	0 to 400Hz	Set the frequency where the FU signal turns on in reverse rotation.	O	O	O
					9999	Same as Pr.42 setting			
50	Second output frequency detection	0.01Hz	30Hz	0 to 400Hz	Set the frequency where the FU2 signal turns on.	O	O	O	
—	44, 45	Refer to Pr. 7 and Pr. 8.							
	46	Refer to Pr. 0.							
	47	Refer to Pr. 3.							
	48, 49	Refer to Pr. 22 and Pr. 23.							
—	50	Refer to Pr. 41 to Pr. 43.							
	51	Refer to Pr. 9.							
Change of DU/PU monitor descriptions Cumulative monitor clear	52	DU/PU main display data selection	1	0	0, 5, 6, 8 to 14, 17, 20, 23 to 25, 50 to 57, 100	Select the monitor to be displayed on the operation panel and parameter unit. The setting value of "9" is available only for the FR-F720-03160 (FR-F740-01800) or more.	O	O	O
					0	Set "0" to clear the watt-hour meter monitor.			
	170	Cumulative power meter clear	1	9999	10	Set the maximum value when monitoring from communication to 0 to 9999kWh.	×	×	O
					9999	Set the maximum value when monitoring from communication to 0 to 65535kWh.			
	171	Operation hour meter clear	1	9999	0, 9999	Set "0" in the parameter to clear the watt-hour monitor. Setting "9999" has no effect.	×	×	×
	268	Monitor decimal digits selection	1	9999	0	Displays the monitor as integral value.	O	O	O
					1	Displays the monitor in increments of 0.1.			
	9999	No fixed decimal position							
	563	Energization time carrying-over times	1	0	0 to 65535	The numbers of cumulative energization time monitor exceeded 65535h is displayed. Reading only	×	×	×
	564	Operating time carrying-over times	1	0	0 to 65535	The numbers of operation time monitor exceeded 65535h is displayed. Reading only	×	×	×
891	Cumulative power monitor digit shifted times	1	9999	0 to 4	Set the number of times to shift the cumulative power monitor digit Clamp the monitor value at maximum.	O	O	O	
				9999	No shift Clear the monitor value when it exceeds the maximum value.				
Change of the monitor output from terminal and AM	54	CA terminal function selection	1	1	1 to 3, 5, 6, 8 to 14, 17, 21, 24, 50, 52, 53	Select the monitor output to terminal CA. The setting value of "9" is available only for the FR-F720-03160 (FR-F740-01800) or more.	O	O	O
	55	Frequency monitoring reference	0.01Hz	60Hz	0 to 400Hz	Set the full-scale value to output the output frequency monitor value to terminal CA and AM.	O	O	O
	56	Current monitoring reference	0.01/ 0.1A *9	Rated inverter output current	0 to 500/ 0 to 3600A *9	Set the full-scale value to output the output current monitor value to terminal CA and AM. *9 The setting depends on the inverter capacity (FR-F720-02330 (FR-F740-01160) or less/FR-F720-03160 (FR-F740-01800) or more)	O	O	O
					1 to 3, 5, 6, 8 to 14, 17, 21, 24, 50, 52, 53	Select the monitor output to terminal AM. The setting value of "9" is available only for the FR-F720-03160 (FR-F740-01800) or more.			
					867	AM output filter			
869	Current output filter	0.01s	0.02s	0 to 5s	Adjust response level of current output.	O	O	O	

Function	Parameter		Name	Increments	Initial Value	Range	Description	Parameter copy	Parameter clear	All parameter clear								
	Related parameters																	
								O : enabled × : disabled										
Restart operation after instantaneous power failure	57		Restart coasting time	0.1s	9999	0	The coasting time is as follows: 200V class(400V class) 00077 or less(00038 or less) 0.5s, 00105 to 00340(00052 to 00170) . 1.0s, 00490 to 02330(00250 to 01160)... 3.0s, 03160 (01800) or more 5.0s	○	○	○								
						0.1 to 5s/ 0.1 to 30s *10	Set the waiting time for inverter-triggered restart after an instantaneous power failure. *10 The setting depends on the inverter capacity (FR-F720-02330 (FR-F740-01160) or less/FR-F720-03160 (FR-F740-01800) or more)											
						9999	No restart											
	58			Restart cushion time	0.1s	1s	0 to 60s	Set a voltage starting time at restart.	○	○	○							
							162	Automatic restart after instantaneous power failure selection				1	0	0	With frequency search			
														1	Without frequency search (Reduced voltage method)			
														10	Frequency search at every start			
														11	Reduced voltage method at every start			
							163	First cushion time for restart				0.1s	0s	0 to 20s	Set a voltage starting time at restart. Consider according to the magnitude of load (inertia moment/torque).	○	○	○
							164	First cushion voltage for restart				0.1%	0%	0 to 100%		○	○	○
	165	Stall prevention operation level for restart	0.1%	110%	0 to 120%	Consider the rated inverter current as 100% and set the stall prevention operation level during restart operation.	○	○	○									
	299			Rotation direction detection selection at restarting	1	9999	0	without rotation direction detection	○	○	○							
1							with rotation direction detection											
9999							When Pr: 78="0", the rotation direction is detected. When Pr: 78="1","2", the rotation direction is not detected.											
611			Acceleration time at a restart	0.1s	5/15s *11	0 to 3600s	Set the acceleration time to reach the set frequency at a restart. *11 The setting depends on the inverter capacity (FR-F720-02330 (FR-F740-01160) or less/FR-F720-03160 (FR-F740-01800) or more)	○	○	○								
						9999	Acceleration time for restart is the normal acceleration time (e.g. Pr: 7).											
Remote setting function	59		Remote function selection	1	0	0	RH, RM, RL signal function Multi-speed setting	Frequency setting storage function —	○	○	○							
						1	Remote setting	Yes										
						2	Remote setting	No										
						3	Remote setting	No (Turning STF/STR off clears remotely-set frequency.)										
Energy saving control selection	60	☉	Energy saving control selection	1	0	0	Normal operation mode	○	○	○								
						4	Energy saving operation mode											
						9	Optimum excitation control mode											

Function	Parameter		Name	Increments	Initial Value	Range	Description	Param eter copy	Param eter clear	All param eter clear
	Related parameters	O: enabled ×: disabled								
Retry function at alarm occurrence		65	Retry selection	1	0	0 to 5	An alarm for retry can be selected.	O	O	O
	67		Number of retries at alarm occurrence	1	0	0	No retry function	O	O	O
		1 to 10				Set the number of retries at alarm occurrence. An alarm output is not provided during retry operation.				
		101 to 110				Set the number of retries at alarm occurrence. (The setting value minus 100 is the number of retries.) An alarm output is provided during retry operation.				
	68	Retry waiting time	0.1s	1s	0 to 10s	Set the waiting time from when an inverter alarm occurs until a retry is made.	O	O	O	
69	Retry count display erase	1	0	0	Clear the number of restarts succeeded by retry.	O	O	O		
—	66	Refer to Pr.22 and Pr.23.								
—	67 to 69	Refer to Pr.65.								
—	70	Refer to Pr.30.								
Use the constant torque motor (applied motor)	71	Applied motor	1	0	0	Thermal characteristics of a standard motor	O	O	O	
					1	Thermal characteristics of the Mitsubishi constant-torque motor				
					2	Thermal characteristic of standard motor Adjustable 5 points V/F				
					20	Mitsubishi standard motor (SF-JR 4P 1.5kW or less)				
Carrier frequency and SoftPWM selection	72	PWM frequency selection	1	2	0 to 15/ 0 to 6, 25 *12	PWM carrier frequency can be changed. The setting displayed is in [kHz]. Note that 0 indicates 0.7kHz, 15 indicates 14.5kHz and 25 indicates 2.5kHz. *12 The setting depends on the inverter capacity (FR-F720-02330 (FR-F740-01160) or less/FR-F720-03160 (FR-F740-01800) or more)	O	O	O	
					240	Soft-PWM operation selection				1
	1	When Pr: 72="0 to 5" ("0 to 4" for the FR-F720-03160 (FR-F740-01800) or more), Soft-PWM is valid.								
	260	PWM frequency automatic switchover	1	1			0	PWM carrier frequency is constant independently of load. When the carrier frequency is set to 3kHz or more (Pr. 72≥3), perform continuous operation at less than 85% of the rated inverter current.		
					1	Decreases PWM carrier frequency automatically when load increases.				

Function	Parameter		Name	Increments	Initial Value	Range	Description	Parameter copy	Parameter clear	All parameter clear
	Related parameters	O: enabled ×: disabled								
Analog input selection		73		Analog input selection	1	1	0 to 7, 10 to 17	Input specification (0 to 5V, 0 to 10V) of terminal 2 and 1 can be selected. Override and reversible operation can be selected.	○	×
	242		Terminal 1 added compensation amount (terminal 2)	0.1%	100%	0 to 100%	Set the ratio of added compensation amount when terminal 2 is the main speed.	○	○	○
	243		Terminal 1 added compensation amount (terminal 4)	0.1%	75%	0 to 100%	Set the ratio of added compensation amount when terminal 4 is the main speed.	○	○	○
	252		Override bias	0.1%	50%	0 to 200%	Set the bias side compensation value of override function.	○	○	○
	253		Override gain	0.1%	150%	0 to 200%	Set the gain side compensation value of override function.	○	○	○
	267		Terminal 4 input selection	1	0	0	Terminal 4 input 4 to 20mA	○	×	○
				2		1	Terminal 4 input 0 to 5V			
573	4mA input check selection	1	9999	1	When the current input drops to or below 2mA, the LF signal is output and inverter continues operation at the frequency just before current reaches 2mA.	○	○	○		
		9999			4mA input is not checked.					
Noise elimination at the analog input	74		Input filter time constant	1	1	0 to 8	The primary delay filter time constant for the analog input can be set. A larger setting results in a larger filter.	○	○	○
Reset selection, disconnected PU detection	75		Reset selection/disconnected PU detection/PU stop selection	1	14	0 to 3, 14 to 17 100 to 103, 114 to 117*	You can select the reset input acceptance, disconnected PU (FR-DU07) connector detection function and PU stop function, and reset restriction (FR-F720-03160 (FR-F740-01800) or more). For the initial value, reset always enabled, without disconnected PU detection, with PU stop function, and without reset restriction (FR-F720-03160 (FR-F740-01800) or more) are set. * 100 to 103 and 114 to 117 can be set only for FR-F720-03160 (FR-F740-01800) or more.	○	×	×
Output function of alarm code	76		Alarm code output selection	1	0	0	Without alarm code output	○	○	○
1						With alarm code output				
Prevention of parameter rewrite	77		Parameter write selection	1	0	0	Write is enabled only during a stop	○	○	○
						1	Parameter write is disabled.			
Prevention of reverse rotation of the motor	78		Reverse rotation prevention selection	1	0	0	Both forward and reverse rotations allowed	○	○	○
						1	Reverse rotation disallowed			
						2	Forward rotation disallowed			

Function	Parameter		Name	Increments	Initial Value	Range	Description	Parameter copy	Parameter clear	All parameter clear
		Related parameters								
										O: enabled ×: disabled
Operation mode selection	79	☉	Operation mode selection	1	0	0	External/PU switchover mode	○	○	○
						1	Fixed to PU operation mode			
						2	Fixed to External operation mode			
						3	External/PU combined operation mode 1			
						4	External/PU combined operation mode 2			
						6	Switchover mode			
						7	External operation mode (PU operation interlock)			
	340		Communication startup mode selection	1	0	0	As set in Pr.79.	○	○	○
						1, 2	Started in the network operation mode. When the setting is "2", it will resume the pre-instantaneous power failure operation mode after an instantaneous power failure occurs.			
						10, 12	Started in the network operation mode. Operation mode can be changed between the PU operation mode and network operation mode from the operation panel. When the setting is "12", it will resume the pre-instantaneous power failure operation mode after an instantaneous power failure occurs.			
Simple magnetic flux vector control	80		Motor capacity (simple magnetic flux vector control)	0.01kW/0.1kW *13	9999	0.4 to 55/ 0 to 3600kW *13	To select the simple magnetic flux vector control, set the capacity of the motor used. *13 The setting depends on the inverter capacity (FR-F720-02330 (FR-F740-01160) or less/FR-F720-03160 (FR-F740-01800) or more)	○	○	○
						9999	V/F control is performed			
	90		Motor constant (R1)	0.001Ω/0.01mΩ* *14	9999	0 to 50Ω/ 0 to 400mΩ *14	Used to set the motor primary resistance value. (Normally setting is not necessary.) *14 The setting depends on the inverter capacity (FR-F720-02330 (FR-F740-01160) or less/FR-F720-03160 (FR-F740-01800) or more)	○	×	○
						9999	Use the Mitsubishi motor (SF-JR, SF-HRCA) constants			
Adjustable 5 points V/F	100		V/F1 (first frequency)	0.01Hz	9999	0 to 400Hz, 9999	Set each points (frequency, voltage) of V/F pattern. 9999: No V/F setting	○	○	○
	101		V/F1 (first frequency voltage)	0.1V	0V	0 to 1000V		○	○	○
	102		V/F2 (second frequency)	0.01Hz	9999	0 to 400Hz, 9999		○	○	○
	103		V/F2 (second frequency voltage)	0.1V	0V	0 to 1000V		○	○	○
	104		V/F3 (third frequency)	0.01Hz	9999	0 to 400Hz, 9999		○	○	○
	105		V/F3 (third frequency voltage)	0.1V	0V	0 to 1000V		○	○	○
	106		V/F4 (fourth frequency)	0.01Hz	9999	0 to 400Hz, 9999		○	○	○
	107		V/F4 (fourth frequency voltage)	0.1V	0V	0 to 1000V		○	○	○
	108		V/F5 (fifth frequency)	0.01Hz	9999	0 to 400Hz, 9999		○	○	○
	109		V/F5 (fifth frequency voltage)	0.1V	0V	0 to 1000V		○	○	○
	71		Refer to page 113.							

Function	Parameter		Name	Increments	Initial Value	Range	Description	Parameter copy	Parameter clear	All parameter clear
		Related parameters								
								O : enabled × : disabled		
Communication initial setting	117		PU communication station	1	0	0 to 31	Specify the inverter station number. Set the inverter station numbers when two or more inverters are connected to one personal computer.	○	○	○
	118		PU communication speed	1	192	48, 96, 192, 384	Set the communication speed. The setting value × 100 equals the communication speed. For example, the communication speed is 19200bps when the setting value is "192".	○	○	○
	119		PU communication stop bit length.	1	1	0	Stop bit length: 1bit data length: 8bit	○	○	○
						1	Stop bit length: 2bit data length: 8bit			
						10	Stop bit length: 1bit data length: 7bit			
						11	Stop bit length: 2bit data length: 7bit			
	120		PU communication parity check	1	2	0	Without parity check	○	○	○
						1	With odd parity check,			
						2	With even parity check			
	121		Number of PU communication retries	1	1	0 to 10	Set the permissible number of retries at occurrence of a data receive error. If the number of consecutive errors exceeds the permissible value, the inverter will come to an alarm stop.	○	○	○
						9999	If a communication error occurs, the inverter will not come to an alarm stop.			
	122		PU communication check time interval	0.1s	9999	0	No PU connector communication	○	○	○
						0.1 to 999.8s	Set the communication check time interval. If a no-communication state persists for longer than the permissible time, the inverter will come to an alarm stop.			
						9999	No communication check			
	123		PU communication waiting time setting	1	9999	0 to 150ms	Set the waiting time between data transmission to the inverter and response.	○	○	○
						9999	Set with communication data.			
	124		PU communication CR/LF presence/absence selection	1	1	0	Without CR/LF	○	○	○
						1	With CR			
						2	With CR/LF			
331		RS-485 communication station	1	0	0 to 31 (0 to 247)	Set the inverter station number. (same specifications as Pr.117) When "1" (Modbus-RTU protocol) is set in Pr.551, the setting range within parenthesis is applied.	○	○	○	
332		RS-485 communication speed	1	96	3, 6, 12, 24, 48, 96, 192, 384	Used to select the communication speed. (same specifications as Pr.118)	○	○	○	
333		RS-485 communication stop bit length	1	1	0, 1, 10, 11	Select stop bit length and data length. (same specifications as Pr.119)	○	○	○	
334		RS-485 communication parity check selection	1	2	0, 1, 2	Select the parity check specifications. (same specifications as Pr.120)	○	○	○	
335		RS-485 communication number of retries	1	1	0 to 10, 9999	Set the permissible number of retries at occurrence of a data receive error. (same specifications as Pr.121)	○	○	○	
336		RS-485 communication check time interval	0.1s	0s	0	RS-485 communication can be made, but the inverter will come to an alarm stop in the NET operation mode.	○	○	○	
					0.1 to 999.8s	Set the communication check time interval. (same specifications as Pr.122)				
					9999	No communication check				
337		RS-485 communication waiting time setting	1	9999	0 to 150ms, 9999	Set the waiting time between data transmission to the inverter and response. (same specifications as Pr.123)	○	○	○	
341		RS-485 communication CR/LF selection	1	1	0, 1, 2	Select presence/absence of CR/LF. (same specifications as Pr.124)	○	○	○	

Function	Parameter		Name	Increments	Initial Value	Range	Description	Parameter copy	Parameter clear	All parameter clear	
	Related parameters	O: enabled ×: disabled									
Communication initial setting		342		Communication EEPROM write selection	1	0	0	Parameter values written by communication are written to the EEPROM and RAM.	○	○	○
	1						Parameter values written by communication are written to the RAM.				
	343		Communication error count	1	0	(read only)	Display the number of communication errors during Modbus-RTU communication. Read only. Displayed only when Modbus-RTU protocol is selected.	×	×	×	
549		Protocol selection	1	1	0	Mitsubishi inverter (computer link) protocol	After setting change, reset (switch power off, then on) the inverter. The setting change is reflected after a reset.	○	○	○	
					1	Modbus-RTU protocol					
Change of analog input frequency, adjustment of voltage, current input and frequency (calibration)	125	◎	Terminal 2 frequency setting gain frequency	0.01Hz	60Hz	0 to 400Hz	Set the frequency of terminal 2 input gain (maximum).	○	×	○	
	126	◎	Terminal 4 frequency setting gain frequency	0.01Hz	60Hz	0 to 400Hz	Set the frequency of terminal 4 input gain (maximum).	○	×	○	
	241		Analog input display unit switchover	1	0	0	Displayed in %	Select the unit for analog input display.	○	○	○
						1	Displayed in V/mA				
	C2 (902)		Terminal 2 frequency setting bias frequency	0.01Hz	0Hz	0 to 400Hz	Set the frequency on the bias side of terminal 2 input.	○	×	○	
	C3 (902)		Terminal 2 frequency setting bias	0.1%	0%	0 to 300%	Set the converted % of the bias side voltage (current) of terminal 2 input.	○	×	○	
	C4 (903)		Terminal 2 frequency setting gain	0.1%	100%	0 to 300%	Set the converted % of the gain side voltage of terminal 2 input.	○	×	○	
	C5 (904)		Terminal 4 frequency setting bias frequency	0.01Hz	0Hz	0 to 400Hz	Set the frequency on the bias side of terminal 4 input.	○	×	○	
C6 (904)		Terminal 4 frequency setting bias	0.1%	20%	0 to 300%	Set the converted % of the bias side current (voltage) of terminal 4 input.	○	×	○		
C7 (905)		Terminal 4 frequency setting gain	0.1%	100%	0 to 300%	Set the converted % of the gain side current (voltage) of terminal 4 input.	○	×	○		

The parameter number in parentheses is the one for use with the parameter unit (FR-PU04).

Function	Parameter	Name	Increments	Initial Value	Range	Description	Parameter copy	Parameter clear	All parameter clear	
							O : enabled × : disabled			
PID control	127	PID control automatic switchover frequency	0.01Hz	9999	0 to 400Hz	Set the frequency at which the control is automatically changed to PID control.	○	○	○	
					9999	Without PID automatic switchover function				
	128	PID action selection	1	10	10	PID reverse action	Deviation value signal (terminal 1)	○	○	○
					11	PID forward action				
					20	PID reverse action	Measured value input (terminal 4) Set value (terminal 2 or Pr. 133)			
					21	PID forward action				
					50	PID reverse action	Deviation value signal input (LONWORKS, CC-Link communication)			
					51	PID forward action				
					60	PID reverse action				
	61	PID forward action								
	129	PID proportional band	0.1%	100%	0.1 to 1000%	If the proportional band is narrow (parameter setting is small), the manipulated variable varies greatly with a slight change of the measured value. Hence, as the proportional band narrows, the response sensitivity (gain) improves but the stability deteriorates, e.g. hunting occurs. Gain $K = 1/\text{proportional band}$	○	○	○	
					9999	No proportional control				
	130	PID integral time	0.1s	1s	0.1 to 3600s	Time required for only the integral (I) action to provide the same manipulated variable as that for the proportional (P) action. As the integral time decreases, the set point is reached earlier but hunting occurs more easily.	○	○	○	
					9999	No integral control.				
	131	PID upper limit	0.1%	9999	0 to 100%	Set the upper limit value. If the feedback value exceeds the setting, the FUP signal is output. The maximum input (20mA/5V/10V) of the measured value (terminal 4) is equivalent to 100%.	○	○	○	
9999					No function					
132	PID lower limit	0.1%	9999	0 to 100%	Set the lower limit value. If the measured value falls below the setting range, the FDN signal is output. The maximum input (20mA/5V/10V) of the measured value (terminal 4) is equivalent to 100%.	○	○	○		
				9999	No function					
133	PID action set point	0.01%	9999	0 to 100%	Used to set the set point for PID control.	○	○	○		
				9999	Terminal 2 input voltage is the set point.					

Function	Parameter		Name	Increments	Initial Value	Range	Description	Parameter copy	Parameter clear	All parameter clear
		Related parameters								
								O : enabled × : disabled		
PID control	134		PID differential time	0.01s	9999	0.01 to 10.00s	Time required for only the differential (D) action to provide the same manipulated variable as that for the proportional (P) action. As the differential time increases, greater response is made to a deviation change.	○	○	○
						9999	No differential control.			
	575		Output interruption detection time	0.1s	1s	0 to 3600s	If the output frequency after PID operation remains lower than the <i>Pr. 576</i> setting for longer than the time set in <i>Pr. 575</i> , the inverter stops operation.	○	○	○
						9999	Without output interruption function			
	576		Output interruption detection level	0.01Hz	0Hz	0 to 400Hz	Set the frequency at which the output interruption processing is performed.	○	○	○
577		Output interruption release level	0.1%	1000%	900 to 1100%	Set the level (<i>Pr.577</i> minus 1000%) to release the PID output interruption function.	○	○	○	
Switch between the inverter operation and commercial power-supply operation to use	135		Commercial power-supply switchover sequence output terminal selection	1	0	0	With commercial power-supply switchover sequence	○	○	○
						1	Without commercial power-supply switchover sequence			
	136		MC switchover interlock time	0.1s	1s	0 to 100s	Set the operation interlock time of MC2 and MC3.	○	○	○
	137		Waiting time at a start	0.1s	0.5s	0 to 100s	Set the time slightly longer (0.3 to 0.5s or so) than the time from when the ON signal enters MC3 until it actually turns on.	○	○	○
	138		Commercial power-supply operation switchover selection at an alarm	1	0	0	Inverter output is stopped (motor coast) at inverter fault.	○	○	○
						1	Operation is automatically switched to the commercial power-supply operation at inverter fault (Not switched when an external thermal error occurs)			
	139		Automatic switchover frequency between inverter and commercial power-supply operation	0.01Hz	9999	0 to 60Hz	Set the frequency to switch the inverter operation to the commercial power-supply operation.	○	○	○
9999						Without automatic switchover				
159		Automatic switchover ON range between commercial power-supply and inverter operation	0.01Hz	9999	0 to 10Hz	Valid during automatic switchover operation (<i>Pr.139</i> ≠ 9999) When the frequency command decreases below (<i>Pr.139</i> to <i>Pr.159</i>) after operation is switched from inverter operation to commercial power-supply operation, the inverter automatically switches operation to the inverter operation and operates at the frequency of frequency command. When the inverter start command (STF/STR) is turned off, operation is switched to the inverter operation also.	○	○	○	
					9999	Valid during automatic switchover operation (<i>Pr.139</i> ≠ 9999) When the inverter start command (STF/STR) is turned off after operation is switched from the inverter operation to commercial power-supply inverter operation, operation is switched to the inverter operation and the motor decelerates to stop.				
—	140 to 143	Refer to <i>Pr.29</i> .								
	144	Refer to <i>Pr.37</i> .								

Function	Parameter	Name	Increments	Initial Value	Range	Description	Param eter copy	Param eter clear	All param eter clear
							O : enabled × : disabled		
Parameter unit language switchover	145	PU display language selection	1	1	0	Japanese	O	×	×
					1	English			
					2	Germany			
					3	French			
					4	Spanish			
					5	Italian			
					6	Swedish			
7	Finnish								
—	148, 149	Refer to <i>Pr.22 and Pr.23</i> .							
Detection of output current (Y12 signal) Detection of zero current (Y13 signal)	150	Output current detection level	0.1%	110%	0 to 120%	Set the output current detection level. 100% is the rated inverter current.	O	O	O
	151	Output current detection signal delay time	0.1s	0s	0 to 10s	Set the output current detection period. Set the time from when the output current has risen above the setting until the output current detection signal (Y12) is output.	O	O	O
	152	Zero current detection level	0.1%	5%	0 to 150%	Set the zero current detection level. Suppose that the rated inverter current is 100%.	O	O	O
	153	Zero current detection time	0.01s	0.5s	0 to 1s	Set this parameter to define the period from when the output current drops below the <i>Pr.152</i> value until the zero current detection signal (Y13) is output.	O	O	O
		166	Output current detection signal retention time	0.1s	0.1s	0 to 10s 9999	Set the retention time when the Y12 signal is on. The Y12 signal on status is retained. The signal is turned off at the next start.	O	O
	167	Output current detection operation selection	1	0	0	Operation continues when the Y12 signal is on	O	O	O
1					The inverter is brought to an alarm stop when the Y12 signal is on. (E.CDO)				
—	154	Refer to <i>Pr.22 and Pr.23</i> .							
Selection of action conditions of the second function	155	RT signal reflection time selection	1	0	0	This function is immediately made valid with on/off of the RT signal.	O	O	O
					10	The on/off of the RT signal is valid only during a stop and constant speed operation. (Invalid during acceleration/ deceleration)			
—	156, 157	Refer to <i>Pr.22 and Pr.23</i> .							
	158	Refer to <i>Pr.54 to Pr.56</i> .							
	159	Refer to <i>Pr.135 to Pr.139</i> .							
Display of applied parameters and user group function	160	⊙ User group read selection	1	0	9999	Only the simple mode parameters can be displayed.	O	O	O
					1	Only the parameters registered in the user group can be displayed.			
					0	Simple mode and extended mode parameters can be displayed.			
	172	User group registered display/ batch clear	1	0	(0 to 16)	Displays the number of cases registered as a user group (reading only).	O	×	×
					9999	Batch clear the user group registration			
173	User group registration	1	9999	0 to 999, 9999	Set the parameter numbers to be registered to the user group. Read value is always "9999".	O	×	×	
174	User group clear	1	9999	0 to 999, 9999	Set the parameter numbers to be cleared from the user group. Read value is always "9999".	O	×	×	

Function	Parameter		Increments	Initial Value	Range	Description	Parameter copy	Parameter clear	All parameter clear	
		Related parameters								
							O: enabled x: disabled			
Operation selection of the operation panel	161	Frequency setting/ key lock operation selection	1	0	0	Setting dial frequency setting mode	key lock mode invalid	O	x	O
					1	Setting dial potentiometer mode				
					10	Setting dial frequency setting mode	Key lock mode valid			
					11	Setting dial potentiometer mode				
—	162 to 165	Refer to <i>Pr.57 and Pr.58.</i>								
	166, 167	Refer to <i>Pr.150 to Pr.153.</i>								
	168, 169	Parameter for manufacturer setting. Do not set.								
	170, 171	Refer to <i>Pr.52.</i>								
	172 to 174	Refer to <i>Pr.160.</i>								
Function assignment of input terminal	178	STF terminal function selection	1	60	0 to 8, 10 to 12, 14, 16, 24, 25, 60, 62, 64 to 67, 9999	0: Low-speed operation command 1: Middle-speed operation command 2: High-speed operation command 3: Second function selection 4: Terminal 4 input selection 5: Jog operation selection 6: Selection of automatic restart after instantaneous power failure 7: External thermal relay input 8: Fifteen speed selection 10: Inverter operation enable signal (FR-HC, MT-HC, FR-CV connection) 11: FR-HC, MT-HC connection, instantaneous power failure detection 12: PU operation external interlock 13: External DC injection brake start 14: PID control valid terminal 16: PU-external operation switchover 24: Output stop 25: Start self-holding selection 60: Forward rotation command (assigned to STF terminal (<i>Pr.178</i>) only) 61: Reverse rotation command (assigned to STR terminal (<i>Pr.179</i>) only) 62: Inverter reset 63: PTC thermistor input (assigned to AU terminal (<i>Pr.184</i>) only) 64: PID forward/reverse action switchover 65: PU-NET operation switchover 66: External-NET operation switchover 67: Command source switchover 9999: No function	O	x	O	
	179	STR terminal function selection	1	61	0 to 8, 10 to 12, 14, 16, 24, 25, 61, 62, 64 to 67, 9999		O	x	O	
	180	RL terminal function selection	1	0	0 to 8, 10 to 14, 16, 24, 25, 62, 64 to 67, 9999		O	x	O	
	181	RM terminal function selection	1	1			O	x	O	
	182	RH terminal function selection	1	2			O	x	O	
	183	RT terminal function selection	1	3			O	x	O	
	184	AU terminal function selection	1	4			O	x	O	
	185	JOG terminal function selection	1	5	0 to 8, 10 to 14, 16, 24, 25, 62, 64 to 67, 9999		O	x	O	
	186	CS terminal function selection	1	6			O	x	O	
	187	MRS terminal function selection	1	24			O	x	O	
	188	STOP terminal function selection	1	25			O	x	O	
189	RES terminal function selection	1	62	O		x	O			

Function	Parameter		Increments	Initial Value	Range	Description	Parameter copy	Parameter clear	All parameter clear
	Related parameters	Name					O: enabled x: disabled		
Terminal assignment of output terminal			190	RUN terminal function selection	1	0	0 to 5, 7, 8, 10 to 19, 25, 26, 45 to 47, 64, 70 to 78, 90 to 96, 98, 99, 100 to 105, 107, 108, 110 to 116, 125, 126, 145 to 147, 164, 170, 190 to 196, 198, 199, 9999	0, 100: Inverter running 1, 101: Up to frequency 2, 102: Instantaneous power failure/undervoltage 3, 103: Overload alarm 4, 104: Output frequency detection 5, 105: Second output frequency detection 7, 107: Regenerative brake prealarm (Only for the FR-F720-03160 (FR-F740-01800) or more) 8, 108: Electronic thermal relay function prealarm 10, 110: PU operation mode 11, 111: Inverter operation ready 12, 112: Output current detection 13, 113: Zero current detection 14, 114: PID lower limit 15, 115: PID upper limit 16, 116: PID forward/reverse rotation output	○
	191	SU terminal function selection	1	1	17, —: Commercial power-supply switchover MC1 18, —: Commercial power-supply switchover MC2 19, —: Commercial power-supply switchover MC3	○		×	○
	192	IPF terminal function selection	1	2	25, 125: Fan fault output 26, 126: Heatsink overheat pre-alarm 45, 145: During inverter running and start command is on 46, 146: During deceleration at occurrence of power failure (retained until release)	○		×	○
	193	OL terminal function selection	1	3	47, 147: During PID control activated 64, 164: During retry 70, 170: PID output interruption 71: Commercial-power supply side motor 1 connection RO1 72: Commercial-power supply side motor 2 connection RO2 73: Commercial-power supply side motor 3 connection RO3 74: Commercial-power supply side motor 4 connection RO4	○		×	○
	194	FU terminal function selection	1	4	75: Inverter side motor 1 connection RIO1 76: Inverter side motor 2 connection RIO2 77: Inverter side motor 3 connection RIO3 78: Inverter side motor 4 connection RIO4	○		×	○
	195	ABC1 terminal function selection	1	99	90, 190: Life alarm 91, 191: Alarm output 3 (power-off signal) 92, 192: Energy saving average value updated timing 93, 193: Current average monitor 94, 194: Alarm output 2 95, 195: Maintenance timer alarm 96, 196: Remote output 98, 198: Minor fault output 99, 199: Alarm output 9999: No function	○	×	○	
	196	ABC2 terminal function selection	1	9999	0 to 99: Positive logic, 100 to 199: Negative logic	○	×	○	

Function	Parameter		Name	Increments	Initial Value	Range	Description	Param eter copy	Param eter clear	All param eter clear
	Related parameters							O : enabled × : disabled		
—	232 to 239		Refer to Pr.4 to Pr.6.							
	240		Refer to Pr.72.							
	241		Refer to Pr.125 and Pr.126.							
	242, 243		Refer to Pr.73.							
Increase cooling fan life	244	Cooling fan operation selection	1	1	0	Operates at power on Cooling fan on/off control invalid (The cooling fan is always on at power on)	O	O	O	
					1					Cooling fan on/off control valid
Slip compensation	245	Rated slip	0.01%	9999	0 to 50%	Used to set the rated motor slip.	O	O	O	
					9999					No slip compensation
	246	Slip compensation time constant	0.01s	0.5s	0.01 to 10s	Used to set the response time of slip compensation. When the value is made smaller, response will be faster. However, as load inertia is greater, a regenerative overvoltage (E.OV□) error is more liable to occur.	O	O	O	
										247
9999	Slip compensation is made in the constant output range.									
Selection of motor stopping method	250	Stop selection	0.1s	9999	0 to 100s	The motor is coasted to a stop when the preset time elapses after the start signal is turned off. When 1000s to 1100s is set (Pr. 250 setting-1000)s later, the motor coasts to stop.	O	O	O	
					1000 to 1100s					STF signal: Forward rotation start STR signal: Reverse rotation start
					8888	When the start signal is turned off, the motor decelerates to stop.	STF signal: Start signal STR signal: Forward/reverse signal			
					9999		STF signal: Start signal STR signal: Forward/reverse signal			
Input/output phase failure protection selection	251	Output phase failure protection selection	1	1	0	Without output phase failure protection	O	O	O	
					1					With output phase failure protection
	872	Input phase failure protection selection	1	0	0	Without input phase failure protection	O	O	O	
					1					With input phase failure protection
—	252, 253		Refer to Pr.73.							

Function	Parameter Related parameters	Name	Increments	Initial Value	Range	Description	Param eter copy	Param eter clear	All param eter clear
							O : enabled x : disabled		
Display of the life of the inverter parts	255	Life alarm status display	1	0	(0 to 15)	Display whether the control circuit capacitor, main circuit capacitor, cooling fan, and each parts of the inrush current limit circuit has reached the life alarm output level or not.	x	x	x
	256	Inrush current limit circuit life display	1%	100%	(0 to 100%)	Display the deterioration degree of the inrush current limit circuit. Reading only	x	x	x
	257	Control circuit capacitor life display	1%	100%	(0 to 100%)	Display the deterioration degree of the control circuit capacitor. Reading only	x	x	x
	258	Main circuit capacitor life display	1%	100%	(0 to 100%)	Display the deterioration degree of the main circuit capacitor. Reading only The value measured by Pr. 259 is displayed.	x	x	x
	259	Main circuit capacitor life measuring	1	0	0, 1	Start measuring the main circuit capacitor life. Switch the power supply on again and check the Pr. 259 setting. Measurement is complete if the setting is "3". Set the deterioration degree in Pr.258.	O	O	O
—	260	Refer to Pr.72.							
Decelerate the motor to a stop at instantaneous power failure	261	Power failure stop selection	1	0	0	Coasting to stop When undervoltage or power failure occurs, the inverter output is shut off.	O	O	O
					1	When undervoltage or a power failure occurs, the inverter can be decelerated to a stop.			
					2	When undervoltage or a power failure occurs, the inverter can be decelerated to a stop. If power is restored during a power failure, the inverter accelerates again.			
	262	Subtracted frequency at deceleration start	0.01Hz	3Hz	0 to 20Hz	Normally operation can be performed with the initial value unchanged. But adjust the frequency according to the magnitude of the load specifications (moment of inertia, torque).	O	O	O
	263	Subtraction starting frequency	0.01Hz	60Hz	0 to 120Hz	When output frequency \geq Pr.263 Decelerate from the speed obtained from output frequency minus Pr.262. When output frequency $<$ Pr.263 Decelerate from output frequency	O	O	O
					9999	Decelerate from the speed obtained from output frequency minus Pr.262.			
	264	Power-failure deceleration time 1	0.1/ 0.01s	5s	0 to 3600/ 360s	Set a deceleration slope down to the frequency set in Pr.266.	O	O	O
265	Power-failure deceleration time 2	0.1/ 0.01s	9999	0 to 3600/ 360s	Set a deceleration slope below the frequency set in Pr.266.	O	O	O	
				9999	Same slope as in Pr.264				
266	Power failure deceleration time switchover frequency	0.01Hz	60Hz	0 to 400Hz	Set the frequency at which the deceleration slope is switched from the Pr.264 setting to the Pr.265 setting.	O	O	O	
—	267	Refer to Pr.73.							
	268	Refer to Pr.52.							
	269	Parameter for manufacturer setting. Do not set.							
	331 to 337	Refer to Pr.117 to Pr.124.							

Function	Parameter	Name	Increments	Initial Value	Range	Description	Parameter copy	Parameter clear	All parameter clear
							O : enabled x : disabled		
Operation command source and speed command source during communication operation	338	Communication operation command source	1	0	0	Operation command source communication	○	○	○
					1	Operation command source external			
	339	Communication speed command source	1	0	0	Speed command source communication	○	○	○
					1	Speed command source external (Frequency setting from communication is invalid, terminal 2 and 1 setting from external is valid)			
					2	Speed command source external (Frequency setting from communication is valid, terminal 2 and 1 setting from external is invalid)			
	550	NET mode operation command source selection	1	9999	0	Communication option valid	○	○	○
					1	Inverter RS-485 terminal valid			
	551	PU mode operation command source selection	1	2	1	Select the RS-485 terminals as the PU operation mode control source.	○	○	○
					2	Select the PU connector as the PU operation mode control source.			
	—	340	Refer to <i>Pr.79</i> .						
341 to 343		Refer to <i>Pr.117 to Pr.124</i> .							
Remote output function (REM signal)	495	Remote output selection	1	0	0	Remote output data clear at powering off	○	○	○
					1	Remote output data retention even at powering off			
	496	Remote output data 1	1	0	0 to 4095	Output terminal can be switched on and off.	x	x	x
497	Remote output data 2	1	0	0 to 4095	x		x	x	
To determine the maintenance time of parts.	503	Maintenance timer	1	0	0 (1 to 9998)	Display the cumulative energization time of the inverter in 100h increments. Reading only Writing the setting of "0" clears the cumulative energization time.	x	x	x
	504	Maintenance timer alarm output set time	1	9999	0 to 9998	Set the time taken until when the maintenance timer alarm output signal (Y95) is output.	○	x	○
9999					No function				
—	549	Refer to <i>Pr.117 to Pr.124</i> .							
	550, 551	Refer to <i>Pr.338 and Pr.339</i> .							
Current average value monitor signal	555	Current average time	0.1s	1s	0.1 to 1.0s	Set the time taken to average the current during start bit output (1s).	○	○	○
	556	Data output mask time	0.1s	0s	0.0 to 20.0s	Set the time for not obtaining (mask) transient state data.	○	○	○
	557	Current average value monitor signal output reference current	0.01/0.1A ^{*15}	Rated inverter current	0 to 500/0 to 3600A ^{*15}	Set the reference (100%) for outputting the signal of the current average value. ^{*15} Setting increments and setting range differ according to the inverter capacity. (FR-F720-02330 (FR-F740-01160) or less/FR-F720-03160 (FR-F740-01800) or more)	○	○	○
—	563, 564	Refer to <i>Pr.52</i> .							
Multiple rating selection	570	Multiple rating setting	1	0	0	SLD: Ambient temperature 40°C, overload 110% 60s, 120% 3s	○	x	x
					1	LD: Ambient temperature 50°C, overload 120% 60s, 150% 3s			
—	571	Refer to <i>Pr.13</i> .							
	573	Refer to <i>Pr.73</i> .							
	575 to 577	Refer to <i>Pr.127 to Pr.134</i> .							

Function	Parameter	Name	Increments	Initial Value	Range	Description	Parameter copy	Parameter clear	All parameter clear
							○ : enabled × : disabled		
Pump function	578	Auxiliary motor operation selection	1	0	0	No auxiliary motor operation	○	○	○
					1 to 3	Set the number of auxiliary motors to be run			
	579	Motor connection function selection	1	0	0	Basic system	○	○	○
					1	Alternative system			
					2	Direct system			
					3	Alternative-direct system			
	580	MC switching interlock time	0.1s	1s	0 to 100s	You can set the MC switching interlock time when Pr. 579 = "2, 3".	○	○	○
	581	Start waiting time	0.1s	1s	0 to 100s	You can set the time from MC switch-over to a start when Pr. 579 = "2, 3". Set this time a little longer than the MC switching time.	○	○	○
	582	Auxiliary motor connection-time deceleration time	0.1s	1s	0 to 3600s	You can set the deceleration time for decreasing the output frequency of the inverter if a motor connection occurs under advanced PID control.	○	○	○
					9999	The output frequency is not forcibly changed.			
	583	Auxiliary motor disconnection-time acceleration time	0.1s	1s	0 to 3600s	You can set the acceleration time for increasing the output frequency of the inverter if a motor disconnection occurs under advanced PID control.	○	○	○
					9999	The output frequency is not forcibly changed.			
	584	Auxiliary motor 1 starting frequency	0.01Hz	60Hz	0 to 400Hz	Set the frequency to connect an auxiliary motor.	○	○	○
	585	Auxiliary motor 2 starting frequency	0.01Hz	60Hz	0 to 400Hz		○	○	○
	586	Auxiliary motor 3 starting frequency	0.01Hz	60Hz	0 to 400Hz		○	○	○
587	Auxiliary motor 1 stopping frequency	0.01Hz	0Hz	0 to 400Hz	Set the frequency to open an auxiliary motor.	○	○	○	
588	Auxiliary motor 2 stopping frequency	0.01Hz	0Hz	0 to 400Hz		○	○	○	
589	Auxiliary motor 3 stopping frequency	0.01Hz	0Hz	0 to 400Hz		○	○	○	
590	Auxiliary motor start detection time	0.1s	5s	0 to 3600s	You can set the delay time until the auxiliary motor is started.	○	○	○	
591	Auxiliary motor stop detection time	0.1s	5s	0 to 3600s	You can set the delay time until the auxiliary motor is stopped.	○	○	○	
—	611	Refer to Pr.57 and Pr.58.							
	867, 869	Refer to Pr.54 to Pr.56.							
	872	Refer to Pr.251.							

Function	Parameter		Name	Increments	Initial Value	Range	Description	Parameter copy	Parameter clear	All parameter clear
	Related parameters	O: enabled x: disabled								
Regeneration avoidance function		882		Regeneration avoidance operation selection	1	0	0	Regeneration avoidance function invalid	○	○
	1						Regeneration avoidance function valid			
	883		Regeneration avoidance operation level	0.1V	DC380V / 760V*	300 to 800V	Set the bus voltage level at which regeneration avoidance operates. When the bus voltage level is set to low, overvoltage error will be less apt to occur. However, the actual deceleration time increases. * The initial value differs according to the voltage level. (200V class / 400V class)	○	○	○
	884		Regeneration avoidance at deceleration detection sensitivity	1	0	0 to 5	Set sensitivity to detect the bus voltage change. 1 (Low) → 5 (High)	○	○	○
	885		Regeneration avoidance compensation frequency limit value	0.01Hz	6Hz	0 to 10Hz	Set the limit value of frequency which rises at activation of regeneration avoidance function.	○	○	○
9999						Frequency limit invalid				
886		Regeneration avoidance voltage gain	0.1%	100%	0 to 200%	Adjust responsiveness at activation of regeneration avoidance. A larger setting will improve responsiveness to the bus voltage change. However, the output frequency could become unstable.	○	○	○	
Free parameter	888		Free parameter 1	1	9999	0 to 9999	Parameters you can use for your own purposes.	○	x	x
	889		Free parameter 2	1	9999	0 to 9999	Used for maintenance, management, etc. by setting a unique number to each inverter when multiple inverters are used.	○	x	x

Function	Parameter	Name	Increments	Initial Value	Range	Description	Param eter copy	Param eter clear	All param eter clear
							O : enabled × : disabled		
Energy saving monitor	891	Refer to <i>Pr.52</i> .							
	892	Load factor	0.1%	100%	30 to 150%	Set the load factor for commercial power-supply operation. This value is used to calculate the power consumption estimated value during commercial power supply operation.	O	O	O
	893	Energy saving monitor reference (motor capacity)	0.01/ 0.1kW *16	LD/SLD value of Applied moter Capacity	0.1 to 55/ 0 to 3600kW *16	Set the motor capacity (pump capacity). Set when calculating power saving rate and average power saving rate value. *16 The setting depends on the inverter capacity (FR-F720-02330 (FR-F740-01160) or less/FR-F720-03160 (FR-F740-01800) or more)	O	O	O
	894	Control selection during commercial power-supply operation	1	0	0	Discharge damper control (fan)	O	O	O
					1	Inlet damper control (fan)			
					2	Valve control (pump)			
					3	Commercial power-supply drive (fixed value)			
	895	Power saving rate reference value	1	9999	0	Consider the value during commercial power-supply operation as 100%	O	O	O
					1	Consider the <i>Pr.893</i> setting as 100%.			
					9999	No function			
	896	Power unit cost	0.01	9999	0 to 500	Set the power unit cost. Display the power saving rate on the energy saving monitor	O	O	O
					9999	No function			
	897	Power saving monitor average time	1	9999	0	Average for 30 minutes	O	O	O
1 to 1000h					Average for the set time				
9999					No function				
898	Power saving cumulative monitor clear	1	9999	0	Cumulative monitor value clear	O	O	O	
				1	Cumulative monitor value hold				
				10	Cumulative monitor continue (communication data upper limit 9999)				
				9999	Cumulative monitor continue (communication data upper limit 65535)				
899	Operation time rate (estimated value)	0.1%	9999	0 to 100%	Use for calculation of annual power saving amount. Set the annual operation ratio (consider 365 days × 24hr as 100%).	O	O	O	
				9999	No function				
Adjustment of terminal CA and AM (calibration)	C0 (900)	CA terminal calibration	—	—	—	Calibrate the scale of the meter connected to terminal CA.	O	×	O
	C1 (901)	AM terminal calibration	—	—	—	Calibrate the scale of the analog meter connected to terminal AM.	O	×	O
—	C2 (902)	Terminal 2 frequency setting bias frequency	Refer to <i>Pr.125 and Pr.126</i> .						
	C3 (902)	Terminal 2 frequency setting bias							
	C4 (903)	Terminal 2 frequency setting gain							
	C5 (904)	Terminal 4 frequency setting bias frequency							
	C6 (904)	Terminal 4 frequency setting bias							
	C7 (905)	Terminal 4 frequency setting gain							

Function	Parameter Related parameters	Name	Increments	Initial Value	Range	Description	Parameter copy	Parameter clear	All parameter clear
							O : enabled × : disabled		
Analog output current calibration	C8 (930)	Current output bias signal	0.1%	0%	0 to 100%	Set the output signal value at the minimum analog current output.	O	O	O
	C9 (930)	Current output bias current	0.1%	0%	0 to 100%	Set the minimum current value at the minimum analog current output.	O	O	O
	C10 (931)	Current output gain signal	0.1%	100%	0 to 100%	Set the output signal value at the maximum analog current output.	O	O	O
	C11 (931)	Current output gain current	0.1%	100%	0 to 100%	Set the maximum current value at the maximum analog current output.	O	O	O
—	989	Parameter copy alarm release	1	10/100 ^{*17}	10, 100	Parameters for alarm release at parameter copy ^{*17} The setting depends on the inverter capacity (FR-F720-02330 (FR-F740-01160) or less/FR-F720-03160 (FR-F740-01800) or more)	O	×	O
Buzzer control of the operation panel	990	PU buzzer control	1	1	0	Without buzzer	O	O	O
					1	With buzzer			
Contrast adjustment of the parameter unit	991	PU contrast adjustment	1	58	0 to 63	Contrast adjustment of the LCD of the parameter unit (FR-PU04) can be performed. 0 (Light) → 63 (Dark)	O	O	O
Parameter clear, parameter copy	Pr.CL	Parameter clear	1	0	0, 1	Setting "1" returns all parameters except calibration parameters to the initial values.			
	ALLC	All parameter clear	1	0	0, 1	Setting "1" returns all parameters to the initial values.			
	Er.CL	Alarm history clear	1	0	0, 1	Setting "1" will clear eight past alarms.			
	PCPY	Parameter copy	1	0	0	Cancel			
					1	Read the source parameters to the operation panel.			
2					Write the parameters copied to the operation panel to the destination inverter.				
3					Verify parameters in the inverter and operation panel.				

Appendix 3 For customers who have replaced the older model with this inverter

Appendix 3-1 Replacement of the FR-F500 series

(1) Instructions for installation

- 1) Removal procedure of the front cover was changed. (with screws) Please note. (Refer to page 5.)
- 2) Removal procedure of the operation panel was changed. (with screws) Please note. (Refer to page 5.)
- 3) Plug-in options of the F500 series are not compatible
- 4) Operation panel (FR-DU04) can not be used.
- 5) Setup software (FR-SW0-SETUP) can not be used.

(2) Wiring instructions

- 1) The control circuit terminal block can be used for the FR-F700 series without removing wiring.

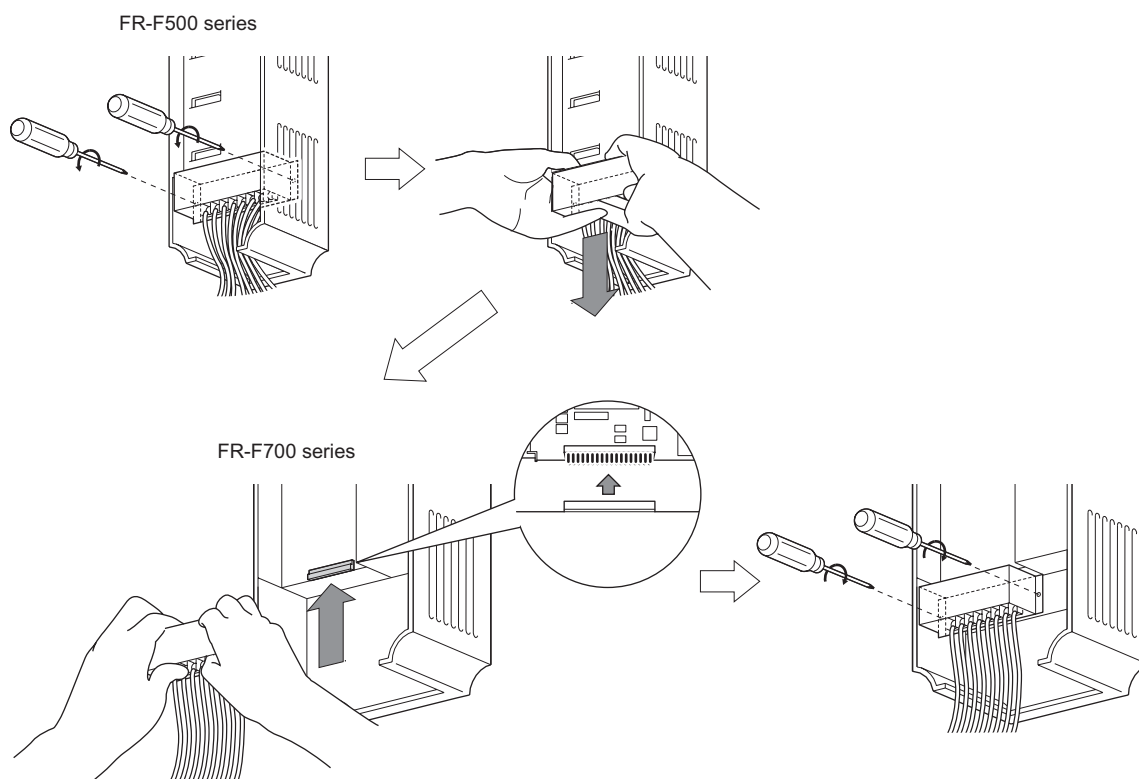

(Note that the relay output 2 (A2, B2, C2) specific for the FR-F700 series can not be used with the FR-F500 series terminals.)

(3) Instructions for continuous use of the FR-PU04 (parameter unit)

- 1) For the FR-F700 series, many functions (parameters) have been added. When setting these parameters, the parameter name and setting range are not displayed. Parameter list, change list, initial value list, initial value list 2 and parameter clear of the HELP function can not be used.
- 2) For the FR-F700 series, many protective functions have been added. These functions activate, but alarms are not displayed. In addition, these are not included in the alarm history and not displayed. Alarm history clear and trouble shooting can not be used for additional functions.
- 3) User initial value setting can not be used.
- 4) User registration/clear (user group 2) can not be used.
- 5) Parameter copy/verification function can not be used.

(4) Main differences and compatibilities with the FR-F500(L) series

Item	FREQROL-F500(L)	FR-F700
Changed/cleared functions	Simple mode parameters 61	Simple mode parameters 15
	Pr. 0 Torque boost initial value 11K to 55K: 2%	Pr. 0 Torque boost initial value initial value 00250 to 00770: 2%, 00930, 01160: 1.5% (When the torque boost value of the FR-F500 series used was the initial value, it is not necessary to change the torque boost value from the initial value when replacing with the FR-F700 series.)
	User group 1 (16), user group 2 (16) (Pr. 160, Pr. 173 to Pr. 175)	User group (16) only Setting methods were partially changed (Pr. 160, Pr. 172 to Pr. 173)
	User initial value setting (Pr. 199)	"User initial value setting" (Pr. 199) was cleared Substitutable with the copy function of the operation panel (FR-DU07)
	Intelligent optimum acceleration/deceleration (Pr. 60 setting "3" and Pr. 61 to Pr. 63)	Function was cleared For deceleration time, overvoltage alarm can be avoided with regeneration avoidance function (Pr. 882 to Pr. 885).
	Automatic torque boost (Pr. 38, Pr. 39)	Automatic torque boost was cleared because of addition of "Simple magnetic flux vector" (Pr. 80)
	Advanced PID (pump function) Pr.500 to Pr.516	Parameter number change Pr.575 to Pr.591
Terminal block	Removable terminal block Priority compatibility (Terminal block of the F500 can be mounted)	
PU	FR-DU07 FR-DU04 unavailable (Partly restricted when the FR-PU04 is used. Refer to page 130.)	
Plug-in option	Dedicated plug-in option (not compatible)	
	Computer link, relay output option FR-A5NR	Built into the inverter (RS-485 terminal, relay output 2 points)
	Three boards can be mounted	One board can be mounted
Installation size	FR-F720-00046, 00105, 00167, 00340, 00770, 00930, 01250, 01870, FR-F740-00023 to 00083, 00170, 00470, 00770 to 01160 are compatible in mounting dimensions For other capacities, an optional intercompatibility attachment (FR-AAT) is necessary.	

Appendix 3-2 Replacement of the FR-A100 <EXCELENT> series

Instructions for installation

- When using the installation holes of the FR-A100(E) series, FR-A5AT (intercompatibility attachment) is necessary.

Appendix 4 Instructions for UL and cUL

(Conforming standard UL 508C, CSA C22.2 No.14)

(1) Installation

This inverter is UL-listed as a product for use in an enclosure.

Design an enclosure so that the inverter ambient temperature, humidity and atmosphere satisfy the specifications.

(Refer to page 94.)

Wiring protection

For installation in the United States, branch circuit protection must be provided in accordance with the National Electrical Code and any applicable provincial codes.

For installation in Canada, branch circuit protection must be provided in accordance with the Canada Electrical Code and any applicable provincial codes.

Use the Class RK5, Class T or L type fuses certified by UL and cUL.

FR-F720-□□□□□-NA		00046	00077	00105	00167	00250	00340	00490	00630	00770	00930	01250	01540	01870	02330
Rated voltage(V)		240V or more													
Rated current (A)	Without power factor improving reactor	15	20	30	40	60	80	150	175	200	225	300	350	400	500
	With power factor improving reactor	15	20	20	30	50	70	125	150	200	200	250	300	350	400

FR-F720-□□□□□-NA		03160	03800	04750
Rated voltage(V)		240V or more		
Rated current (A)	Without power factor improving reactor	—	—	—
	With power factor improving reactor	500	600	700

FR-F740-□□□□□-NA		00023	00038	00052	00083	00126	00170	00250	00310	00380	00470	00620	00770	00930	01160
Rated voltage(V)		480V or more													
Rated current (A)	Without power factor improving reactor	6	10	15	20	30	40	70	80	90	110	150	175	200	250
	With power factor improving reactor	6	10	10	15	25	35	60	70	90	100	125	150	175	200

FR-F740-□□□□□-NA		01800	02160	02600	03250	03610	04320	04810	05470	06100	06830	07700	08660	09620	10940	12120
Rated voltage(V)		500V or more														
Rated current (A)	Without power factor improving reactor	—	—	—	—	—	—	—	—	—	—	—	—	—	—	—
	With power factor improving reactor	300	350	400	500	600	700	800	900	1000	1100	1200	1350	1500	1800	2000

(2) Wiring of the power supply and motor

For wiring the input (R/L1, S/L2, T/L3) and output (U, V, W) terminals of the inverter, use the UL-listed copper wires (rated at 75°C(167°F)) and round crimping terminals. Crimp the crimping terminals with the crimping tool recommended by the terminal maker.

(3) Short circuit ratings

- 200V class
Suitable For Use in A Circuit Capable Of Delivering Not More Than 65kA rms Symmetrical Amperes, 264V Maximum.
- 400V class
01160 or less
Suitable For Use in A Circuit Capable Of Delivering Not More Than 65kA rms Symmetrical Amperes, 528V Maximum.
01800 or more
Suitable For Use in A Circuit Capable Of Delivering Not More Than 65kA rms Symmetrical Amperes, 550V Maximum.

(4) Motor overload protection

When using the electronic thermal relay function as motor overload protection, set the rated motor current to *Pr.9 Electronic thermal O/L relay*.

When connecting multiple motors to the inverter, install an external thermal relay individually.

Appendix 5 Instructions for Compliance with the European Directives

(1) EMC Directive

We have self-confirmed our inverters as products compliant to the EMC Directive (second environment of conforming standard EN61800-3) and place the CE mark on the inverters.

Note: First environment

Environment including residential buildings. Includes buildings directly connected without a transformer to the low voltage power supply network which supplies power to residential buildings.

Second environment

Environment including all buildings except buildings directly connected without a transformer to the low voltage power supply network which supplies power to residential buildings.

1) Notes

Set the EMC filter valid and install the inverter and perform wiring according to the following instructions.

- * The inverter is equipped with a built-in EMC filter. Set the EMC filter valid. (The EMC filter is invalid when shipped from the factory. (The FR-F720-00046 and 00077 are always valid.) For details, refer to page 24.)
- * Connect the inverter to an earthed power supply.
- * Install a motor and a control cable written in the EMC Installation Manual (BCN-A21041-204) according to the instruction.
- * The cable length between the inverter and the motor is 5 m (16.4 feet) maximum.
- * Confirm that the inverter complies with the EMC Directive as the industrial drives application for final installation.

(2) Low Voltage Directive

We have self-confirmed our inverters as products compliant to the Low Voltage Directive (Conforming standard EN 50178) and place the CE mark on the inverters.

1) Outline of instructions

- * Do not use a residual current operated protective device (RCD) as an electric shock protector without connecting the equipment to the earth. Connect the equipment to the earth securely.
- * Wire the earth terminal independently. (Do not connect two or more cables to one terminal.)
- * Use the cable sizes on page 14 under the following conditions.
 - Ambient temperature: 40°C (104°F) maximum
- If conditions are different from above, select appropriate wire according to EN60204 Appendix C TABLE 5.
- * Use a tinned (plating should not include zinc) crimping terminal to connect the ground cable. When tightening the screw, be careful not to damage the threads.
- For use as a product compliant with the Low Voltage Directive, use PVC cable whose size is indicated on page 14.
- * Use the moulded case circuit breaker and magnetic contactor which conform to the EN or IEC Standard.
- * Use the residual current operated protective device (RCD) of type B (breaker which can detect both AC and DC). If not, provide double or reinforced insulation between the inverter and other equipment, or put a transformer between the main power supply and inverter.
- * Use the inverter under the conditions of overvoltage category II (usable regardless of the ground condition of the power supply), overvoltage category III (usable with the earthed-neutral system power supply) and pollution degree 2 or lower specified in IEC664.
 - To use the inverter of 00770 or more (IP00) under the conditions of pollution degree 2, install it in the enclosure of IP 2X or higher.
 - To use the inverter under the conditions of pollution degree 3, install it in the enclosure of IP54 or higher.
 - To use the inverter of 00620 or less (IP20) outside of an enclosure in the environment of pollution degree 2, fix a fan cover with fan cover fixing screws enclosed.

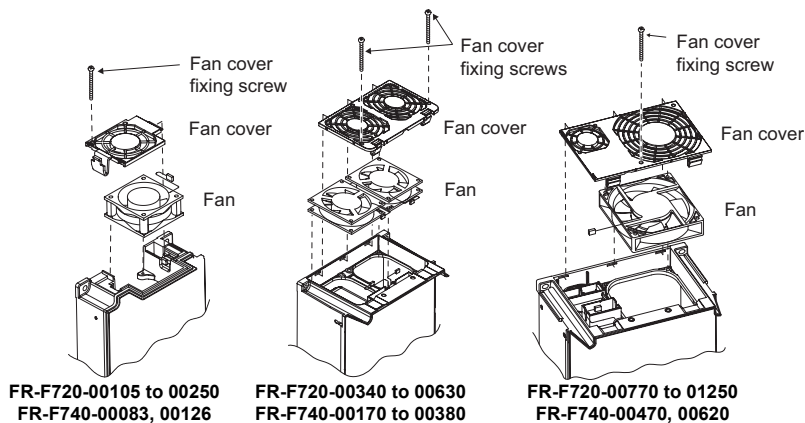

- * On the input and output of the inverter, use cables of the type and size set forth in EN60204 Appendix C.
- * The operating capacity of the relay outputs (terminal symbols A1, B1, C1, A2, B2, C2) should be 30VDC, 0.3A. (Relay outputs are basically isolated from the inverter internal circuit.)
- * Control circuit terminals on page 9 are safely isolated from the main circuit.
- * Environment

	During Operation	In Storage	During Transportation
Ambient temperature	LD: -10°C to +50°C (14°F to 122°F) SLD (initial setting): -10°C to +40°C (14°F to 104°F)	-20°C to +65°C (-4°F to +149°F)	-20°C to +65°C (-4°F to +149°F)
Ambient humidity	90% RH or less	90% RH or less	90% RH or less
Maximum altitude	1000m (3280.80feet)	1000m (3280.80feet)	10000m (32808feet)

Details are given in the technical information "Low Voltage Directive Conformance Guide" (BCN-A21041-203). Please contact your sales representative.

REVISIONS

*The manual number is given on the bottom left of the back cover.

Print Date	*Manual Number	Revision
Sep., 2004	IB(NA)-0600216ENG-A	First edition
Dec., 2004	IB(NA)-0600216ENG-B	<div style="border: 1px solid black; padding: 2px;">Additions</div> <ul style="list-style-type: none"> · FR-F720 - 03160 to 04750 - NA · FR-F740 - 04320 to 12120 - NA



For Maximum Safety

- Mitsubishi inverters are not designed or manufactured to be used in equipment or systems in situations that can affect or endanger human life.
- When considering this product for operation in special applications such as machinery or systems used in passenger transportation, medical, aerospace, atomic power, electric power, or submarine repeating applications, please contact your nearest Mitsubishi sales representative.
- Although this product was manufactured under conditions of strict quality control, you are strongly advised to install safety devices to prevent serious accidents when it is used in facilities where breakdowns of the product are likely to cause a serious accident.
- Please do not use this product for loads other than three-phase induction motors.